

# Service Manual

# Nakamichi Receiver 3



# CONTENTS

1.	General	1
2.	Removal Procedures	3
2. 1.	Top Cover	3
2. 2.	Bottom Cover	3
2. 3.	Front Panel Ass'y	3
2. 4.	Display & Control P.C.B. Ass'y	3
3.	Parts Location for Electrical Adjustment	4
4.	Electrical Adjustments	4
4. 1.	Power Amplifier Section	4
4. 2.	Tuner Section	5
5.	Mechanism Ass'y and Parts List	8
5. 1.	Synthesis	8
5. 2.	Chassis Ass'y (A01)	9
5. 3.	Heat Sink Ass'y. (B01)	10
5. 4.	Front Chassis Ass'y (B02)	10
6.	Mounting Diagrams and Parts List	11
6. 1.	AC Outlet P.C.B. Ass'y	11
6. 2.	Power Switch P.C.B. Ass'y	11
6. 3.	Speaker Switch P.C.B. Ass'y	11
6. 4.	Volume Indicator P.C.B. Ass'y	12
6. 5.	System Remote P.C.B. Ass'y	12
6. 6.	Volume P.C.B. Ass'y	12
6. 7.	Display & Control P.C.B. Ass'y	12
6. 8.	Main P.C.B. Ass'y	13
7.	Schematic Diagrams	15
7. 1.	IC Block Diagrams	15
7. 2.	Schematic Diagrams	17
	(1) Tuner Section	17
	(2) Amplifier Section	18
8.	Wiring Diagram	19
9.	Block Diagrams	20
9. 1.	Tuner & Display Control Section	20
9. 2.	Amplifier Section	21
10.	Specifications	22

## 1. GENERAL

### 1.1. Production No.

Production No.: D112

### 1.2. Destinations

USA, CAN, EP, UK, AUS, OTR, JPN

#### Abbreviation

USA — U.S.A.	AUS — Australia
CAN — Canada	OTR — Other
EP — Europe	JPN — Japan
UK — United Kingdom	

### 1.3. Parts Supply

#### (1) Unstocked Parts

Parts marked with “★” at the head of part No. are not stocked. So, it takes time to supply the parts after we receive your order.

#### (2) Unsupplied Parts

Parts without part Nos. (indicated as “—” in the parts list) are not supplied.

### 1.4. CAUTIONS/WARNINGS

#### (1) Product Safety Notice

Parts marked with the symbol  in the schematic diagram have critical characteristics.

Use ONLY replacement parts recommended by the manufacturer.

It is recommended that the unit be operated from a suitable DC supply or batteries during initial check-out procedures.

#### (2) Leakage Current Check/Resistance Check

Before returning the unit to the customer, make sure you make either (1) a leakage current check or (2) a line to chassis resistance check. If the leakage current exceeds 0.5 milliamp, or if the resistance from chassis to either side of the power cord is less than 240 k ohms, the unit is defective.

**WARNING — DO NOT** return the unit to the customer until the problem is located and corrected.

**(3) Lithium Battery Caution**

Use ONLY replacement parts recommended by the manufacturer. Replacement must be done only by qualified service personnel because of risk for explosion.

**VARNING**

Litiumbatteri. Explosionsfare ved felaktig hantering. Byte får endast ske av sakkunnig personal enligt servicedokumentationens anvisningar.

**ADVARSEL!**

Lithiumbatterier. Eksplosionsfare. Udskiftning må kun foretages af en sagkyndig og som beskrevet i servicemanualen. batterierne kun må udskiftes med batterier af samme fabrikat og type.

**(4) Resetting the MPU After Repair**

When the Receiver 3 does not work properly with the button operation after repair or after replacing the battery (the display shows abnormal indication), reset the Micro-processing Unit (MPU) U001 ( $\mu$ PD75208CW-A77) on the Display & Control P.C.B. Ass'y as follows:

1. With the power turned ON, ground the Reset Point on the Display & Control P.C.B. Ass'y.  
(See Fig. 6.7. Reset Point: Positive side of C004.)
2. Since the memory contents are cleared, reset them again.

**1.5. Package Ass'y**

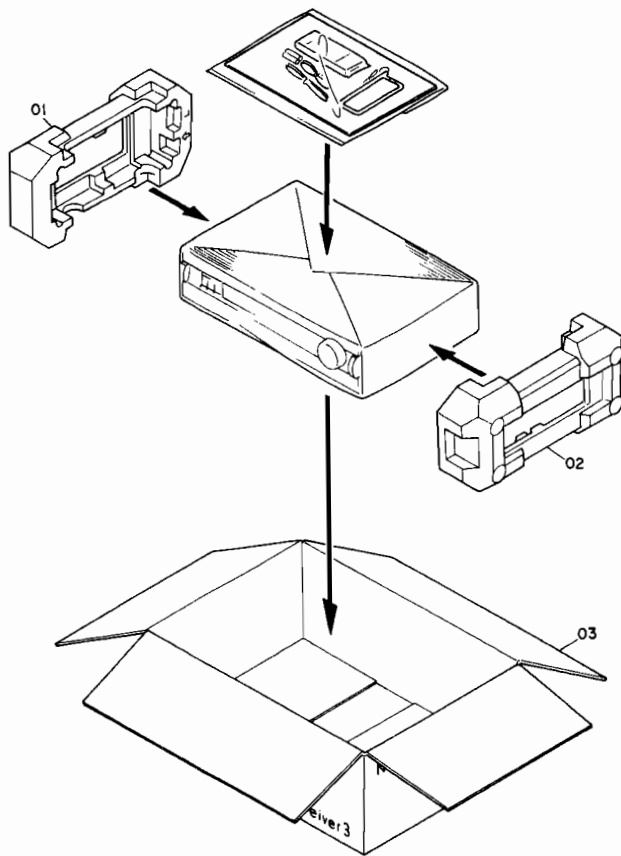

Fig. 1.1

**VOLTAGE SELECTOR**

Voltage selector is installed on the Rear Panel. The voltage selector can select 110, 120, 220, or 240V at customer's disposal.

**1.6. Accessory Ass'y**

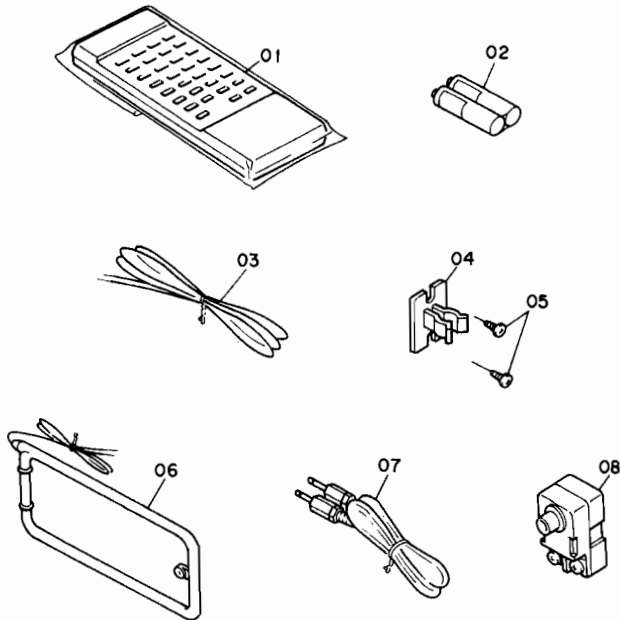

Fig. 1.2

Schematic Ref. No.	Part No.	Description	Qty
	—	<b>Package Ass'y</b>	
01	0F04484A	Packing L	1
02	0F04485A	Packing R	1
03	0F04486A	Carton Box	1
	CA81680A	Accessory Ass'y (USA, CAN, OTR)	1
	CA81811A	Accessory Ass'y (EP, UK, AUS)	1
	DA04445A	Accessory Ass'y (JPN)	1
01	CA81696A	Remote Control Unit	1
02	0B90341A	Battery AA Typex2	1
03	0C85437A	Feeder Antenna (USA, CAN, AUS, OTR)	1
	0B90320A	Feeder Antenna (EP, UK, JPN)	1
04	0B90319A	Loop Antenna Holder	1
05	0E03659A	3x12 $\phi$ Tapping (Black Chromate)	2
06	0C85374A	AM Loop Antenna	1
07	0C85415A	Pin-Pin Code	1
08	0B90194A	Antenna Adapter F (JPN)	1
	0B90208A	Antenna Adapter EP (EP, UK)	1
	0C85307A	Owner's Manual (English/German/French)	1
	0D06152A	Owner's Manual(Japanese)	1

## 2. REMOVAL PROCEDURES

### 2.1. Top Cover

Refer to Fig. 2.1.

- (1) Loosen screws F01 (5 pcs.) and remove F02 (Top Cover).

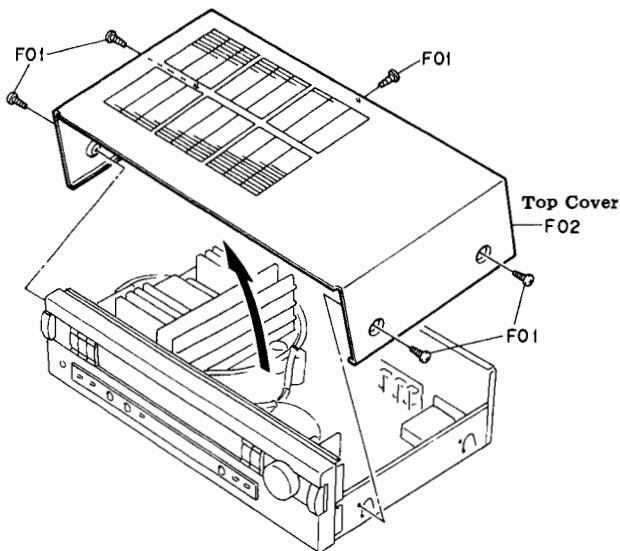

Fig. 2.1

### 2.2. Bottom Cover

Refer to Fig. 2.2.

- (1) Loosen screws F01 (5 pcs.) and remove F02 (Bottom Cover).

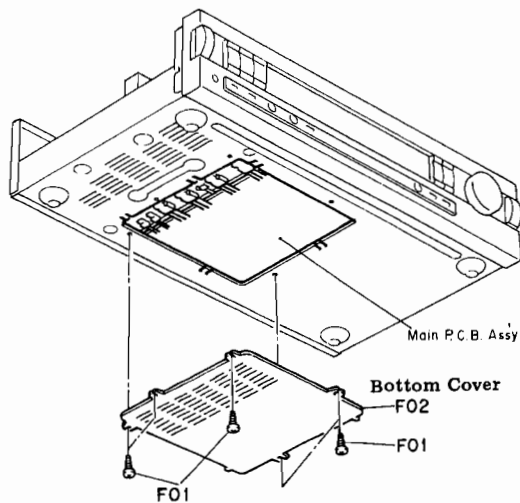

Fig. 2.2

### 2.3. Front Panel Ass'y

Refer to Fig. 2.3.

- (1) Remove the Top Cover referring to item 2.1.
- (2) Loosen screws F01 (3 pcs.) and F02 (3 pcs.), and remove F03 (Front Panel Ass'y).

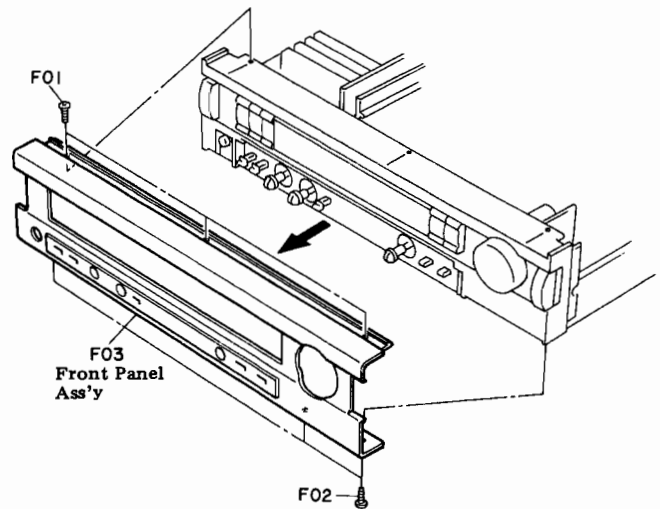

Fig. 2.3

### 2.4. Display & Control P.C.B. Ass'y

Refer to Figs. 2.4.1 and 2.4.2.

- (1) Remove the Front Panel Ass'y referring to item 2.3.
- (2) Disconnect all connectors, loosen a screw (F01), and remove F02 (System Remote P.C.B. Ass'y). See Fig. 2.4.1.
- (3) Remove F03 and loosen screws F04 (2 pcs.).
- (4) Remove F05 (Tone knob, 3 pcs.) and F06 (Nut & Washer, 3 sets), loosen screws F07 (2 pcs.) and F08 (4 pcs.), and disassemble F09 (Front Chassis Ass'y).
- (5) Loosen screws F10 (8 pcs.) and remove F11 (Display & Control P.C.B. Ass'y & System Remote P.C.B. Ass'y). See Fig. 2.4.2.

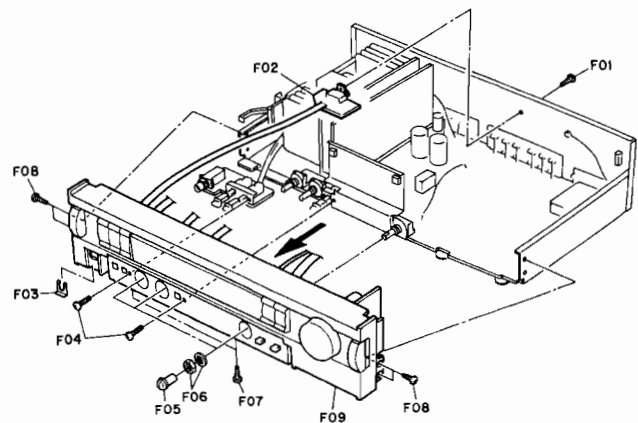

Fig. 2.4.1

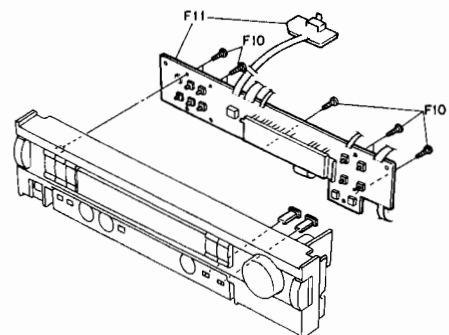

Fig. 2.4.2

### 3. PARTS LOCATION FOR ELECTRICAL ADJUSTMENT

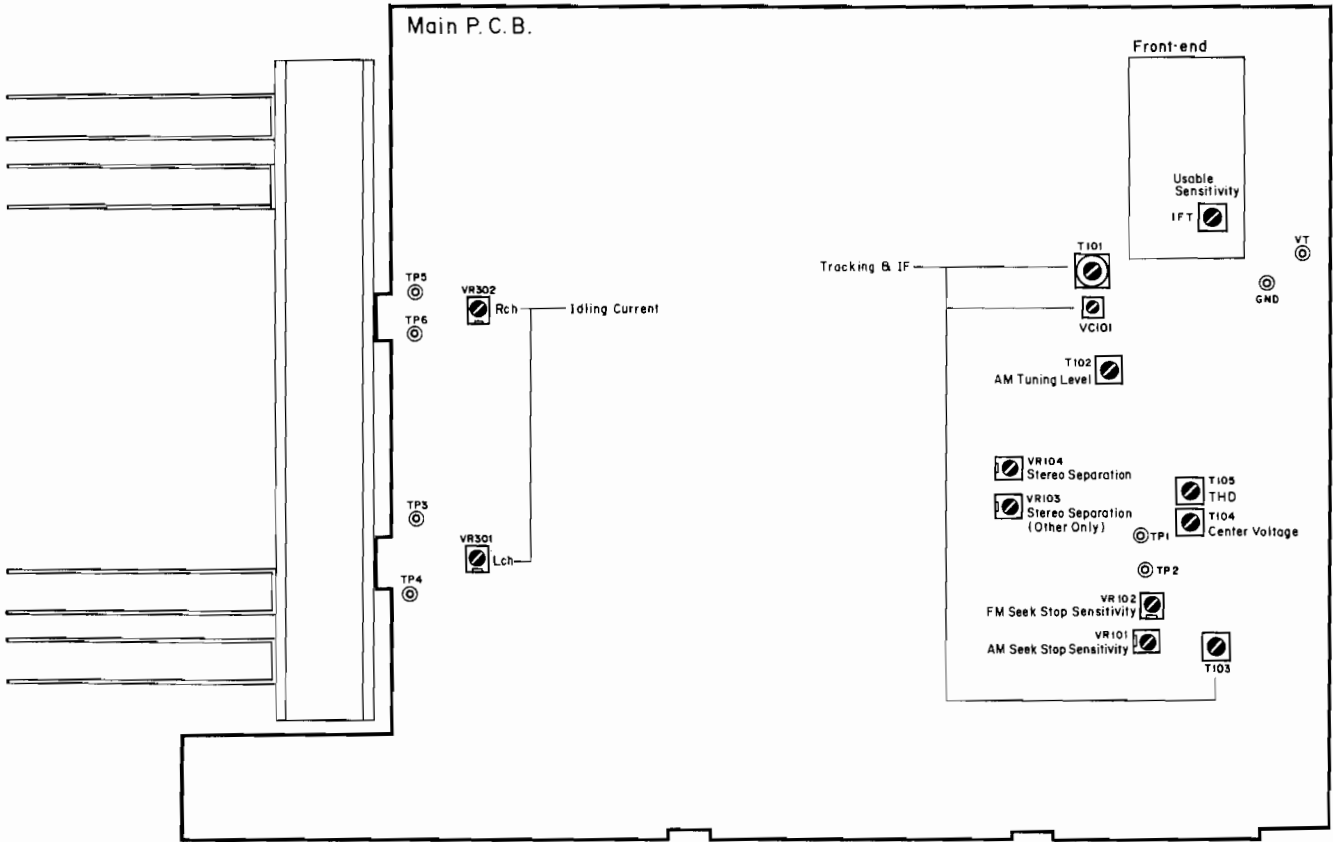

Fig. 3

### 4. ELECTRICAL ADJUSTMENTS

#### 4.1. Power Amplifier Section

STEP	ITEM	SIGNAL SOURCE	OUTPUT CONNECTION	MODE	ADJUSTMENT	REMARKS
1	Idling Current	None	DC Voltmeter between TP3,4 (L) and TP5,6 (R) on Main P.C.B.	Program Source Selector - CD Volume - Min. Speaker Selector - OFF	Main P.C.B. VR301 VR302	<ol style="list-style-type: none"> <li>1. Insert shorting plugs into the CD Player Input Jacks.</li> <li>2. Turn ON the power and allow 3 minutes before adjustment. (Top Cover must be installed in this period of time.)</li> <li>3. Adjust VR301 (VR302) to obtain 4 mV <math>\pm</math>1 mV on the DC voltmeter.</li> </ol>

#### 4.2. Tuner Section

Note: Adjustment should be made in a shielded room in principle.

##### (1) FM Tuner Section

STEP	ITEM	OUTPUT CONNECTION	MODE	ADJUSTMENT	REMARKS
1	Preliminary Step	See Fig. 4.1	Receiver 3 Program Source Selector - Tuner Band Selector - FM Tape Monitor - Source  Signal Generator Freq. - 98.1 MHz - 83 MHz (Japan) RF Level - 65 dBf Modulation - See REMARKS		1. Set the Receiver 3 as indicated in the MODE. 2. Adjustment and confirmation should be made after tuning in to the set carrier frequency of the Signal Generator.  Note: Contents of modulation 1. For U.S.A., Canada, Other (Wide) & Japan o Stereo Audio: 1 kHz, 91% Pilot: 19 kHz, 9% o Mono Audio: 1 kHz, 100% 2. For Australia, Europe & Other (Narrow) o Stereo Audio: 1 kHz, 51% Pilot: 19 kHz, 9% o Mono Audio: 1 kHz, 60%
2	Usable Sensitivity Adjustment	Distortion Meter to Tape Record Output Jacks	Receiver 3 Same as above  Signal Generator Freq. - 98.1 MHz - 83 MHz (Japan) RF Level - 13.5 dBf Modulation - Mono	Main P.C.B. Front-end IFT	1. Set the Receiver 3 to Manual mode by pressing the Tuning Mode button. 2. Adjust the IFT to obtain minimum distortion (total harmonic distortion (THD): 3% or less). 3. Set the frequency of the Signal Generator to 90.1 MHz/106.1 MHz and check that the THD is 3% or less.
3	Center Voltage and THD Adjustment	DC Voltmeter between TP1 & TP2 on Main P.C.B. and Distortion Meter to Tape Record Output Jacks	Receiver 3 Same as above  Signal Generator Freq. - 98.1 MHz - 83 MHz (Japan) RF Level - 65 dBf Modulation - Mono	Main P.C.B. T104 T105	1. Set the Receiver 3 to Manual mode. 2. Adjust T104 so that the reading on the DC voltmeter is 0 V $\pm$ 20 mV. 3. Adjust T105 to obtain minimum distortion (THD: 0.1% or less). Repeat 2 and 3, if necessary.
4	Seek Stop Sensitivity Adjustment	Oscilloscope to Tape Record Output Jacks	Receiver 3 Same as above  Signal Generator Freq. - 98.1 MHz - 83 MHz (Japan) RF Level - 30 dBf Modulation - Stereo	Main P.C.B. VR102	1. Set the Receiver 3 to Auto mode. 2. Rotate VR102 fully counterclockwise. Then, return it clockwise gradually until a waveform appears on the oscilloscope. 3. Decrease the RF level of the Signal Generator until the waveform on the oscilloscope disappears. Then increase the RF level gradually until a waveform appears again. At this point, check that the RF level of the Signal Generator is 30 dBf $\pm$ 6 dB.

STEP	ITEM	OUTPUT CONNECTION	MODE	ADJUSTMENT	REMARKS
5	Stereo Separation Adjustment	AC Voltmeter to Tape Record Output Jacks	Receiver 3 Same as above  Signal Generator Freq. - 98.1 MHz - 83 MHz (Japan) RF Level - 65 dBf Modulation - L or R only	Main P.C.B. VR104  VR103 (Other only)	For U.S.A., Canada, Europe, Australia & Japan versions: 1. Set the Receiver 3 to Auto mode. 2. Apply modulation to only L channel. 3. Adjust VR104 to obtain minimum reading on the AC voltmeter at the R channel output jack. 4. Apply modulation to only R channel. 5. Check that the reading on the AC voltmeter at the L channel output jack is within $\pm 1$ dB with respect to the reading in 3. If not, repeat 2 through 4.  For Other version: 1. Set the switches on the rear panel as follows: Freq. Step FM/AM - 100 kHz/10 kHz IF Band - Wide 2. Apply the same procedures as above. 3. Set the switches as follows: Freq. step FM/AM - 50 kHz/9 kHz IF Band - Narrow 4. Apply the same procedures as mentioned above. However, adjust VR103 instead of VR104.

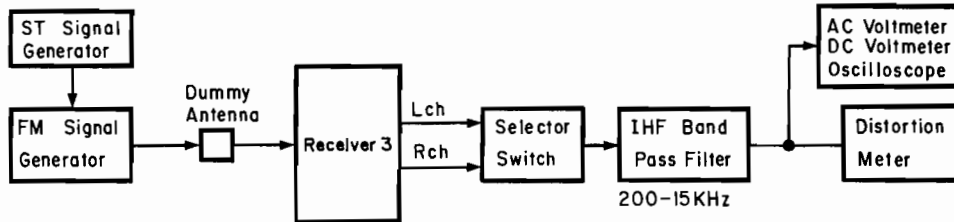

Fig. 4.1 FM Measuring Connecting Diagram

(2) AM Tuner Section

Note: Frequencies for Australia, Europe and Other (Narrow) are indicated in parentheses.

STEP	ITEM	OUTPUT CONNECTION	MODE	ADJUSTMENT	REMARKS
1	Tuning Level Adjustment	DC Voltmeter between TP (VT) and TP (GND) on Main P.C.B.	Receiver 3 Program Source Selector - Tuner Band Selector - AM Tape Monitor - Source  Signal Generator Freq. - 520 (522) kHz/ 1710 (1611) kHz Modulation - 400 Hz 30%	Main P.C.B. T102	<ol style="list-style-type: none"> <li>1. Set the frequency of the Signal Generator to 520 kHz (522 kHz) and make tuning.</li> <li>2. Adjust T102 to obtain 1.2 V<math>\pm</math>0.02 V on the DC voltmeter.</li> <li>3. Change the frequency to 1710 kHz (1611 kHz) and make tuning. Check whether the DC voltmeter reads 7.5 V to 8 V.</li> </ol>
2	Tracking and IF Adjustment	AC Voltmeter to Tape Record Output Jacks	Receiver 3 Same as above  Signal Generator Freq. - 600 (603) kHz/ 1400 (1404) kHz RF Level - 82 dB $\mu$ Modulation - 400 Hz 30%	Main P.C.B. T101 T103 VC101	<ol style="list-style-type: none"> <li>1. Set the measurement instruments as shown in Fig. 4.2. Set the distance between the AM Loop Antenna of the Receiver 3 and a test loop to 60 cm. To obtain 56 dB<math>\mu</math>/m at the AM Loop Antenna, set the RF level output of the AM Signal Generator to 82 dB<math>\mu</math> as loss is 26 dB in this setting.</li> <li>2. Set the frequency of the Signal Generator to 600 kHz (603 kHz) and make tuning.</li> <li>3. Adjust T101 to obtain maximum reading on the AC voltmeter.</li> <li>4. Adjust T103 to obtain maximum reading on the AC voltmeter.</li> <li>5. Set the frequency to 1400 kHz (1404 kHz) and make tuning.</li> <li>6. Adjust VC101 to obtain maximum reading on the AC voltmeter.</li> <li>7. Repeat 2 through 7 once.</li> </ol>
3	Seek Stop Sensitivity Adjustment	Oscilloscope to Tape Record Output Jacks	Receiver 3 Same as above  Signal Generator Freq. - 1000 kHz - 999 kHz (Japan) RF Level - 76 dB $\mu$ Modulation - 400 Hz 30%	Main P.C.B. VR101	<ol style="list-style-type: none"> <li>1. Set the Receiver 3 to Auto mode.</li> <li>2. Rotate VR101 fully counterclockwise. Then, return it clockwise gradually until a waveform appears on the oscilloscope.</li> <li>3. Decrease the RF level of the Signal Generator until the waveform on the oscilloscope disappears. Then increase the RF level gradually until a waveform appears again. At this point, check that the RF level of the Signal Generator is 50 dBf <math>\pm</math>8 dB<math>\mu</math>.</li> </ol>

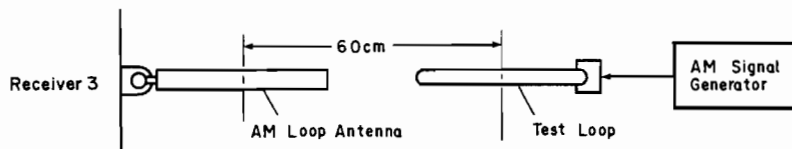

Fig. 4.2



## 5. MECHANISM ASS'Y AND PARTS LIST

### 5.1. Synthesis

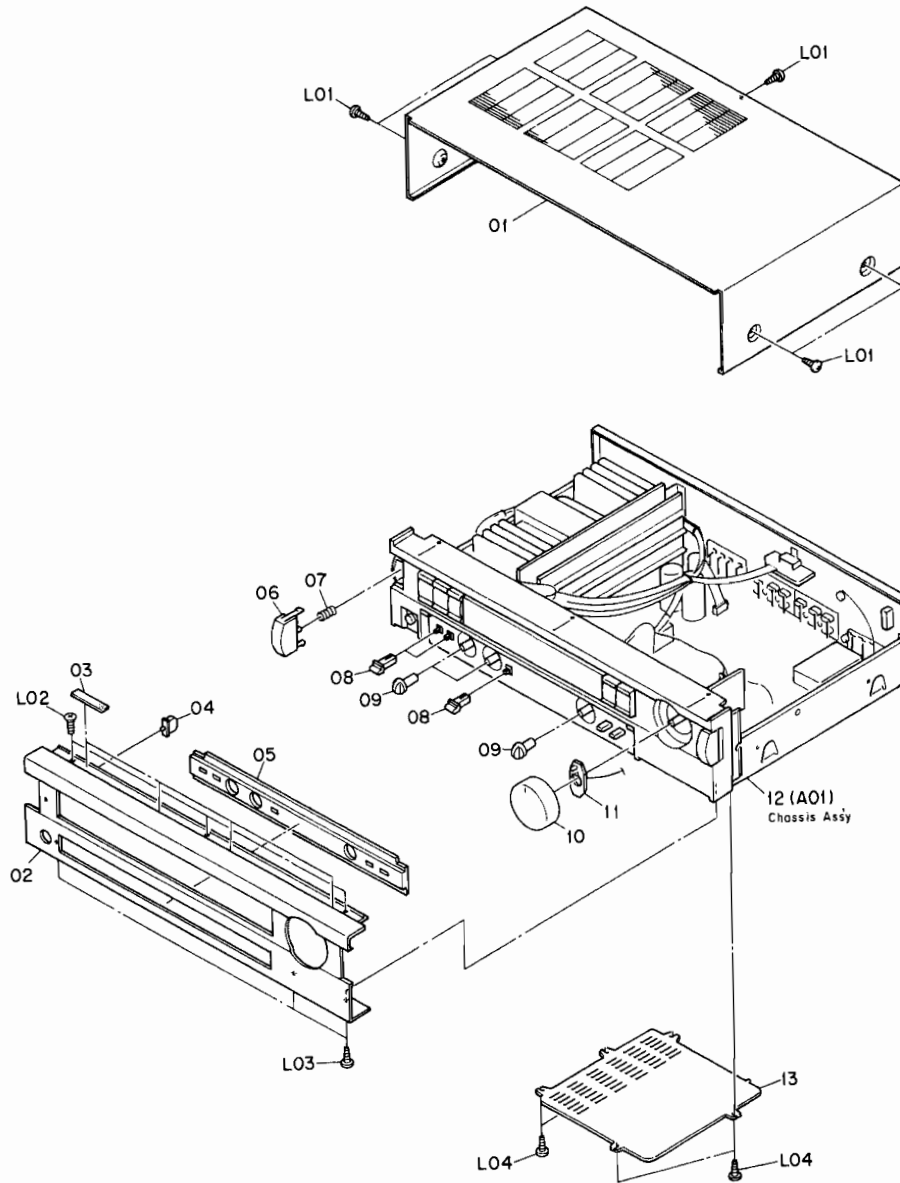

Fig. 5.1

\*: Unstocked parts.

Schematic Ref. No.	Part No.	Description	Qty	Schematic Ref. No.	Part No.	Description	Qty
<b>5.1. Synthesis</b>				L01	0E03433A	BT3x6 ⊕ Binding Projected (Black Chromate)	
				L02	0E03495A	BT3x10 ⊕ Countersunk (Black Chromate)	
				L03	0E00948A	BT3x10 ⊕ Binding (Black Chromate)	
				L04	0E00857A	BT3x6 ⊕ Binding	
		<b>Synthesis</b>					
01	0H05315A	Top Cover	1				
02	0C85340A	Front Panel	1				
03	0J05407A	Top Cover Sheet R	4				
04	0C85342A	LED Lens	1				
05	0C85341A	Tone Panel	1				
06	0C85345A	Power Switch Knob	1				
07	0C85347A	Power Switch Spring	1				
08	0C85344A	Push Switch Knob	3				
09	0C85343A	Tone Knob	3				
10	CA81683A	Volume Knob Ass'y	1				
11	* CA81685A	Volume Indicator P.C.B. Ass'y (USA, CAN, EP, UK, AUS, OTR)	1				
	* BA08114A	Volume Indicator P.C.B. Ass'y (JPN)	1				
12	—	Chassis Ass'y	1				
13	0C85346A	Bottom Cover	1				

5.2. Chassis Ass'y (A01)

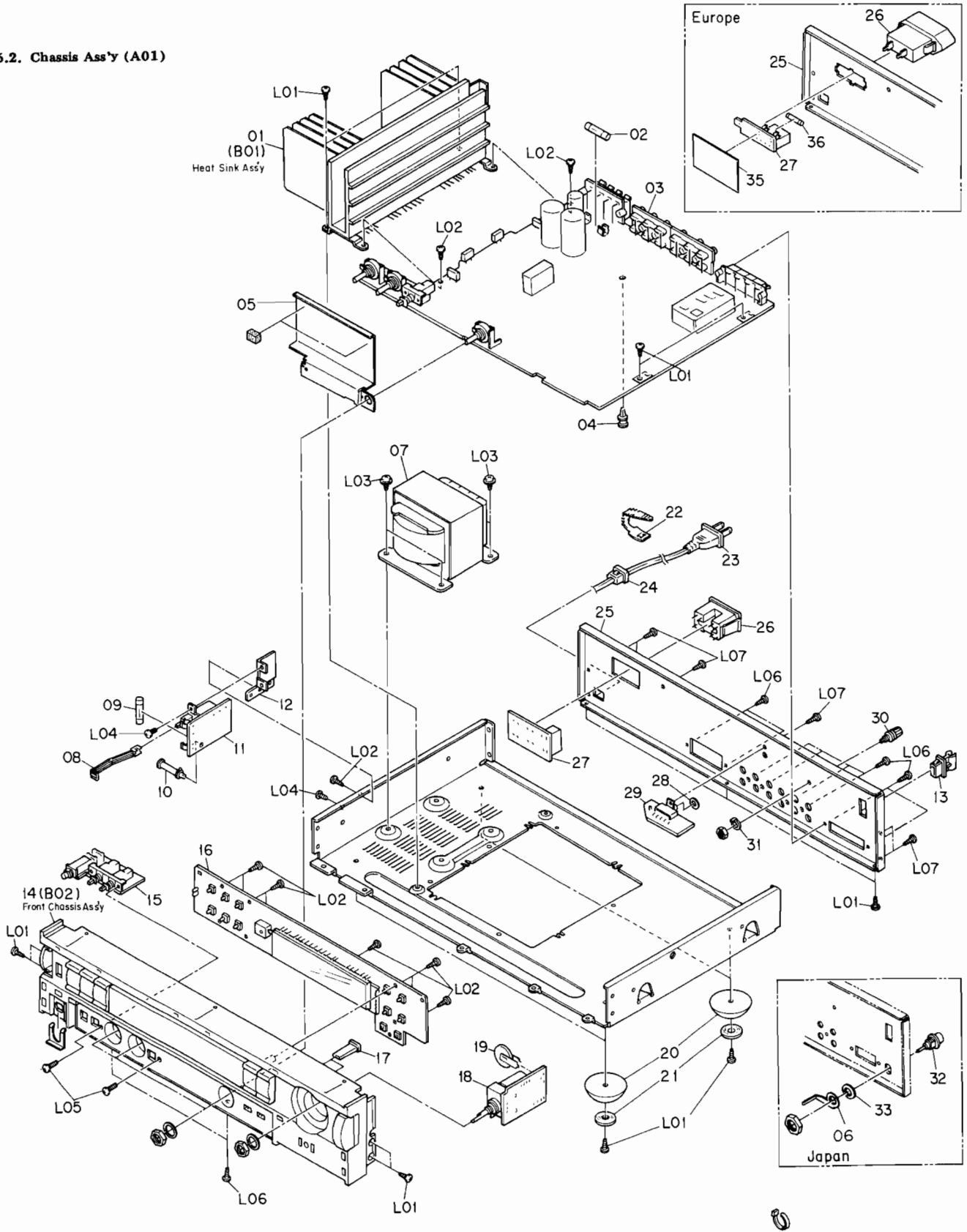

Fig. 5.2

Schematic Ref. No.	Part No.	Description	Qty
<b>5.2. Chassis Ass'y (A01)</b>			
A01	—	Chassis Ass'y	1
01	—	Heat Sink Ass'y	1
02	OB90329A	Fuse T1A/125V [F402] (USA, CAN, OTR)	1
	OB90289A	Fuse T1A/250V [F402] (EP, UK, AUS)	1
	OB90520A	Fuse 1A/250V [F402] (JPN)	1
03	* CA81689A	Main P.C.B. Ass'y (USA, CAN)	1
	* CA81677A	Main P.C.B. Ass'y (EP)	1
	* CA81812A	Main P.C.B. Ass'y (UK)	1
	* CA81813A	Main P.C.B. Ass'y (AUS)	1
	* CA81814A	Main P.C.B. Ass'y (OTR)	1
	* BA08110A	Main P.C.B. Ass'y (JPN)	1
04	OC85351A	P.C.B. Support 6mm	1
05	OC85359A	Shield Plate T	1
06	OC85442A	Lug Terminal (EP, UK, JPN)	1
07	OC85362A	Power Transformer EI-76(T) (USA, CAN)	1
	OC85447A	Power Transformer (EP, UK, AUS)	1
	OC85450A	Power Transformer (OTR)	1
	OC85444A	Power Transformer (JPN)	1
08	OC85357A	Power Switch Joint	1
09	OB90330A	Fuse T3A/250V [F401] (USA, CAN, OTR)	1
	OB90289A	Fuse T1A/250V [F401] (EP)	1
	OB90373A	Fuse 3A/250V [F401] (JPN)	1
10	OC85361A	P.C.B. Support 25mm	1
11	* CA81687A	Power Switch P.C.B. Ass'y (USA, CAN, OTR)	1
	* CA81678A	Power Switch P.C.B. Ass'y (EP)	1
	* CA81815A	Power Switch P.C.B. Ass'y (UK, AUS)	1
	* BA08116A	Power Switch P.C.B. Ass'y (JPN)	1
12	OC85360A	Power Switch Bracket	1
13	OB90316A	Antenna Holder	1
14	—	Front Chassis Ass'y	1
15	* CA81686A	Speaker Switch P.C.B. Ass'y (USA, CAN, EP, UK, AUS, OTR)	1
	* BA08111A	Speaker Switch P.C.B. Ass'y (JPN)	1
16	* CA81691A	Display & Control P.C.B. Ass'y (USA, CAN)	1
	* CA81703A	Display & Control P.C.B. Ass'y (EP, UK)	1
	* CA81818A	Display & Control P.C.B. Ass'y (AUS)	1
	* CA81819A	Display & Control P.C.B. Ass'y (OTR)	1
	* BA08113A	Display & Control P.C.B. Ass'y (JPN)	1
17	OC85354A	Tact Switch Knob	2
18	* CA81690A	Volume P.C.B. Ass'y (USA, CAN, EP, UK, AUS, OTR)	1
	* BA08112A	Volume P.C.B. Ass'y (JPN)	1
19	OB90200B	Lithium Battrey CR2430-FT4-2	1
20	OC85356A	Leg	4
21	OC85358A	Leg Felt Sheet	4
22	OJ05665A	Free-up Belt	1
23	OB80199A	AC Power Cord (USA, CAN)	1
	OC85878A	AC Power Cord (UK)	1
	OB80148A	AC Power Cord (AUS)	1
	OC85877A	AC Power Cord (OTR)	1
	OB90274A	AC Power Cord (JPN)	1
24	OB90280A	Cord Bushing	1
25	OC85353A	Rear Panel (USA, CAN)	1
	OC85509A	Rear Panel (EP)	1
	OC85887A	Rear Panel (UK)	1
	OC85888A	Rear Panel (AUS)	1
	OC85889A	Rear Panel (OTR)	1
	OH05968A	Rear Panel (JPN)	1
26	OB81928A	AC Outlet (USA, CAN, OTR)	1
	OB81987A	AC Outlet (EP)	1
	OC85876A	AC Outlet (UK)	1
	OB81988A	AC Outlet (AUS)	1
	OB81986A	AC Outlet (JPN)	1
27	* CA81688A	AC Outlet P.C.B. Ass'y (USA, CAN)	1
	* CA81679A	AC Outlet P.C.B. Ass'y (EP)	1
	* CA81816A	AC Outlet P.C.B. Ass'y (OTR)	1
	* BA08117A	AC Outlet P.C.B. Ass'y (JPN)	1
28	OB90400A	Fiber Washer 6mm	1
29	* CA81692A	System Remote P.C.B. Ass'y (USA, CAN, EP, UK, AUS, OTR)	1
	* BA08115A	System Remote P.C.B. Ass'y (JPN)	1
30	JA04383A	Ground Terminal Ass'y (USA, CAN, EP, OTR, JPN)	1
31	OJ05703A	Lug Terminal	1
32	OB81979A	Antenna Terminal (EP, UK)	1
	OC09584A	Antenna Terminal F (JPN)	1
33	OC85445A	Ground Washer (EP, UK, JPN)	1
34	OC85539A	Insulator A (EP)	1
35	OC85563A	Insulator B (EP)	1
36	OB90350A	Fuse T2.5A/250V [F403] (EP)	1
L01	OE00857A	BT3x6 @ Binding	1
L02	OE00868A	BT3x8 @ Binding	1
L03	OC85421A	ST4x6 @ Binding Washer-Faced	1
L04	OE00896A	M3x6 @ Binding	1
L05	OE03660A	M3x14 @ Binding	1
L06	OE00948A	BT3x10 @ Binding (Black Chromate)	1
L07	OE000860A	BT3x6 @ Binding (Black Chromate)	1
	OE00985A	M3x6 @ Binding (OTR) (Black Chromate)	1
	OE03072A	M2.6x6 @ Binding (OTR) (Black Chromate)	1
—	OB90289A	Fuse T1A/250V [F401] (UK, AUS)	1
—	OB90350A	Fuse T2.5A/250V [F403] (UK, AUS)	1
—	OC85600A	Voltage Selector (OTR)	1
—	CA81817A	IFS/DU Switch P.C.B. Ass'y (OTR)	1

### 5.3. Heat Sink Ass'y (B01)

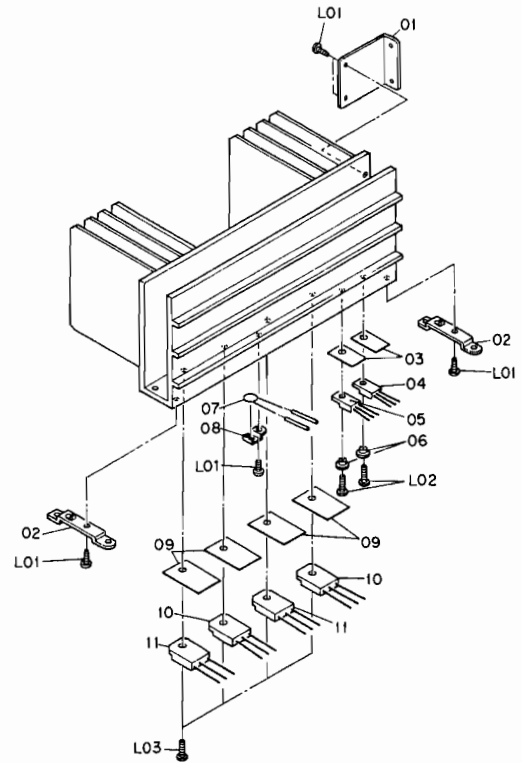

Fig. 5.3

### 5.4. Front Chassis Ass'y (B02)

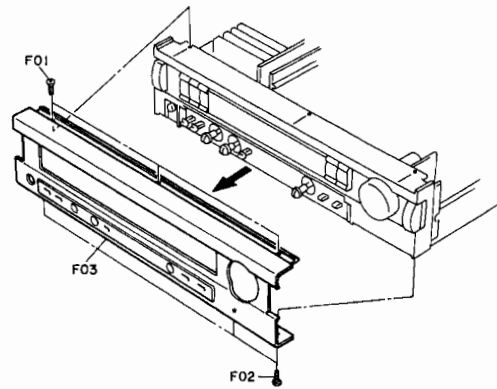

Fig. 5.4

Schematic Ref. No.	Part No.	Description	Qty
<b>5.3. Heat Sink Ass'y (B01)</b>			
B01	—	Heat Sink Ass'y	1
01	OC85393A	Heat Sink Bracket A	1
02	OC85394A	Heat Sink Bracket B	2
03	OJ05672A	Insulator TO-220 (U401,402)	2
04	OB11011A	IC μPC7812H [U401]	1
05	OB11010A	IC μPC7805H [U402]	1
06	OB90368A	Transistor Bush for U401,402	2
07	OB19607A	Thermistor 50KD-5 [TH301]	1
08	OJ05615A	TH Holder	1
09	OJ05671A	Insulator TO-3P for Q310L,R/Q311L,R	4
10	OB10245A	TR 2SC3181N [Q310L,R]	2
11	OB10244A	TR 2SA1264N [Q311L,R]	2
L01	OE00868A	BT3x8 @ Binding	1
L02	OE00766A	M3x8 @ Binding	1
L03	OE00986A	M3x10 @ Binding	1
<b>5.4. Front Chassis Ass'y (B02)</b>			
B02	—	Front Chassis Ass'y	1
01	OC85390A	Control Knob	5
02	OC85389A	Dummy Cap	1

## 6. MOUNTING DIAGRAMS AND PARTS LIST

Notes: 1. Mounting diagram shows a dip side view of the printed circuit board.

2. Diode is 1SS53, 1S1555, or 1SS176 unless otherwise specified.

3. Following transistors are interchangeable with each other.

a. 2SA733, 2SA608SP, 2SA1048, 2SA1175

b. 2SC945, 2SC536SP, 2SC2458, 2SC2785

4. Abbreviation for part name:

TR — Transistor, SiD — Silicon Diode, ZD — Zener Diode, Varicap — Variable Capacitance Diode

RK — Carbon Resistor, RM — Metal Film Resistor, RF — Fail Safe Type Resistor, RC — Cement Resistor

CE — Electrolytic Capacitor, CML — Mylar Capacitor, CC — Ceramic Capacitor, CPP — PP Capacitor,

CMM — Metalized Mylar Capacitor, CSP — Polystyrene Capacitor, C — Mica Capacitor

CT — Tantalum Capacitor

### 6.1. AC Outlet P.C.B. Ass'y

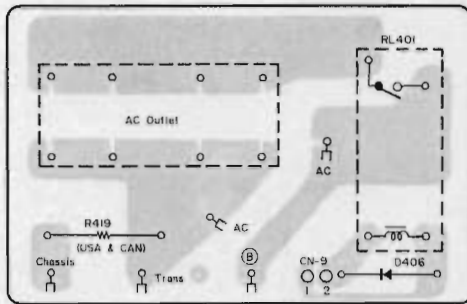

Fig. 6.1.1 USA, CAN, OTR, JPN

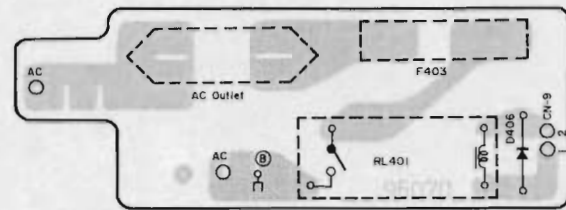

Fig. 6.1.2 EP

### 6.2. Power Switch P.C.B. Ass'y

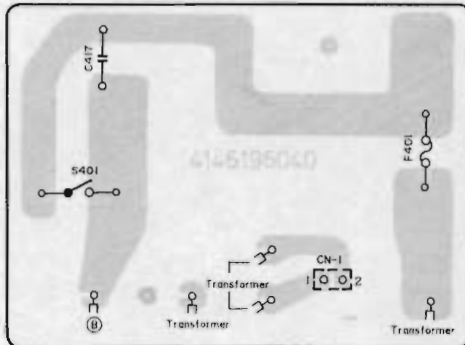

Fig. 6.2 USA, CAN, EP, OTR, JPN

### 6.3. Speaker Switch P.C.B. Ass'y

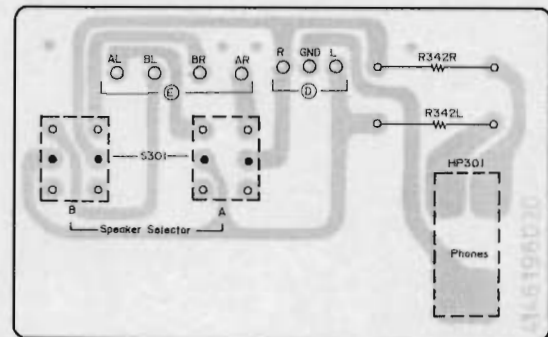

Fig. 6.3

\*: Unstocked parts.

Schematic Ref. No.	Part No.	Description	Schematic Ref. No.	Part No.	Description	Schematic Ref. No.	Part No.	Description
6.1. AC Outlet P.C.B. Ass'y			6.2. Power Switch P.C.B. Ass'y			* CA81815A Power Switch P.C.B. Ass'y (UK, AUS)		
	* CA81688A	AC Outlet P.C.B. Ass'y (USA, CAN)		* CA81687A	Power Switch P.C.B. Ass'y (USA, CAN, OTR)	D406 C417 RL401 S401 CN1 CN9	0C85891A	Power Switch P.C.B. SiD 1N4002L
	* CA81816A	AC Outlet P.C.B. (OTR)		* CA81678A	Power Switch P.C.B. Ass'y (EP)		0B12586A	CC 4700P AC400V
	* BA08117A	AC Outlet P.C.B. Ass'y (JPN)		* BA08116A	Power Switch P.C.B. Ass'y (JPN)		0B41825A	Relay VS-12MB-VD3
D406	0C85385A	AC Outlet P.C.B. SiD 1N4002	C417	0C85384A	Power Switch P.C.B. CC 4700P AC400V (USA, CAN, EP, OTR)		0B90334A	Power Switch
R419	0B12586A	RK 3.3M 1/2W J (USA, CAN)		0B41826A	CC 4700P 250V (JPN)		0B71011A	2P-S Post
RL401	0B05919A	Relay VS-12MBU	S401	0B71011A	Power Switch (USA, CAN, EP, OTR)		0B81666A	2P Connector Ass'y
CN9	0B90334A	2P Connector Ass'y	CN1	0B71013A	Power Switch (JPN)		0B83490A	450mm Fuse Holder (4)
	0B83490A			0B81666A	2P S-Post			
	* CA81679A	AC Outlet P.C.B. Ass'y (EP)		0B81930A	Fuse Holder SN-5051 (USA, CAN, OTR, JPN) (2)			
D406	0C85448A	AC Outlet P.C.B. SiD 1N4002		0B81848A	Fuse Holder (EP) (2)			
RL401	0B12586A	RK 3.3M 1/2W J (USA, CAN)						
CN9	0B90334A	Relay VS-12MBU						
	0B83490A	2P Connector Ass'y						
	0B81848A	Fuse Holder (2)						

6.4. Volume Indicator P.C.B. Ass'y



Fig. 6.4

6.5. System Remote P.C.B. Ass'y

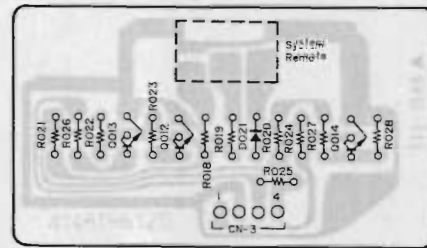

Fig. 6.5

6.6. Volume P.C.B. Ass'y

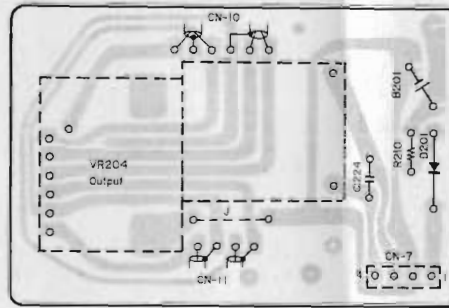

Fig. 6.6

6.7. Display & Control P.C.B. Ass'y

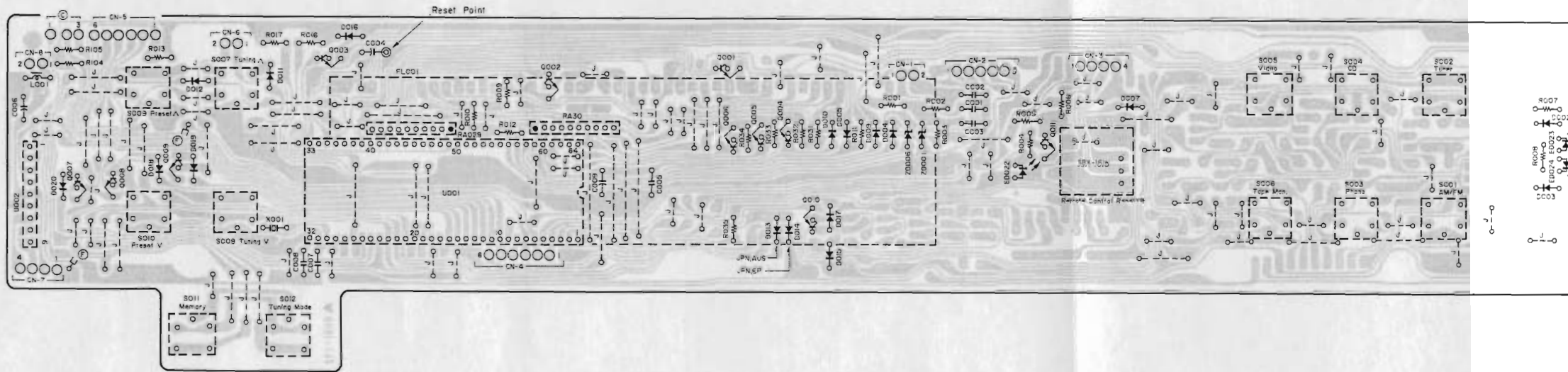
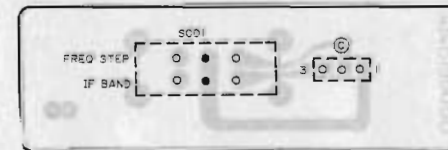

Fig. 6.7

\*: Unstocked parts.

Schematic Ref. No.	Part No.	Description	Schematic Ref. No.	Part No.	Description	Schematic Ref. No.	Part No.	Description
6.3. Speaker Switch P.C.B. Ass'y			6.5. System Remote P.C.B. Ass'y			6.6. Volume P.C.B. Ass'y		
	* CA81686A	Speaker Switch P.C.B. Ass'y (USA, CAN, EP, UK, AUS, OTR)		* CA81692A	System Remote P.C.B. Ass'y (USA, CAN, EP, UK, AUS, OTR)		* CA81690A	Volume P.C.B. Ass'y (USA, CAN, EP, UK, AUS, OTR)
	* BA08111A	Speaker Switch P.C.B. Ass'y (JPN)		* BA08115A	System Remote P.C.B. Ass'y (JPN)		* BA08112A	Volume P.C.B. Ass'y (JPN)
R342L,R HP301 S301	OC85380A OB24184A OB81757A OC85383A	Speaker Switch P.C.B. RF 330 1W J Headphone Jack Push Switch		OC85403A	System Remote P.C.B.	D201 VR204 R210 C224 CN7 CN10 CN11	OC85376A OB12584A OC85379A OB09665A OB09291A OB81761A OC85377A OC85378A	Volume P.C.B. SID IN4148 VR 50KBx2 RK 330 1/6W J CC 0.022µ 50V Z 4P-T Post 5P Connector Ass'y 4P Connector Ass'y
6.4. Volume Indicator P.C.B. Ass'y				Q012,013 Q014 D021 R018 R019 R020 R021 R022,023 R024,025 R026 R027,028 CN3	OB06100A TR 2SC945 OB06100A TR 2SC945 OB06398A SID 1SS176 OB09677A RK 1K 1/6W J OB09637A RK 22 1/6W J OB09701A RK 10K 1/6W J OB09709A RK 22K 1/6W J OB09701A RK 10K 1/6W J OB09701A RK 10K 1/6W J OB09717A RK 47K 1/6W J OB09701A RK 10K 1/6W J OC85402A Ribbon Wire 4P 340mm OB81952A ST Mini Jack (1) OC85404A Mini Jack Bracket (1)			
ED202	* CA81685A * BA08114A OC85386A OC85387A OB12710A	Volume Indicator P.C.B. Ass'y (USA, CAN, EP, UK, AUS, OTR) Volume Indicator P.C.B. Ass'y (JPN) Volume Indicator P.C.B. LED LTL-4231 Green (USA, CAN, EP, UK, AUS, OTR) LED SLR-34MW3F (JPN)						
CN12	OC85405A	2P Connector Ass'y						

IFS/DU Switch P.C.B. Ass'y (OTR)



\*: Unstocked parts.

Schematic Ref. No.	Part No.	Description
	* CA81817A	IFS/DU Switch P.C.B. Ass'y (OTR)
S001	OC85449A OB70137A OB81667A	IFS/DU Switch P.C.B. Slide Switch 3P-S Post (1)

\*: Unstocked parts.

Schematic Ref. No.	Part No.	Description
6.7. Display & Control P.C.B. Ass'y		
	* CA81691A	Display & Control P.C.B. Ass'y (USA, CAN)
	* CA81703A	Display & Control P.C.B. Ass'y (EP, UK)
	* CA81818A	Display & Control P.C.B. Ass'y (AUS)
	* CA81819A	Display & Control P.C.B. Ass'y (OTR)
	* BA08113A	Display & Control P.C.B. Ass'y (JPN)
	OC85396A	Display & Control P.C.B.
U001	OB11872A	IC
U002	OB11530A	LPD75208CW-A77 IC BA6208
Q001,002	OB10328A	TR DTC114TF
Q003,004	OB10328A	TR DTC114TF
Q005,006	OB10328A	TR DTC114TF
Q007,008	OB10062A	TR DTC144ES
Q009	OB10062A	TR DTC144ES
Q010	OB10327A	TR DTA144TF
Q011	OB06100A	TR 2SC945
ZD001	OB12159A	ZD 7.5V B2
ZD006	OB06232A	ZD 9.1V B2
ED022,023	OC85387A	LED LTL-4231 GRN (USA, CAN, EP, UK, AUS, OTR)
	OB12710A	LED SLR-34MW3F (JPN)
ED024	OC85439A	LED SLR-34PC3F AMBER (USA, CAN, EP, UK, AUS, OTR)
	OC85387A	LED SLR-34DC3F (JPN)
D002,003	OB06398A	SID 1SS176
D004,005	OB06398A	SID 1SS176
D007	OB06398A	SID 1SS176
D009,010	OB06398A	SID 1SS176
D011,012	OB06398A	SID 1SS176
D013	OB06398A	SID 1SS176
D014	OB06398A	SID 1SS176 (AUS, JPN)
D015,016	OB06398A	SID 1SS176 (EP, UK, JPN)
D017,018	OB06398A	SID 1SS176
D019,020	OB06398A	SID 1SS176
X001	OB92031A	Ceramic Resonator 4.19MHz
L001	OB51277A	Motor Choke Coil 1mH K
RA029,030	OC85397A	R Array 100Kx9
R001,002	OB09661A	RK 220 1/6W J
R003	OB09701A	RK 10K 1/6W J
R004	OB09661A	RK 220 1/6W J
R005,006	OB09701A	RK 10K 1/6W J
R007,008	OB09661A	RK 220 1/6W J
R009,010	OB09725A	RK 100K 1/6W J
R011	OB09709A	RK 22K 1/6W J
R012	OB09721A	RK 68K 1/6W J
R013	OB09701A	RK 10K 1/6W J
R014,015	OB09705A	RK 10K 1/6W J
R016,017	OB09725A	RK 100K 1/6W J
R031,032	OB09725A	RK 100K 1/6W J
R033,034	OB09725A	RK 100K 1/6W J
R035	OB09711A	RK 27K 1/6W J
C001,002	OB09292A	CC 0.1µ 50V Z
C003	OB09291A	CC 0.022µ 50V Z
C004	OB01405A	CE 1µ 50V
C005	OB09291A	CC 0.022µ 50V Z
C006	OB01403A	CE 47µ 16V
C007,008	OB41740A	CC 33P 50V J
C009	OB40807A	CE 1µ 50V
S001,002	OC85398A	Tact Switch
S003,004	OC85398A	Tact Switch
S005,006	OC85398A	Tact Switch
S007,008	OC85398A	Tact Switch
S009,010	OC85398A	Tact Switch
S011,012	OB70130A	Tact Switch
CN1	OB83402B	2P Connector Ass'y 250mm
CN2	OB83412B	5P Connector Ass'y 300mm
CN3	OC85406A	4P Connector Ass'y 390mm
CN4	OC85407A	6P Connector Ass'y 200mm
CN5	OB83502A	6P Connector Ass'y 300mm
CN6	OC85408A	2P Connector Ass'y 150mm
CN7	OC85406A	4P Connector Ass'y
CN8	OB83404B	2P Connector Ass'y 350mm
FL001	OB90463A	FL Display FIP8CGM8
	OC85399A	Remote Control Receiver SBX-1610-52 (1)

6.8. Main P.C.B. Ass'y

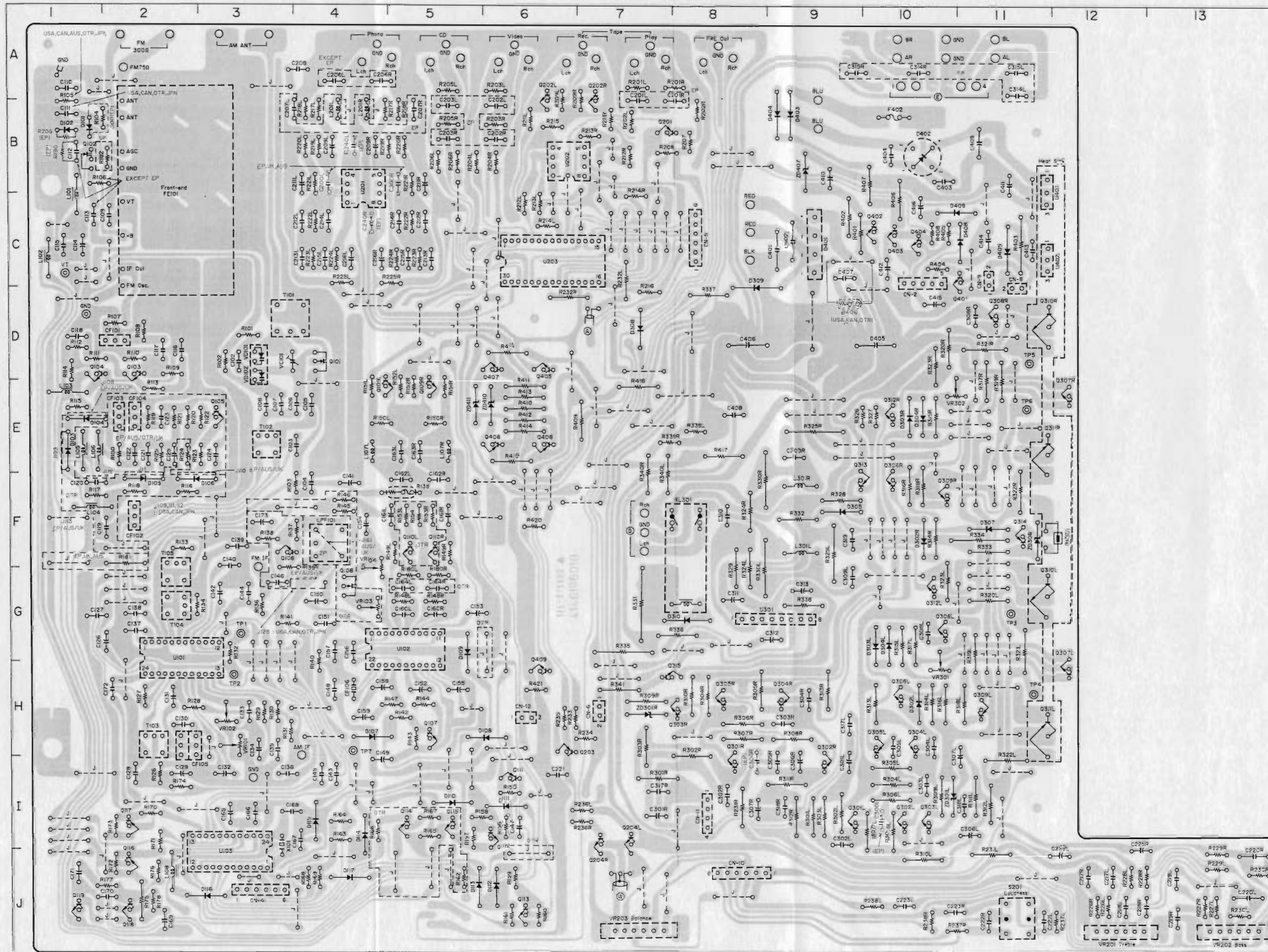

● Semiconductor Location

Ref. No.	Location
U101	G-2
U102	G-5
U103	J-3
U201	B-4
U202	B-6
U203	C-6
U301	G-8
U401	C-11
U402	C-11
Q101	D-4
Q102	B-1
Q103	D-2
Q104	D-1
Q105	E-3
Q106	F-3
Q107	H-5
Q108	G-4
Q109L	E-4
Q109R	E-5
Q110L	F-5
Q110R	F-5
Q111	I-6
Q112	I-6
Q113	J-6
Q114	I-5
Q115	I-5
Q116	J-2
Q117	I-2
Q118	J-2
Q119	J-1
Q201	B-7
Q202L	A-6
Q202R	A-7
Q203	H-6
Q204L	I-7
Q204R	J-7
Q301L	I-9
Q301R	H-8
Q302L	I-10
Q302R	H-9
Q303L	I-10
Q303R	H-7
Q304L	H-10
Q304R	H-9
Q305L	H-10
Q305R	H-8
Q306L	H-10
Q306R	E-10
Q307L	G-12
Q307R	E-12
Q308L	G-10
Q308R	D-11
Q309L	H-11
Q309R	F-10
Q310L	G-11
Q310R	D-11
Q311L	H-11
Q311R	E-11
Q312L	G-10
Q312R	E-10
Q313	E-9
Q314	F-11
Q315	H-7
Q401	C-10
Q402	C-10
Q403	C-10
Q404	C-10
Q405	D-6
Q406	E-6
Q407	D-6
Q408	E-6
Q409	H-6
ZD301L	I-10
ZD301R	H-7
ZD306	F-11
ZD407	B-9
ZD410	E-6
ZD411	E-5
VD101	D-3
VD102	D-3

Fig. 6.8



7. SCHEMATIC DIAGRAMS

7.1. IC Block Diagrams

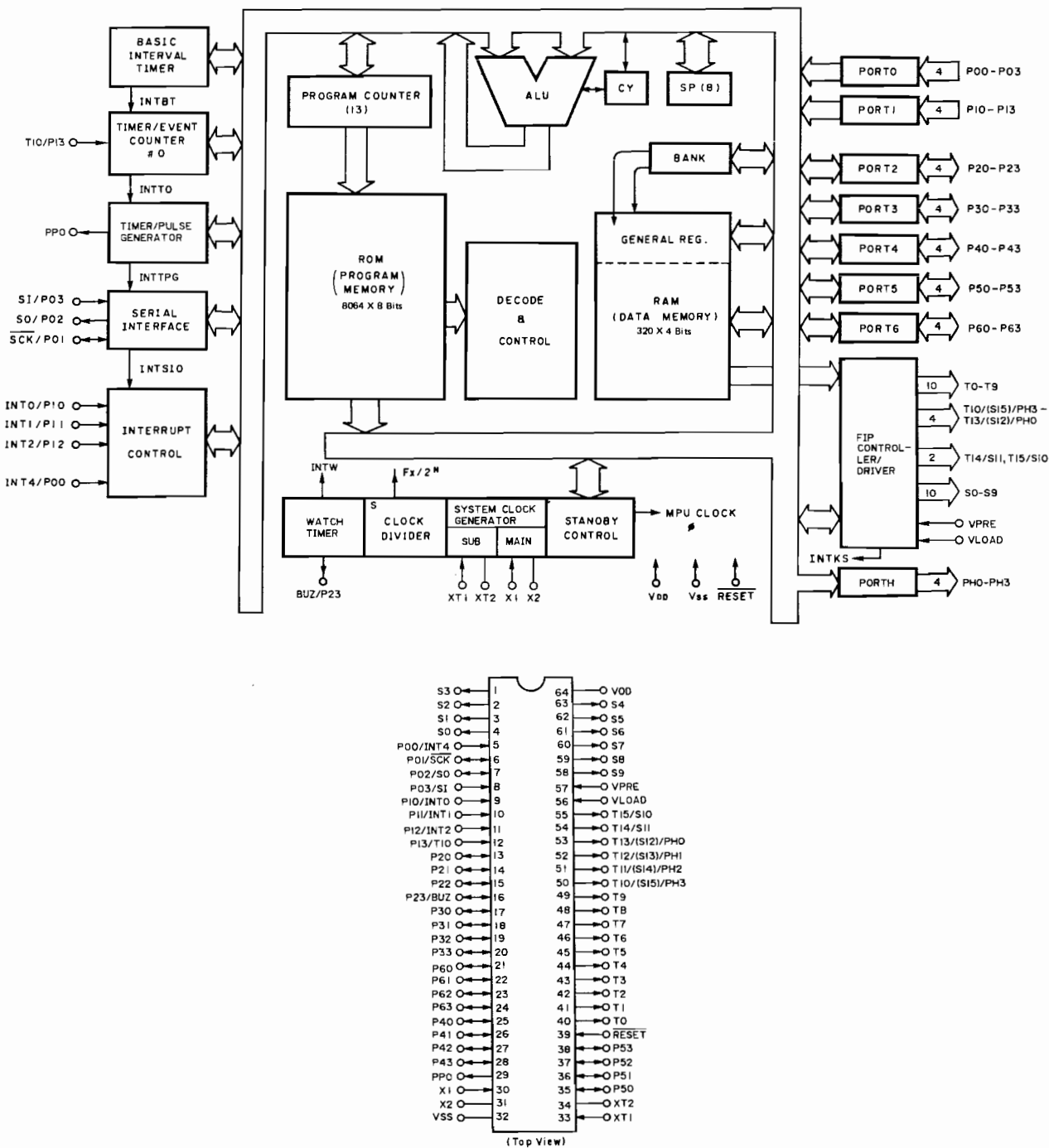

Fig. 7.1.1 MPU (U001)

U001 Microprocessing Unit (MPU) (μPD75208CW-A77)

Pin No.	Signal Name	I/O	Function
1	S3	O	Display segment drive signals/key matrix scan signals.
2	S2	O	
3	S1	O	
4	S0	O	
5	PIN	I	Power ON signal input.
6	CLK	O	Clock output for SO (pin 7) and SI (pin 8).
7	SO	O	Serial output data to U103 (PLL Frequency Synthesizer) and U203 (Analog Function Switch).
8	SI	I	Serial input data from U103.
9	IRP	I	Remote control signal input.
10	PRT	I	Power amp. protect input from U301 (Protector).
11	DUS	I	Frequency Step switch input for Other version.
12	IFS	I	IF Band switch input for Other version.
13	MO+	O	Volume motor drive signal (volume up).
14	MO-	O	Volume motor drive signal (volume down).
15	LMU	O	Line mute signal. Active "L".
16	RMU	O	Record mute signal. Active "L".
17	PCE	O	Chip enable signal sent to U103.
18	RIN	I	Remote control mode select input. Fixed to "L" to select remote control mode.
19	AIN	I	Fixed to "H".
20	BIN	I	Fixed to "H".
21	K-IN1	I	Input signals from key matrix circuit.
22	K-IN2		
23	K-IN3		
24	K-IN4		
25	AFR	O	U203 (Analog Function Switch) reset signal. Active "L".
26	ACE	O	Chip enable signal sent to U203 (Analog Function Switch).
27	SPA	O	Speaker output enable signal. H: Speaker output is enabled.
28	SPB	O	Open (not used).
29	PRO	O	Power application signal for AC outlet. H: Power is applied to the AC outlet.
30	X1	-	4.19MHz ceramic oscillator is connected.
31	X2		
32	VSS	-	GND
33	-	-	Grounded.
34	-	-	Open.
35	POL	O	Power LED drive signal. Active "L".
36	STL	O	Standby LED drive signal. Active "L".
37	PRB	O	Open (not used).
38	PRA		
39	RESET	I	System reset input. Active "L".

Pin No.	Signal Name	I/O	Function
40 to 49	T0 to T9	O	Display digit drive signals.
50	ATT	O	Open (not used).
51	VMP		
52	VM2		
53	VM1		
54	VR2		
55	VR1		
56	VLOAD	-	-33V.
57	VPRE	-	Approx. -3V.
58	IRL	O	Remote LED drive signal. H: Indicates that the Receiver 3 is receiving a remote control signal.
59 to 63	S8 to S4	O	Display segment drive signals/key matrix scan signals.
64	VDD	-	+5V.



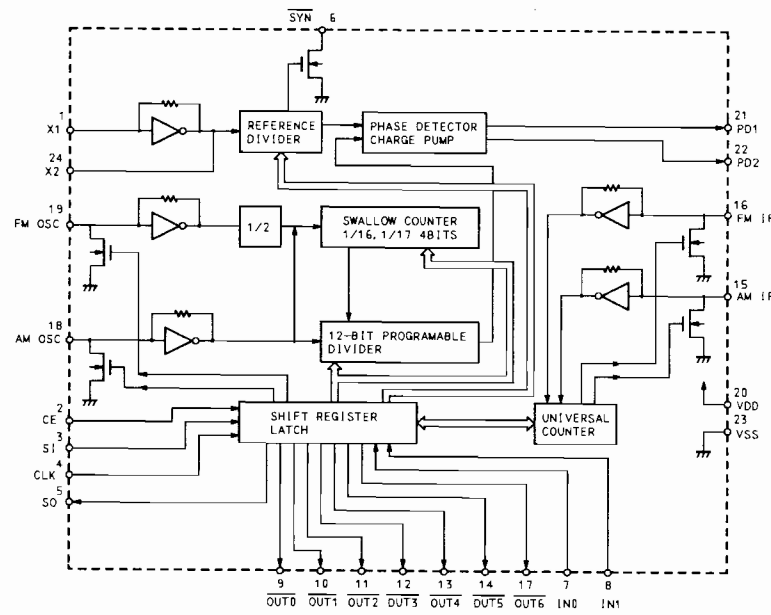

Fig. 7.1.2 PLL Frequency Synthesizer LC7218 (U103)

U103 PLL Frequency Synthesizer (LC7218)

Pin No.	Signal Name	I/O	Function
1	X1	I	7.2MHz crystal is connected.
24	X2	O	
2	CE	I	Chip enable input signal. Active "H".
3	SI	I	Serial input data from U001 (MPU).
4	CLK	I	Clock input for SI (pin 3) and SO (pin 5).
5	SO	O	Serial output data to U001.
6	SYN	O	Not used.
7	Stereo	I	Stereo signal input. L: Stereo
8	SD	I	SD signal input. H: Station is detected.
9	Wide	O	Wide signal for Other version. H: Wide, L: Narrow
10	NC	O	Open.
11	Seek Mute	O	Seek Mute signal. Active "H".
12	D $\bar{U}$	O	75 $\mu$ s/50 $\mu$ s select signal for Other version. L: 50 $\mu$ s, H: 75 $\mu$ s
13	AUT	O	Controls muting. Forcibly sets to monaural.
14	AM	O	AM mode signal. Active "L".
15	AMIF	I	AM IF signal input.
16	FM IF	I	FM IF signal input.
17	FM	O	FM mode signal. Active "L".
18	AM OSC	I	AM local oscillation signal input.
19	FM OSC	I	FM local oscillation signal input.
20	VDD	-	Approx. 5V is supplied.
21	PD1	O	PLL charge pump output. Not used.
22	PD2	O	PLL charge pump output. $f > f_{ref}$ : H, $f < f_{ref}$ : L $f = f_{ref}$ : floating
23	GND	-	GND

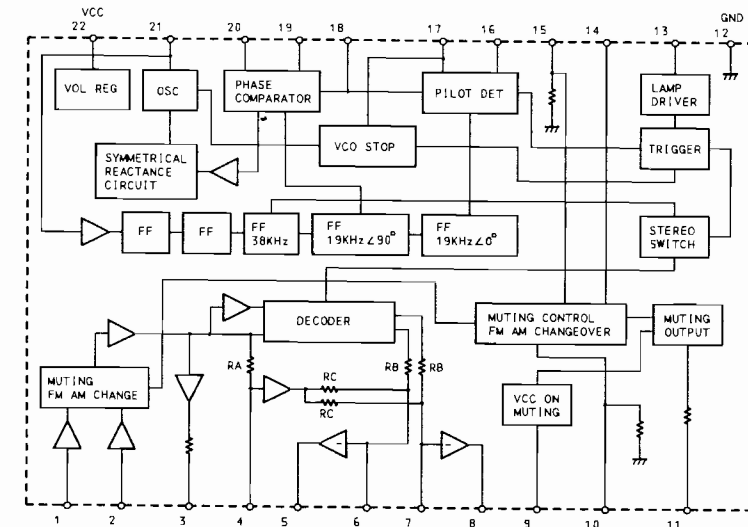

Fig. 7.1.3 Multiplexer LA3401 (U102)

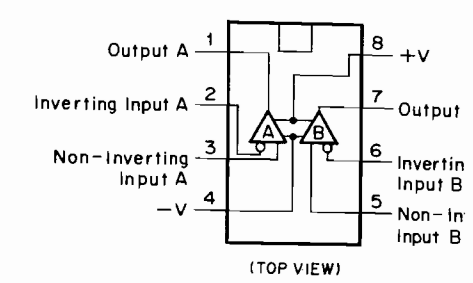

Fig. 7.1.5 Operational Amp. NJM2043DD,  $\mu$ P

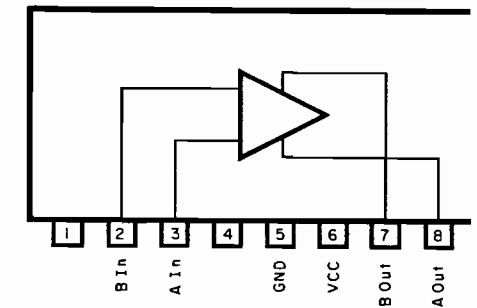

Fig. 7.1.6 Motor Driver BA6208 (U002)

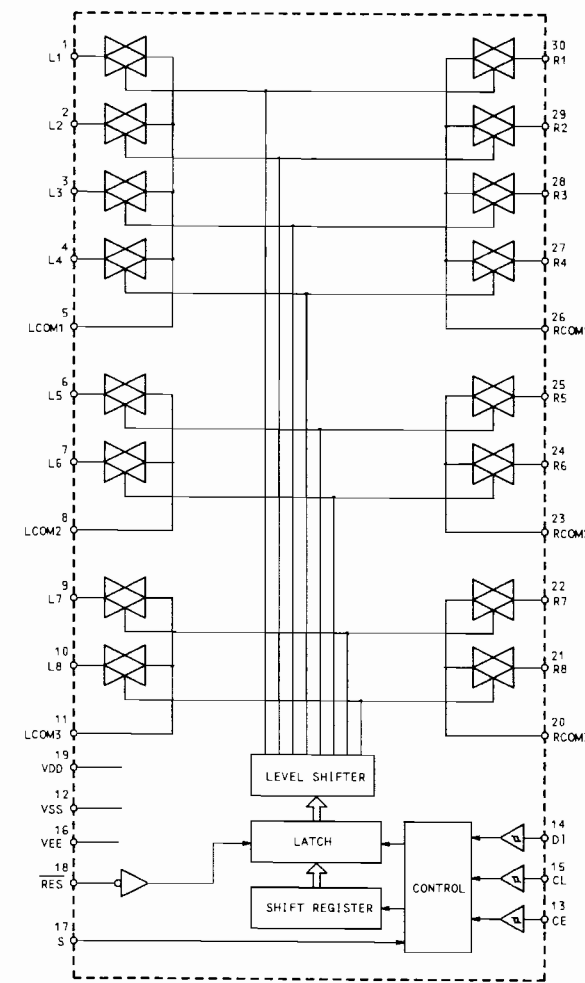

Fig. 7.1.4 Analog Function Switch LC7821 (U203)

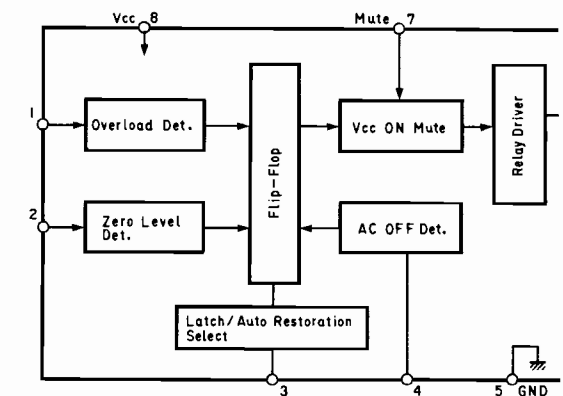
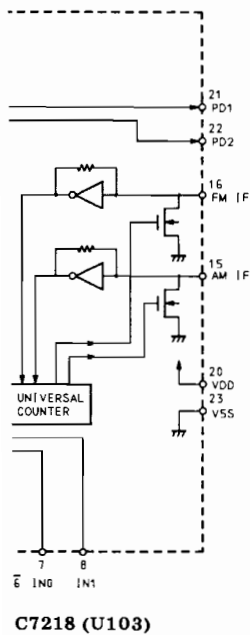

Fig. 7.1.7 Power Amp. Protector  $\mu$ PC1237 (U301)



U103 PLL Frequency Synthesizer (LC7218)

Pin No.	Signal Name	I/O	Function
1	X1	I	7.2MHz crystal is connected.
24	X2	O	
2	CE	I	Chip enable input signal. Active "H".
3	SI	I	Serial input data from U001 (MPU).
4	CLK	I	Clock input for SI (pin 3) and SO (pin 5).
5	SO	O	Serial output data to U001.
6	SYN	O	Not used.
7	Stereo	I	Stereo signal input. L: Stereo
8	SD	I	SD signal input. H: Station is detected.
9	Wide	O	Wide signal for Other version. H: Wide, L: Narrow
10	NC	O	Open.
11	Seek Mute	O	Seek Mute signal. Active "H".
12	D $\bar{U}$	O	75 $\mu$ s/50 $\mu$ s select signal for Other version. L: 50 $\mu$ s, H: 75 $\mu$ s
13	AUT	O	Controls muting. Forcibly sets to monaural.
14	AM	O	AM mode signal. Active "L".
15	AMIF	I	AM IF signal input.
16	FM IF	I	FM IF signal input.
17	FM	O	FM mode signal. Active "L".
18	AM OSC	I	AM local oscillation signal input.
19	FM OSC	I	FM local oscillation signal input.
20	VDD	-	Approx. 5V is supplied.
21	PD1	O	PLL charge pump output. Not used.
22	PD2	O	PLL charge pump output. $f > f_{ref}$ : H, $f < f_{ref}$ : L $f = f_{ref}$ : floating
23	GND	-	GND

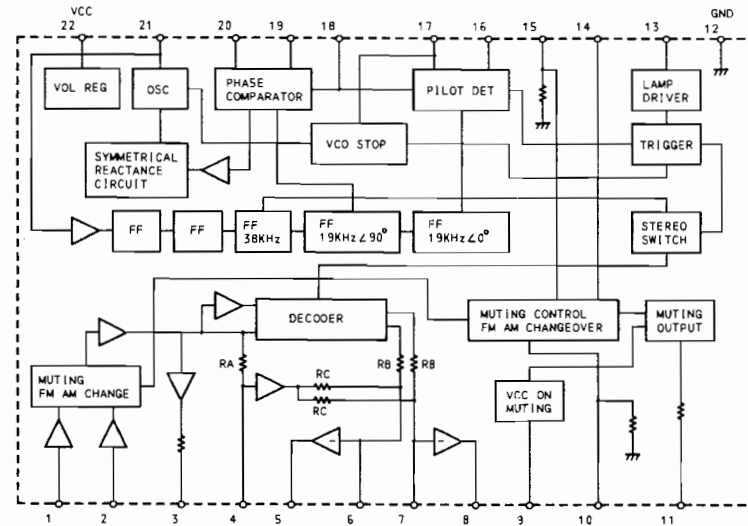

Fig. 7.1.3 Multiplexer LA3401 (U102)

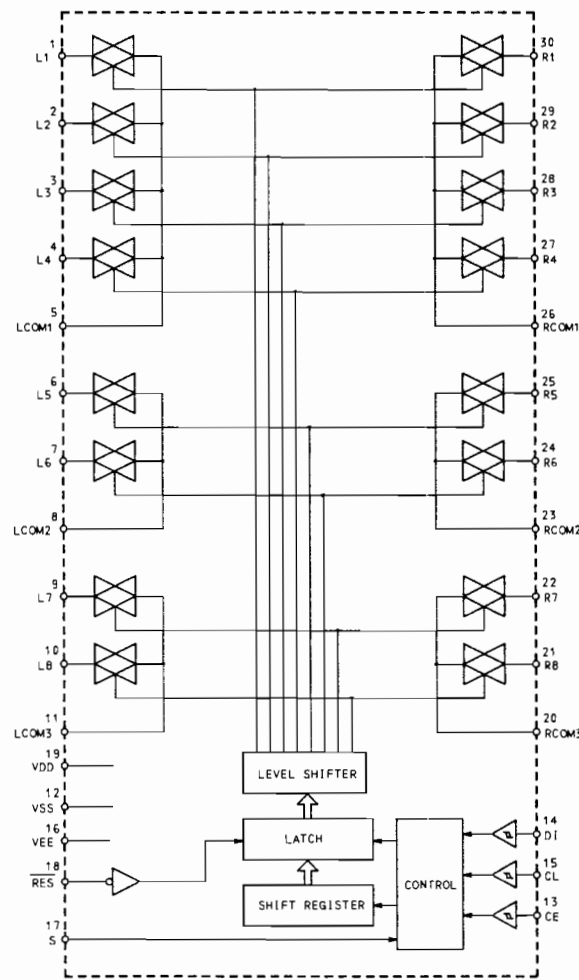

Fig. 7.1.4 Analog Function Switch LC7821 (U203)

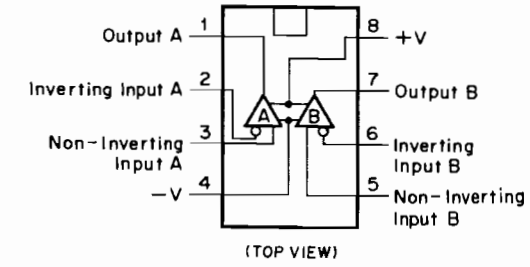

Fig. 7.1.5 Operational Amp. NJM2043DD,  $\mu$ PC4570C

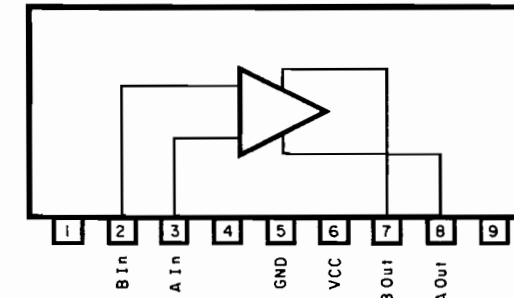

Fig. 7.1.6 Motor Driver BA6208 (U002)

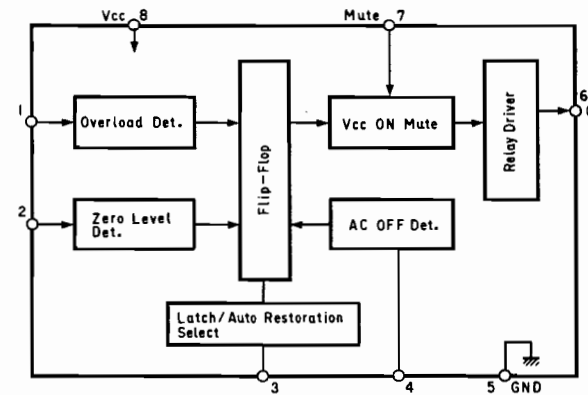

Fig. 7.1.7 Power Amp. Protector  $\mu$ PC1237 (U301)

7.2. Schematic Diagrams

(1) Tuner Section

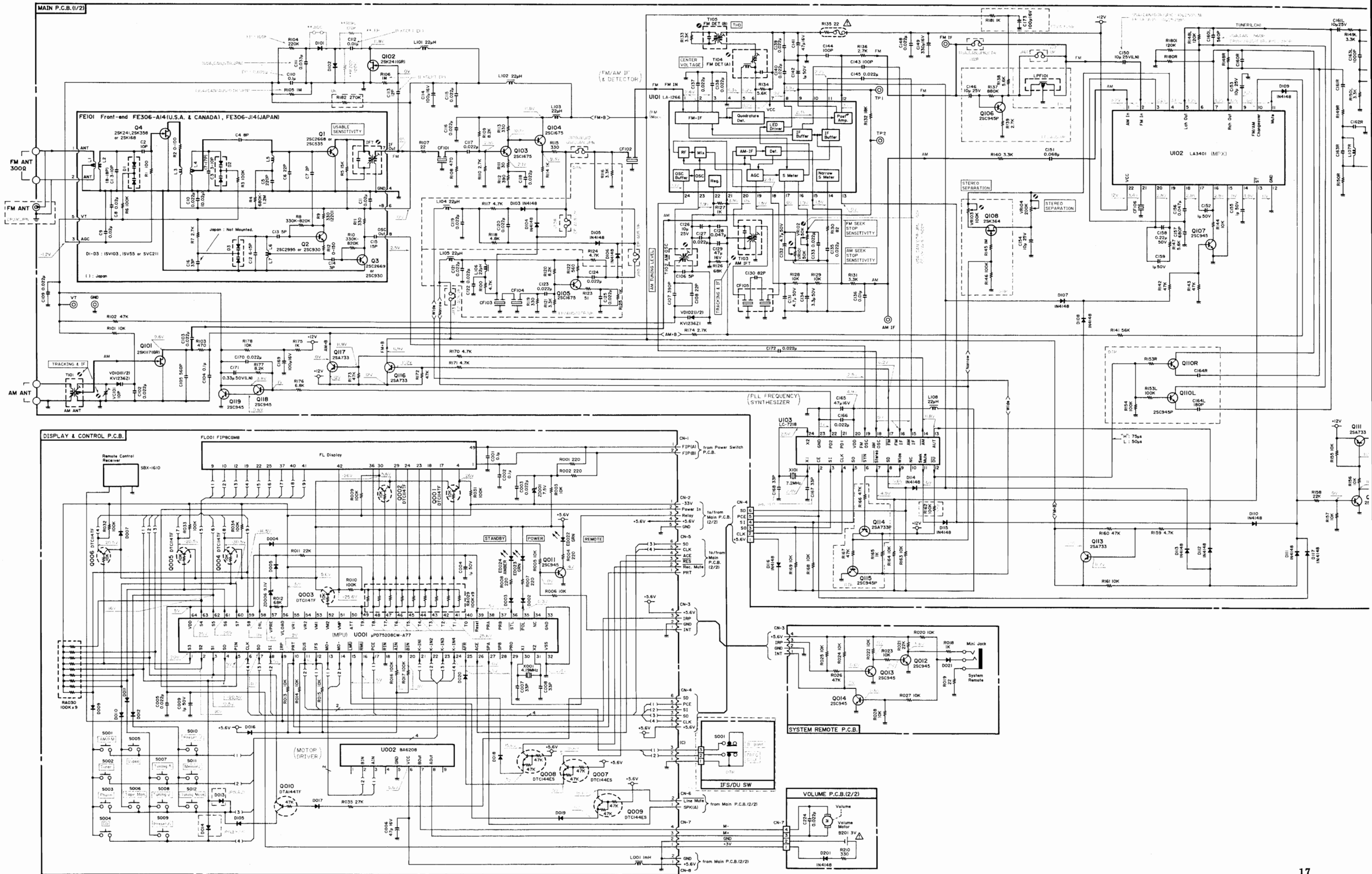
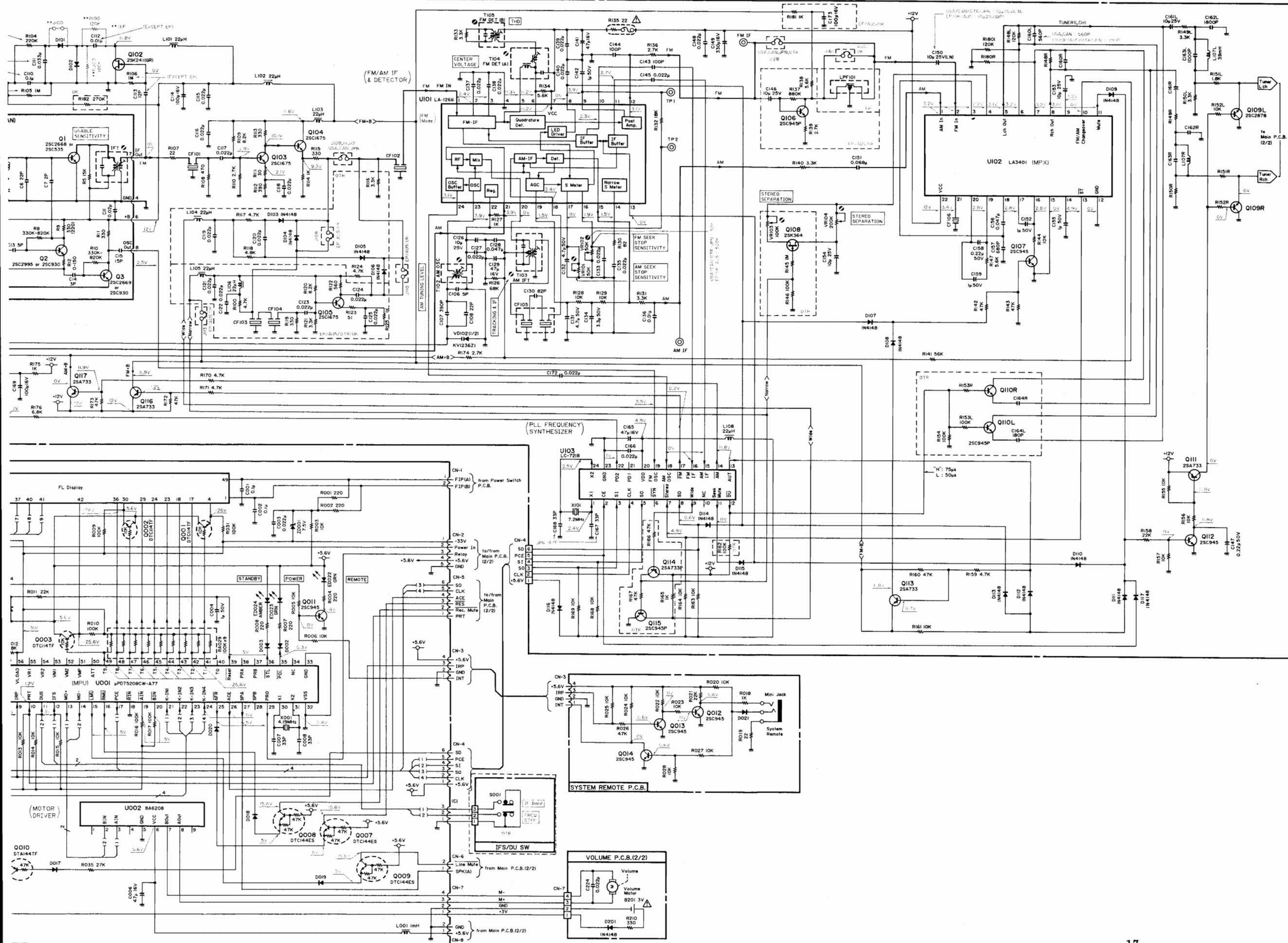

Fig. 7.2.1













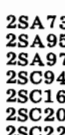

-  DTC144ES
-  2SA733
-  2SA953
-  2SA970
-  2SC945
-  2SC1675
-  2SC2002
-  2SC2240
-  2SC2878
-  DTA114TF
-  DTC114TF
-  2SA1264
-  2SC3181
-  2SA965
-  2SC2235
-  7805
-  7812
-  2SK117
-  2SK241

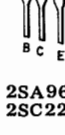
Fig. 7.2.1

(2) Amplifier Section

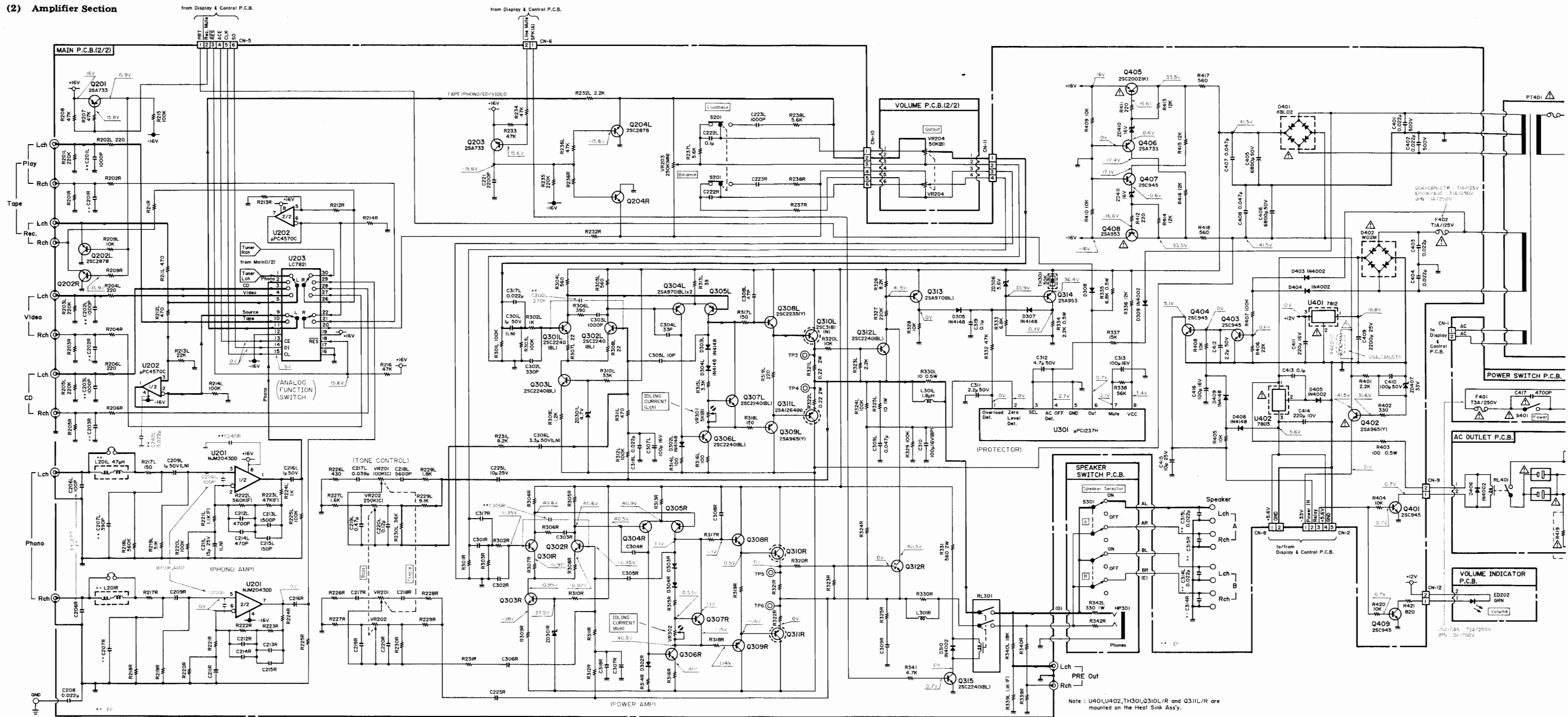



Fig. 7.2.2

- Notes: 1. Diode is 1SS176, 1SS53, or 1S1555 unless otherwise specified.  
 2. 2SA733, 2SA608SP, 2SA1048 and 2SA1175 are interchangeable with each other.  
 3. 2SC945, 2SC536SP, 2SC2458 and 2SC2785 are interchangeable with each other.  
 4. Voltage measuring conditions  
 ● With no input signal applied to the input terminals.  
 ● With no load connected to the speaker terminals.

**WARNING:**  
 Parts marked with the symbol  have  
 teristics.  
 Use **ONLY** replacement parts recomm  
 manufacturer.  
 It is recommended that the unit be op  
 suitable DC supply or batteries during i  
 procedures.

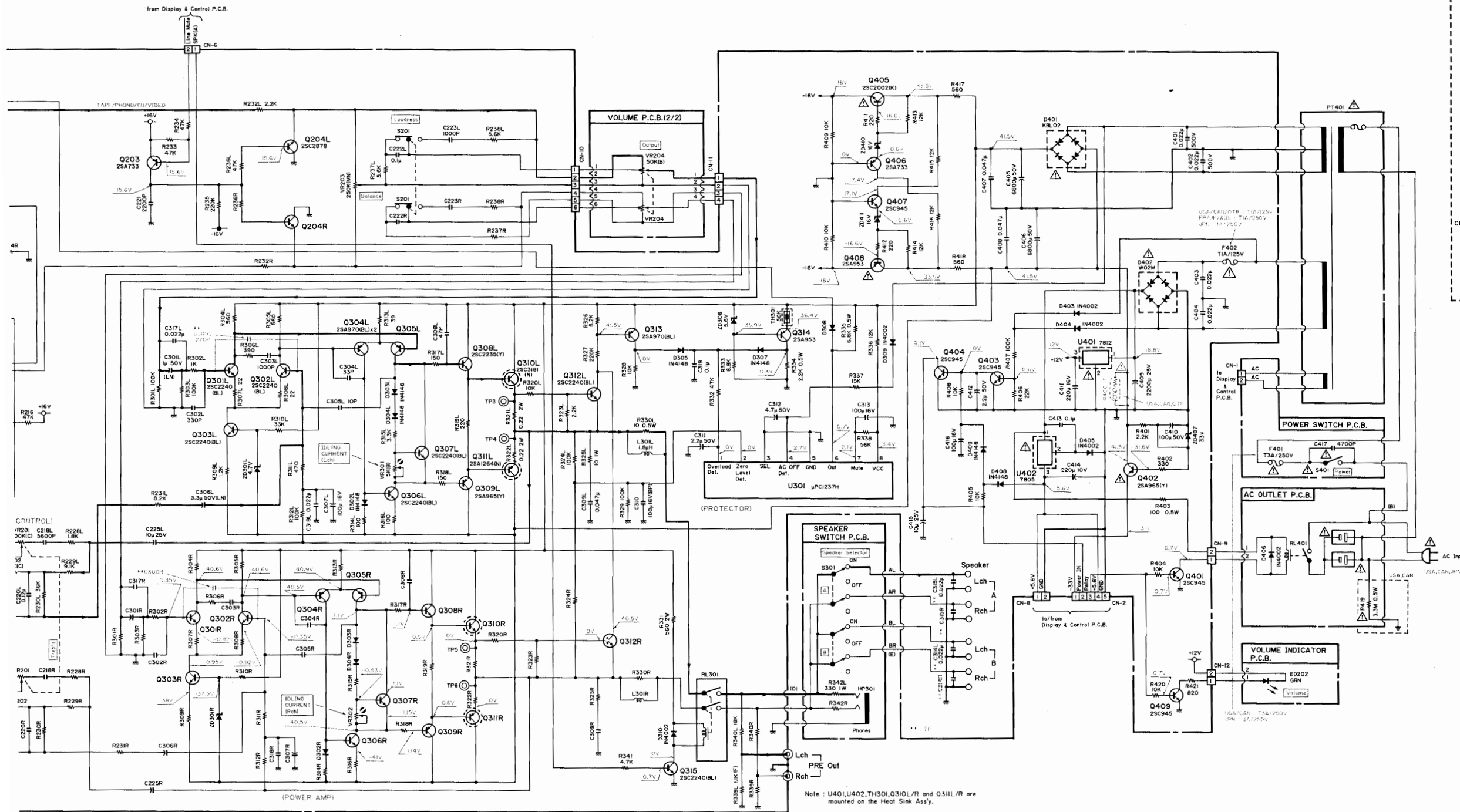
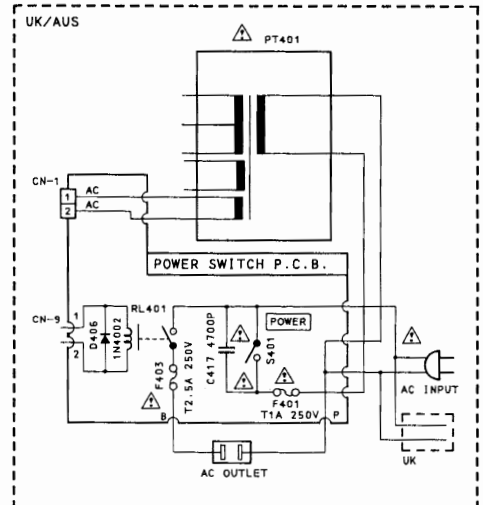
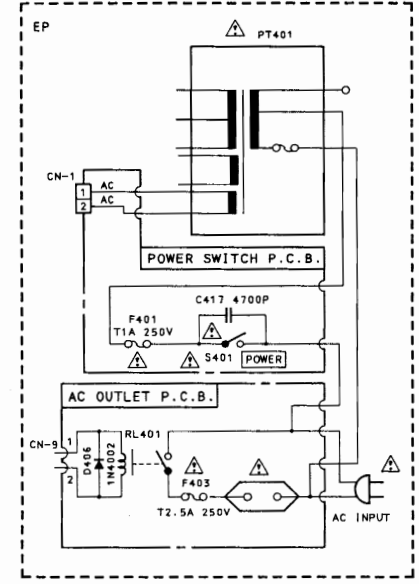
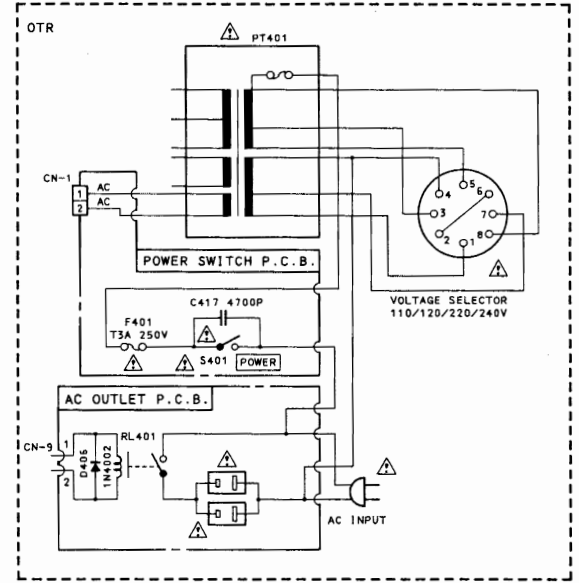



Fig. 7.2.2

Note: U401, U402, TH301, Q310L/R and Q311L/R are mounted on the Heat Sink Ass'y.



ified.  
angeable with each other.  
angeable with each other.

**WARNING:**  
Parts marked with the symbol  have critical characteristics.  
Use ONLY replacement parts recommended by the manufacturer.  
It is recommended that the unit be operated from a suitable DC supply or batteries during initial check-out procedures.

8. WIRING DIAGRAM

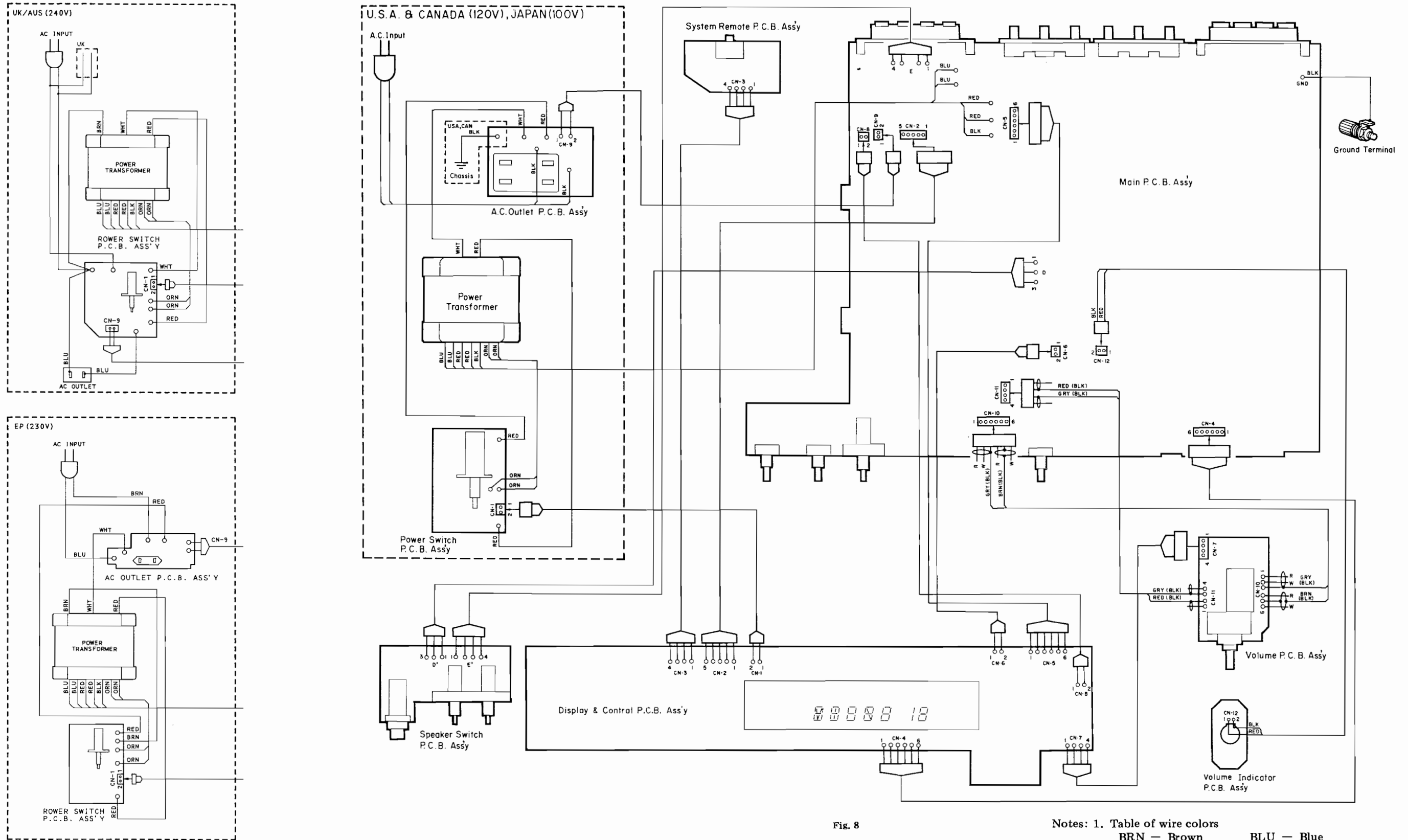

Fig. 8

- Notes: 1. Table of wire colors
- |              |              |
|--------------|--------------|
| BRN - Brown  | BLU - Blue   |
| RED - Red    | VIO - Violet |
| ORN - Orange | GRY - Gray   |
| YEL - Yellow | WHT - White  |
| GRN - Green  | BLK - Black  |
2. Component side view of the P.C.B. is illustrated unless otherwise
3. Wire tube color is shown in ( ).

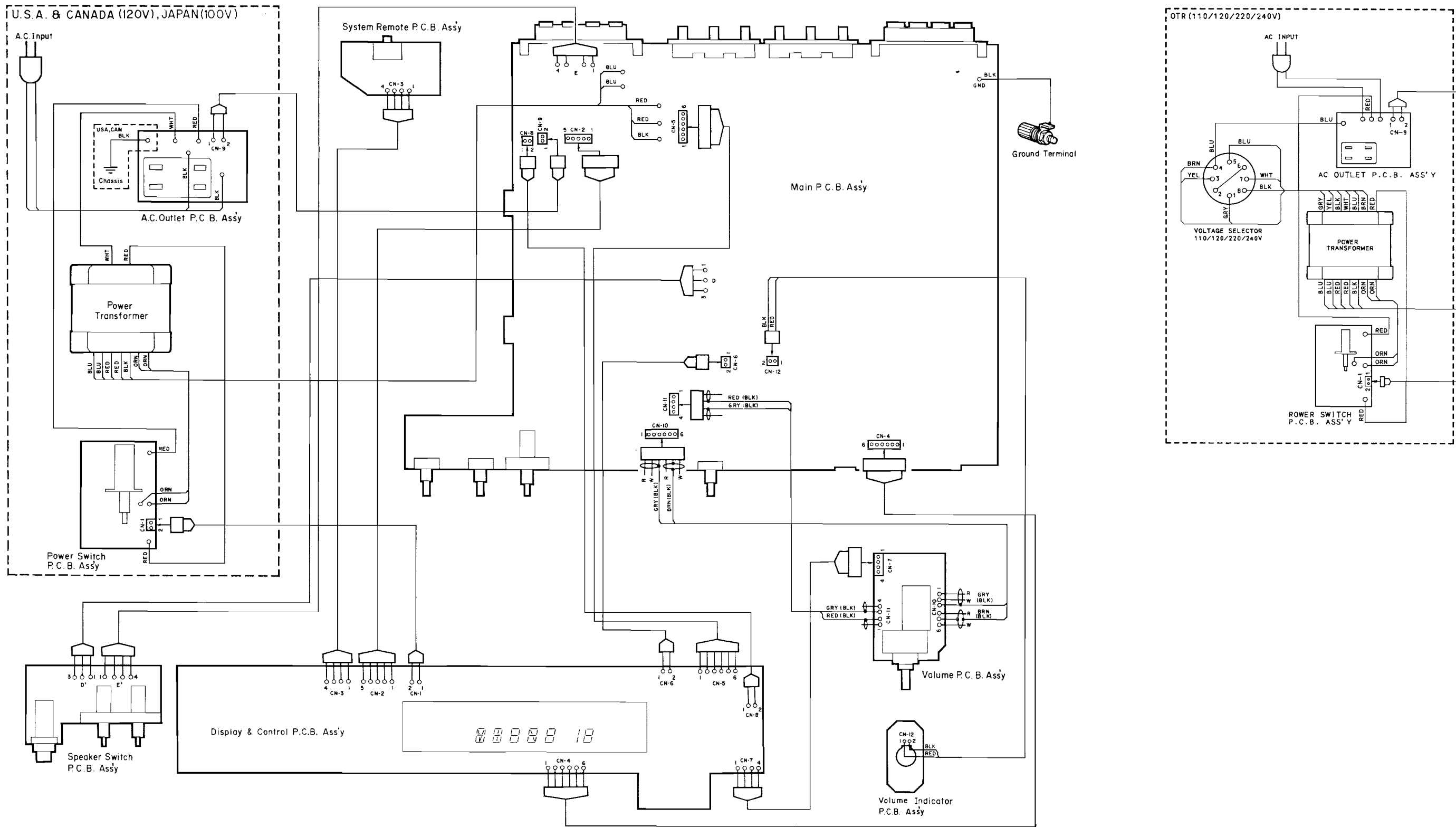

Fig. 8

Notes: 1. Table of wire colors

BRN — Brown	BLU — Blue
RED — Red	VIO — Violet
ORN — Orange	GRY — Gray
YEL — Yellow	WHT — White
GRN — Green	BLK — Black

2. Component side view of the P.C.B. is illustrated unless otherwise specified.

3. Wire tube color is shown in ( ).



9. BLOCK DIAGRAMS

(1) Tuner & Display Control Section

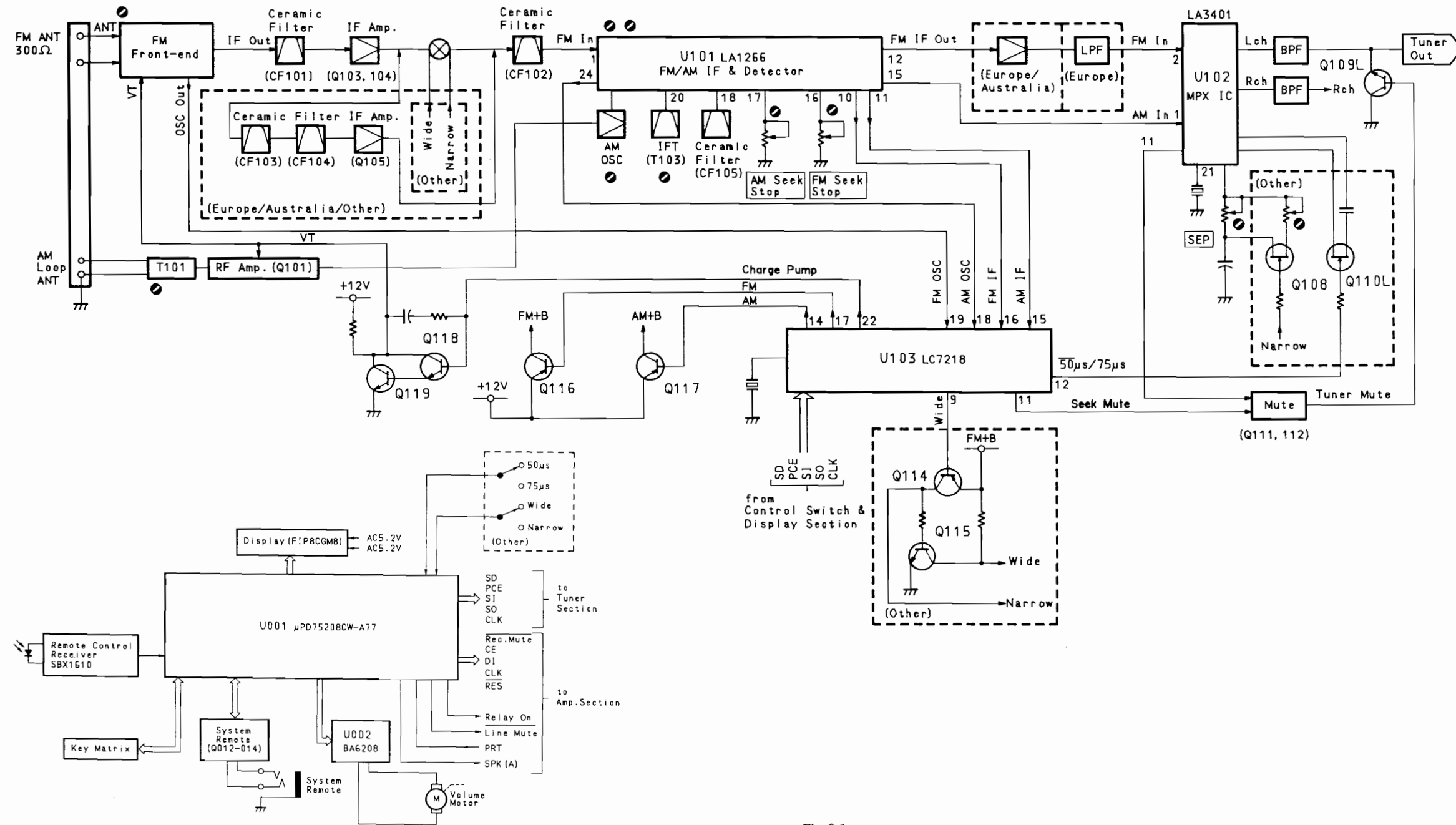

Fig. 9.1

(2) Amplifier Section

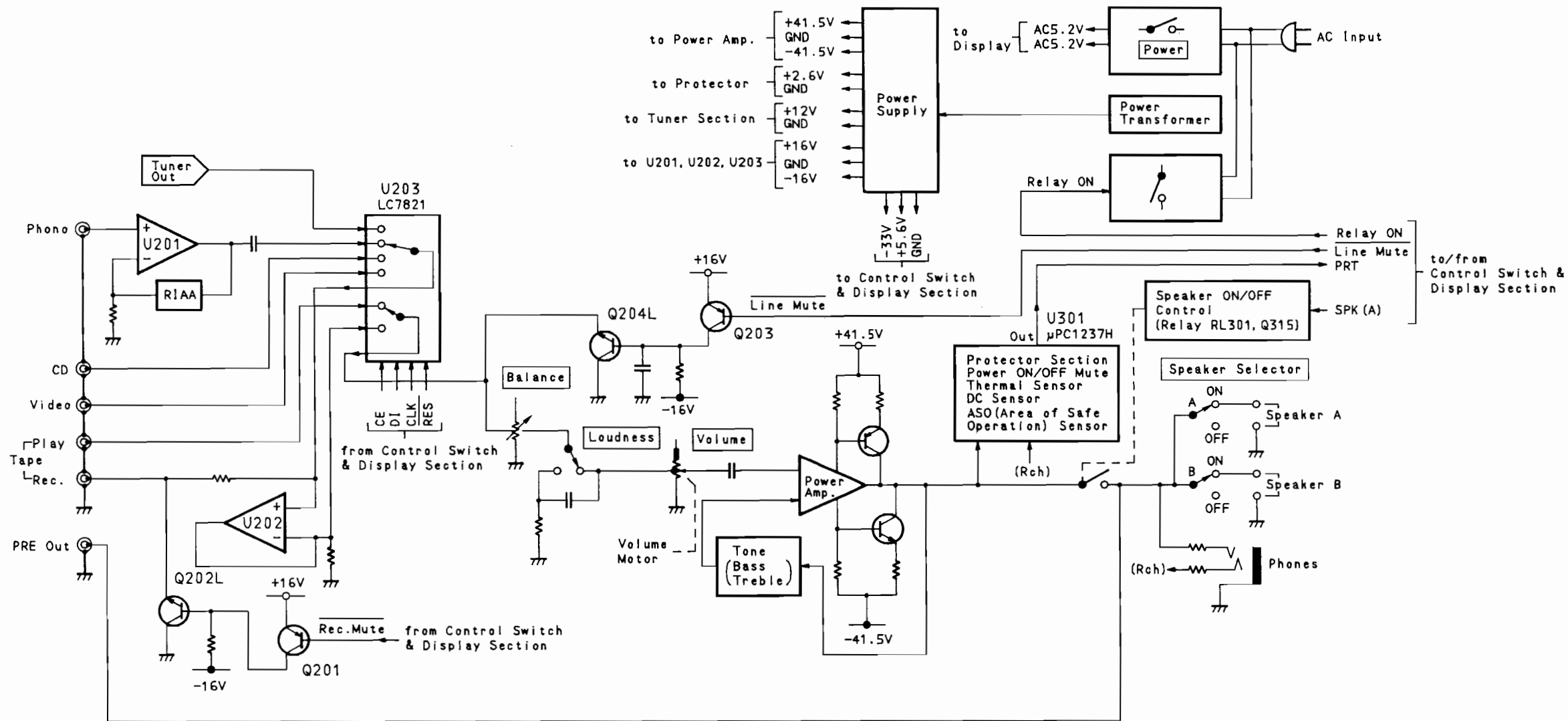

Fig. 9.2

## 10. SPECIFICATIONS

### ● Power Amplifier Section

Note: Unless noted otherwise, specifications are in accordance with IHF-A-202 measured from any high-level input (CD/VIDEO/TAPE) to the speaker output.

Continuous Average Output Power . . . 37 watts per channel into 8 ohms, both channels driven, 20–20,000 Hz, at no greater than 0.1% THD  
Dynamic Output Power . . . . . 55 watts per channel into 8 ohms  
70 watts per channel into 4 ohms  
Power Bandwidth . . . . . 10–40,000 Hz  
Frequency Response . . . . . 20–20,000 Hz; ±1 dB  
10–50,000 Hz; +1, –3 dB  
Signal-to-Noise Ratio . . . . . Better than 98 dB re rated power  
(A-WTD, input shorted) . . . . . Better than 83 dB (IHF-A-202)  
Total Harmonic Distortion . . . . . Less than 0.1%  
(8 ohms, rated power,  
20 Hz–20 kHz)  
Headphone Rated Output . . . . . 86 mW  
(40 ohms)  
Output Current Capability . . . . . 10 A peak per channel

### ● Preamplifier Section

Note: Unless noted otherwise, specifications are in accordance with IHF-A-202. Except for sensitivity, S/N, tone control and loudness characteristics (which are measured to the speaker outputs), measurements are made from the specified input to Rec Out.

Sensitivity (for rated output)  
Phono MM . . . . . 2.5 mV  
CD/Tape . . . . . 150 mV  
Sensitivity (for 1-watt output, IHF-A-202)  
Phono MM . . . . . 0.41 mV  
CD/Tape . . . . . 25 mV  
Input Impedance  
Phono MM . . . . . 47 kohms  
CD/Tape . . . . . 20 kohms  
Maximum Input Level (1 kHz)  
Phono MM . . . . . 150 mV  
Pre Output Level/Impedance . . 1.0 V/1 kohms  
Record Output Level/ . . . . . 150 mV/1.5 kohms  
Impedance  
Total Harmonic Distortion (1 kHz, to Rec Out, at 1 V)  
Phono MM . . . . . Less than 0.01%  
RIAA Deviation  
Phono MM . . . . . 30–20,000 Hz ±1 dB  
Signal-to-Noise Ratio (to speaker output, IHF-A-202)  
Phono MM . . . . . Better than 78 dB  
Tone Controls  
Bass . . . . . 20 Hz, ±10 dB  
Treble . . . . . 20 kHz, ±10 dB  
Loudness (volume: –30 dB) . . . 20 Hz, +10 dB; 20 kHz, +6 dB

### ● Tuner Section

[FM]

Note: All RF levels in microvolts given re 300-ohm antenna input.  
Modulation: Mono 100%, Stereo Pilot 9%, Stereo Audio Signal 91%.

Frequency Range . . . . . 87.5–107.9 MHz in 200 kHz steps  
IHF Usable Sensitivity (Mono) . 12.0 dBf/2.2 μV  
50-dB Quieting Sensitivity  
Mono . . . . . 15.7 dBf/3.3 μV,  
Stereo . . . . . 38.5 dBf/46.1 μV  
Signal-to-Noise Ratio at 65 dBf  
Mono . . . . . Better than 78 dB  
Stereo . . . . . Better than 69 dB  
Muting Threshold . . . . . 30 dBf/17.3 μV  
Frequency Response . . . . . 30–15,000 Hz ±1.5 dB

Total Harmonic Distortion (1 kHz)

Mono . . . . . Less than 0.15%  
Stereo . . . . . Less than 0.20%  
Capture Ratio . . . . . 2.0 dB  
Alternate Channel Selectivity . . 55 dB (±400 kHz)  
Stereo Separation at 1 kHz . . . . Better than 45 dB  
Spurious Response Rejection . . . Better than 80 dB  
Image Rejection . . . . . Better than 47 dB  
IF Rejection . . . . . Better than 80 dB  
AM Suppression . . . . . Better than 60 dB

[AM]

Note: Modulation—400 Hz, 30%

Frequency Range . . . . . 520–1,710 kHz in 10 kHz steps,  
Sensitivity . . . . . 53 dBμ/m  
Signal-to-Noise Ratio at . . . . . Better than 52 dB  
90 dBμ/m  
Total Harmonic Distortion . . . . . Less than 0.5%  
at 90 dBμ/m  
Selectivity . . . . . Better than 20 dB (±10 kHz)

### ● General

Power Source . . . . . 120 VAC, 50/60 Hz  
Power Consumption . . . . . 220W max.  
Convenience Outlets . . . . . Switched: 2  
Dimensions\* . . . . . 430 (W) x 100 (H) x 275 (D) mm  
16-15/16 (W) x 3-15/16 (H) x 10-13/16 (D) inches  
Approximate Weight . . . . . 6.0 kg, 13 lbs. 4 oz.

### ● Remote Control Unit

Principle . . . . . Infrared pulse system  
Power Supply . . . . . 3 VDC (1.5 V x 2)  
Dimensions\* . . . . . 63 (W) x 18 (H) x 148 (D) mm  
2-1/2 (W) x 11/16 (H) x 5-13/16 (D) inches  
Approximate Weight . . . . . 120 g, 4 oz. (including batteries)

\*: Dimensions do not include protruding parts. Height is the panel height without feet.

● Specifications and design are subject to change for further improvement without notice.