

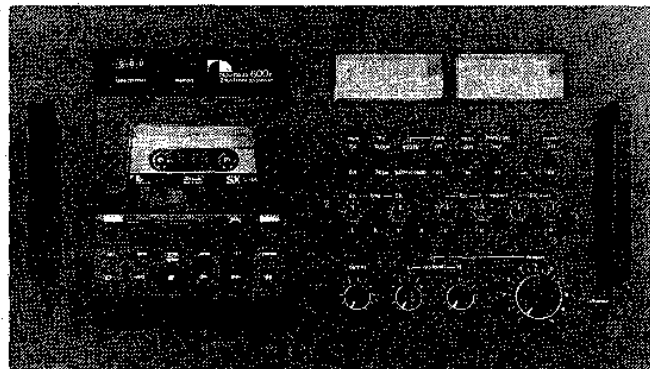

Service Manual

Nakamichi 600II

2 Head Cassette Console



1. General	3
2. Principle of Operation	5
2. 1. 2-Head Configuration	5
2. 2. Playback Eq. Amp. Circuit	7
2. 3. Test Tone Circuit	8
2. 4. Bias Osc. Circuit	9
2. 5. Unattended Record or Playback, and Shut-off Circuit	9
2.5.1. Unattended Record or Playback	9
2.5.2. Shut-off Circuit	9
3. Removal Procedures	13
3. 1. Cassette Lid Plate	13
3. 2. Cabinet	13
3. 3. Volume Cap	13
3. 4. Handle Ass'y	13
3. 5. Front Panel Ass'y	13
3. 6. Mechanism Ass'y	13
3. 7. Front Control Ass'y	13
3. 8. Volume P.C.B. Ass'y	13
3. 9. Record/Playback Head Ass'y, Erase Head and Pressure Roller Ass'y	14
3. 10. Cassette Case Ass'y	14
3. 11. Cassette Lid Ass'y	14
3. 12. Control Button Ass'y	14
3. 13. Counter Holder Ass'y	15
3. 14. Reel Hub Ass'y (Supply, Take-up)	15
3. 15. Shield Cover, Motor and Motor Governor	15
3. 16. Flywheel Ass'y	16
3. 17. Idler Pulley Ass'y	16
3. 18. Main P.C.B. Ass'y	16
3. 19. Dolby NR P.C.B. Ass'y	16
3. 20. Meter Ass'y	16
3. 21. Power Switch Ass'y	16
3. 22. Record Link Ass'y	16
3. 23. Rear Panel Ass'y	16
3. 24. Power Supply P.C.B. Ass'y	16
3. 25. Headphone Jack	16
4. Measurement and Maintenance Instrument	17
4. 1. Measurement Instrument	18
4. 2. Maintenance Instrument	18
5. Mechanical Adjustments	18
5. 1. Take-up Torque and Rewind Torque Adjustment	18
5. 2. Tape Speed Adjustment	18
5. 3. Headblock Adjustment	19
5.3.1. Adjustment of Tape Guide Height (Erase, Record/Playback)	19
5.3.2. Record/Playback Head Height Adjustment and Azimuth Alignment	19
5. 4. Head Base Stroke Adjustment	19
5. 5. Pause Timing Adjustment	20
5. 6. Belt Travelling Adjustment	20
5. 7. Flywheel Adjustment	20
5. 8. Brake Timing Adjustment	20
5. 9. Mute Switch and Start Switch Adjustment	21
5. 10. Solenoid Position Adjustment	22
5. 11. Record Link Adjustment	22
5. 12. Lubrication	22
5. 13. Tape Travelling Adjustment	23
6. Electrical Adjustments and Measurements	24
6. 1. Adjustment and Measurement Instructions	24

6. 2. Frequency Response Adjustment	27
6.2.1. Playback Frequency Response Adjustment	27
6.2.2. Record Current Frequency Response Adjustment	27
7. Parts Location for Electrical Adjustment	28
8. Mounting Diagram and Parts List	28
8. 1. Dolby NR P.C.B. Ass'y	28
8. 2. Main P.C.B. Ass'y	29
8. 3. Cal. A P.C.B. Ass'y	31
8. 4. Cal. B P.C.B. Ass'y	31
8. 5. Switch P.C.B. Ass'y	32
8. 6. VR P.C.B. Ass'y	32
8. 7. Meter P.C.B. Ass'y	33
8. 8. DIN Pin Jack P.C.B. Ass'y	33
8. 9. Power Supply P.C.B. Ass'y	34
8. 10. Shut-off P.C.B. Ass'y	35
8. 11. MHX Governor B	35
9. Mechanism Ass'y and Parts List	37
9. 1. Synthesis (A01)	37
9. 2. Chassis Ass'y	38
9.2.1. Chassis Ass'y (1/2) (A02-1)	38
9.2.2. Chassis Ass'y (2/2) (A02-2)	39
9. 3. 600II Mechanism Ass'y (A03)	41
9. 4. Front Control Ass'y (A04)	43
9. 5. Record Link Ass'y (A05)	43
9. 6. Push Button Ass'y (A06)	43
9. 7. Rear Panel Ass'y (A07)	45
9. 8. Power Transformer Ass'y (A08)	45
9. 9. Power Switch Ass'y (A09)	45
9. 10. Meter Ass'y (A10)	45
9. 11. Mechanism Ass'y	47
9.11.1. Mechanism Ass'y (1/2) (B01-1)	47
9.11.2. Mechanism Ass'y (2/2) (B01-2)	49
9. 12. Cassette Case Ass'y (B02)	51
9. 13. Head Base B Ass'y (B03)	51
9. 14. Counter Holder Ass'y (B04)	51
9. 15. Flywheel Holder C Ass'y (B05)	51
9. 16. MHX Motor Ass'y B (B06)	51
9. 17. Record/Playback Head Ass'y (B07)	52
10. Wiring Diagram	53
11. Eq. Amp. Frequency Response	54
11. 1. Playback Frequency Response	54
11. 2. Record Current Frequency Response	54
12. Block Diagram	54
13. Schematic Diagram	55
13. 1. Amplifier	55
13. 2. Mechanism	56
14. Troubleshooting	58
14. 1. Note	58
14. 2. Troubleshooting	58
14. 3. Check Method When Parts are Replaced	60
15. Specifications	62

1. GENERAL

Nakamichi 600II control functions are shown with reference to the following explanations.

To maintain the optimum performance of Nakamichi 600II, maintenance such as cleaning of head, capstan shaft and pressure roller, and demagnetization of heads, lubrication, etc. are required.

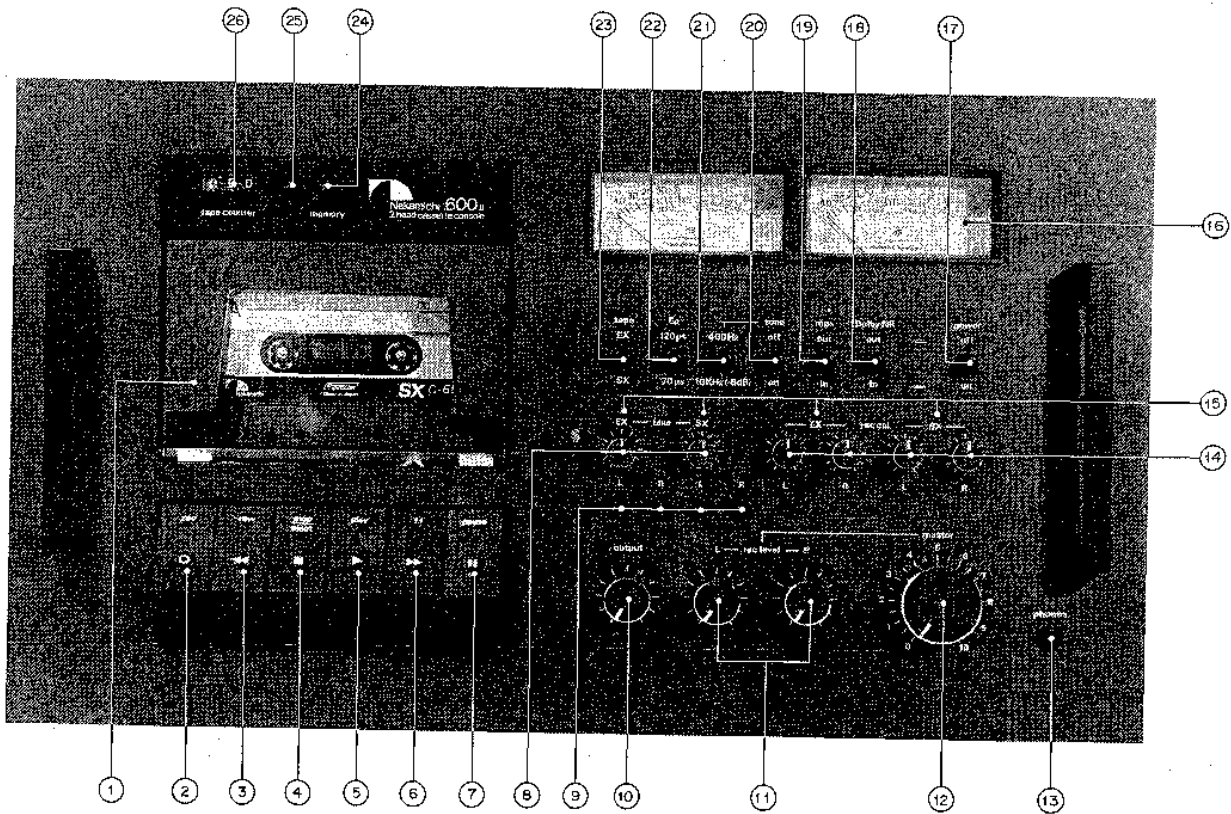

Fig. 1.1 Front View (Black)

- | | |
|---------------------------------|----------------------------------|
| 1. Cassette Lid | 17. Power Switch |
| 2. Record Button | 18. Dolby NR Switch |
| 3. Rewind Button | 19. MPX Switch |
| 4. Stop/Eject Button | 20. Test Tone Switch |
| 5. Playback Button | 21. Test Tone Frequency Switch |
| 6. Fast Forward Button | 22. Eq. Switch |
| 7. Pause Button | 23. Tape Switch |
| 8. Bias Adjustment Controls | 24. Tape Start Memory Switch |
| 9. Bias Calibration Controls | 25. Tape Counter Reset Button |
| 10. Output Level Control | 26. Tape Counter |
| 11. Record Level Controls | 27. Line Input Jacks |
| 12. Master Input Level Control | 28. DIN Socket |
| 13. Headphone Jack | 29. Line Output Jacks |
| 14. Record Calibration Controls | 30. AC Line Cord |
| 15. Lamps | 31. Speed Calibration Adjustment |
| 16. Peak Level Meters | |

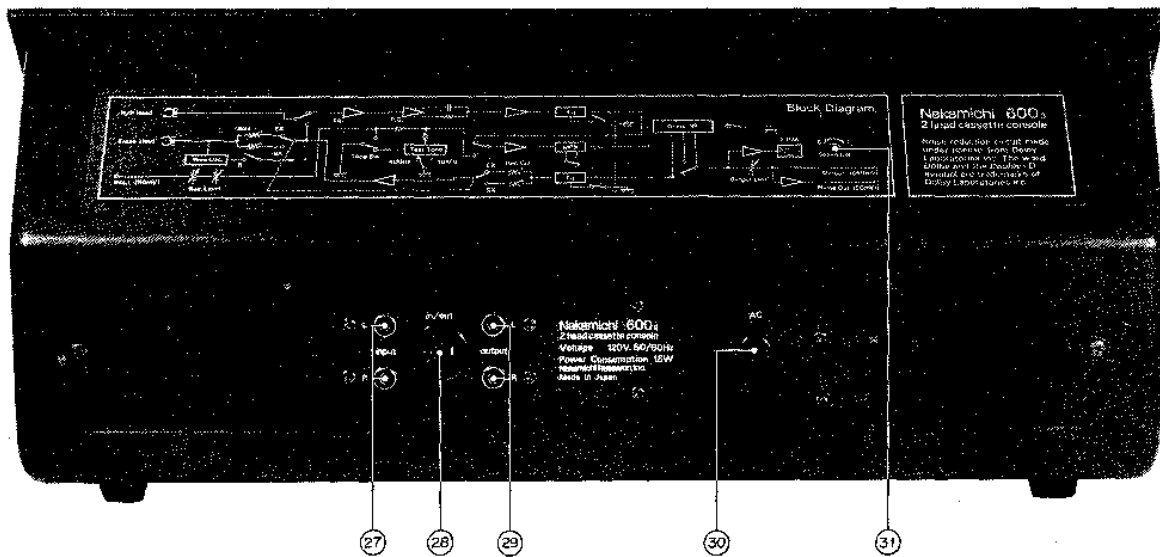

Fig. 1.2 Rear View

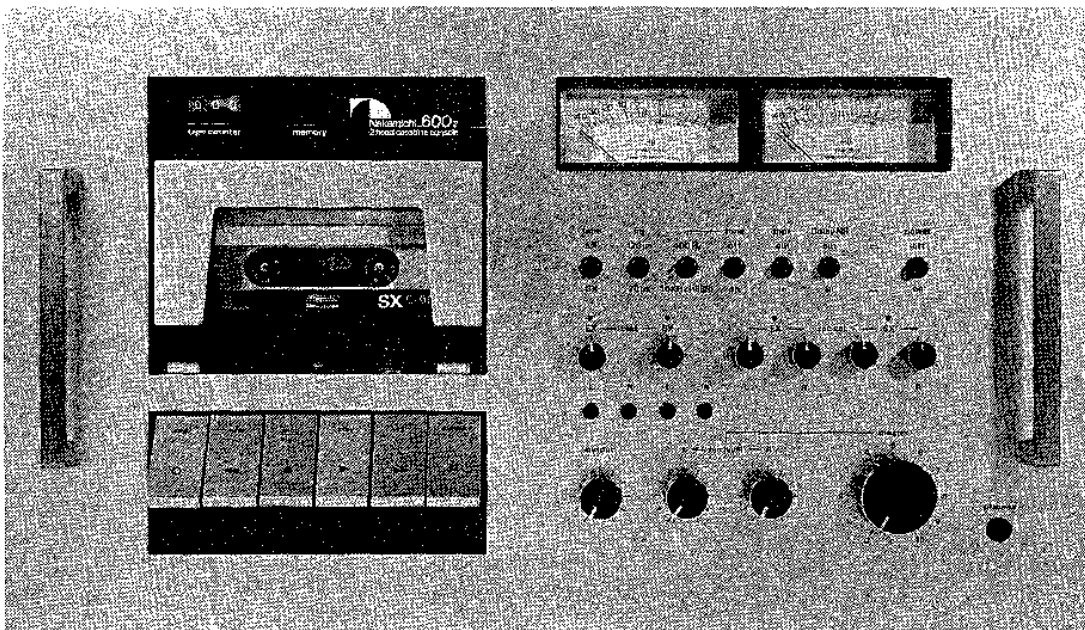

Fig. 1.3 Front View (Silver)

- Notes:
1. When cassette lid is opened, no control button operates.
 2. With record mode and tone switch ON, 400 Hz or 10 kHz test tone oscillates by the selection of test tone frequency switch 400 Hz or 10 kHz.
 3. When mechanism ass'y is reassembled, check to insure whether the record link ass'y (see Fig. 3.12) is fixed to the correct position, i.e. when record button is depressed (cassette is loaded), record link acts.
 4. When memory counter is in a range of "000" to "010", memory rewind stop function (stops at "999") does not operate because of less rewind time until "999" the electric charge for the capacitor which will conduct to drive the solenoid to shut-off is insufficient.

2. PRINCIPLE OF OPERATION

2.1. 2-Head Configuration

Despite the fact that the N-600II is of 2-head cassette tape deck, it will provide you with performance up to 20 kHz. To arrive at such performance, the N-600II now incorporates 2 great improvements.

One of them is further improvement of record/playback head and the other being the improvement of headblock, in other words, narrower gap of the record/playback head increased the playback frequency response at highs, and modification of the headblock has resulted in more stabilized tape travel.

Accuracy of tape travel is one of the most essential factors for a device to optimize its performance. Inaccurate tape travel will therefore induce deterioration exemplified by the following:

- vibration will be given to tape travel, as a result of which flutter and modulation noise will become increased
- insufficient tape-to-head contact will result in level drops
- tape skew will become greater and frequency response will become decreased

Needless to say, constant tape travel must consist of smooth drive mechanism, as well as of the fact that tape,

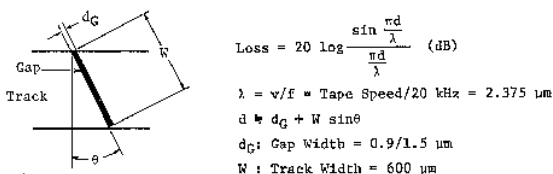

Fig. 2.1.1 Equivalent Gap Width

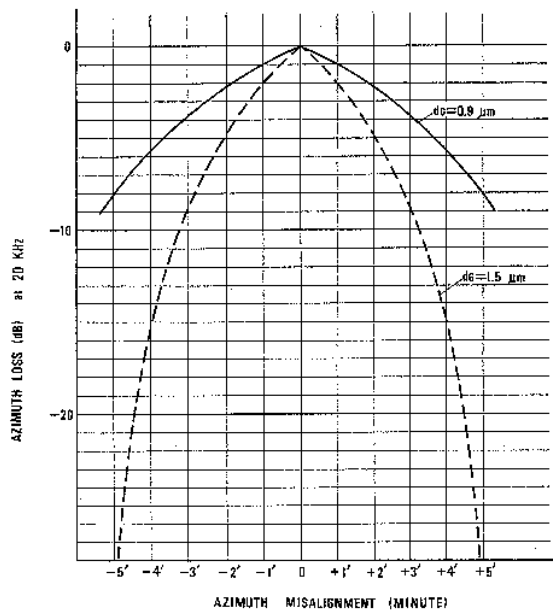

Fig. 2.1.2 Azimuth Misalignment vs Azimuth Loss (Playback Output Loss) at 20 kHz

heads and tape guide are placed in the most appropriate positions. The following describes the details of the 2 different improvements newly incorporated in the N-600II:

(1) SuperHead

Even if an Azimuth misalignment is noted because of tape skew, deterioration of performance has been greatly reduced upon decreasing the gap of the Record/Playback Head from 1.5 microns to 0.9 micron.

Where gap width is decided to be d , it is publicly known that the gap loss L_d is obtained by the following formula:

$$L_d = 20 \log \frac{\sin \frac{\pi d}{\lambda}}{\frac{\pi d}{\lambda}} \text{ (dB)}$$

Legend: d = Gap width of Playback head
 λ = Recording wave length ($\lambda = v/f$, v = Tape speed)

The SuperHead employs a narrower gap than the conventional heads, which resulted in decreasing loss against frequencies at highs and an improvement of frequency response.

Where there should be any azimuth misalignment, it would equivalently converted to gap loss and will give affect to frequency response. Fig. 2.1.1 shows Equivalent Gap Width, Fig. 2.1.2 azimuth misalignment at frequency of 20 kHz vs azimuth loss (playback output loss) when gap width is considered to be a parameter, and Fig. 2.1.3 shows frequency vs azimuth loss when azimuth misalignment is considered to be a parameter.

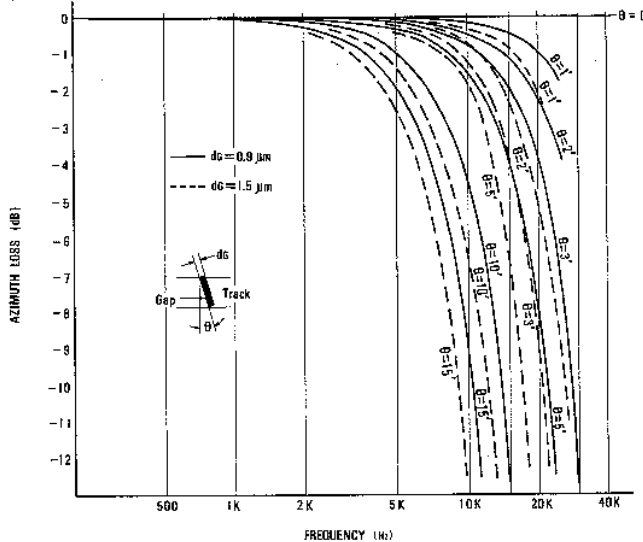

Fig. 2.1.3 Frequency vs Azimuth Loss

(2) Headblock

Although the N-600II is of 2-head cassette system, the entire head adjustment functions are incorporated in the head plate assembly as can be noted with the 3-head cassette systems produced by Nakamichi Research Inc., and each of the adjustments can be performed individually without giving effect to another adjustment. See Fig. 2.1.4.

a. Adjustment of Tape Guide Height:

One side of the erase head is firmly fixed, whereas the other side can be adjusted with an adjustment screw. The adjustment screw is placed on a spring, and therefore either tightening or loosening it will make it possible to adjust the height of the tape guide. The tape guide of the record/playback head consists of a part of the head plate and can be adjusted separately from the record/playback head. Adjustment is conducted by means of a Tape Guide Adjuster B Jig (0D09011A).

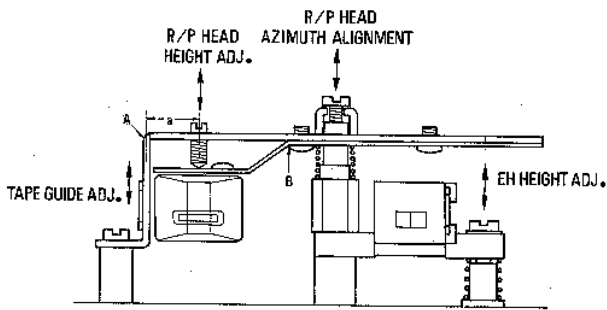

Fig. 2.1.4 Head Housing

b. Adjustment for Record/Playback Head Height and Azimuth:

The Record/Playback Head is fitted to a steel plate spring from head plate ass'y, and its height is adjusted with a head height adjustment screw.

While adjusting Record/Playback Head, Azimuth will change when height is adjusted, whereas height will change when azimuth is adjusted, as a result of which adjustment of both height and azimuth will have to be repeated.

Incorporated in the N-600II therefore is a function with which azimuth can stay stabilized even though the head height is adjusted.

Figs. 2.1.5 and 2.1.6 show the representative azimuth changes when head height is adjusted, and changes of height when azimuth is adjusted together with the pertinent formulas.

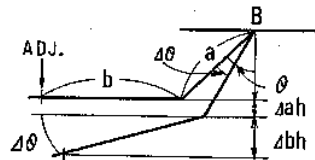

Fig. 2.1.5 Azimuth Changes

$$\begin{aligned} \Delta ah &= \text{acos}(\theta - \Delta\theta) - \text{acos}\theta \\ &\approx \text{asin}\theta \cdot \Delta\theta \\ \Delta bh &= b\text{sin}\theta \approx b\Delta\theta \\ (\text{If } \Delta\theta \text{ is very small}) \\ \Delta h &= \Delta ah + \Delta bh \\ &= (\text{asin}\theta + b) \Delta\theta \end{aligned}$$

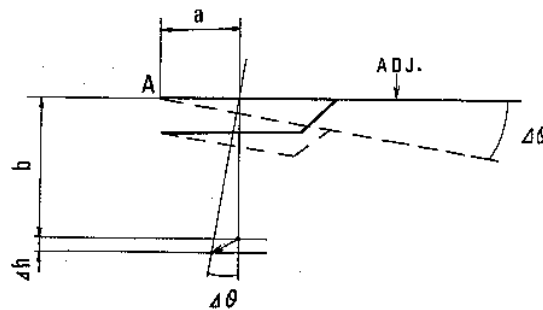

Fig. 2.1.6 Height Changes

$$\begin{aligned} \Delta h &= (\text{asin}\Delta\theta + b\text{cos}\Delta\theta) - b \\ &= \text{asin}\Delta\theta + b(\text{cos}\theta - 1) \\ (\text{If } \Delta\theta \text{ is very small; } \text{sin}\Delta\theta \approx \Delta\theta, \text{cos}\Delta\theta \approx 1) \\ \Delta h &= a\Delta\theta \end{aligned}$$

2.2 Playback Eq. Amp. Circuit

Fig. 2.2.1 shows the playback equalizer circuit, and Fig. 2.2.2 is its system diagram. Fig. 2.2.3 shows the time constant of equalizer. The playback head is connected with circuit's input.

Amplifier 1 (Q101 and Q102) is an equalizer amplifier and its time constant is illustrated in Fig. 2.2.3.

R,L,C1 and C2 compose of a peaking circuit. This circuit compensates the air gap loss of the playback head so that high-frequency response may be improved.

Phase shifter acts to compensate the phase delay characteristics of the frequency response. Phase delay characteristics are improved within 30 degrees up to 10 kHz. Therefore modulation for the complex wave will reduce. Playback Eq. Amp. gain is adjusted by semi-fixed volume VR101 (Amp. 2—Q104, 105) to obtain 580 mV output level when 400 Hz Level Tape (DA09005A) is being played back.

Equalizer switch (70 μs/120 μs) is connected with Amp 2. The overall time constants in Playback Eq. Amp. are as follows:

- Eq. SW — 70 μs
3180 μs (50 Hz) + 70 μs (2274 Hz)
- Eq. SW — 120 μs
3180 μs (50 Hz) + 120 μs (1326 Hz)

Shown below is the table for the position of tape switch and Eq. switch:

Tape SW	Eq. SW	Tape
SX	70 μs	Nakamichi SX, TDK SA Maxell UDXL-II Scotch Master 70 μs
EX	120 μs	Low-Noise High-Density (including EX, EXII TDK AD, Maxell UDXL-I Scotch Master 120 μs)
EX	70 μs	Nakamichi EX, EXII

When 70 μs is selected at EX tape position, signal to noise ratio will be improved by 4.7 dB (WTD).

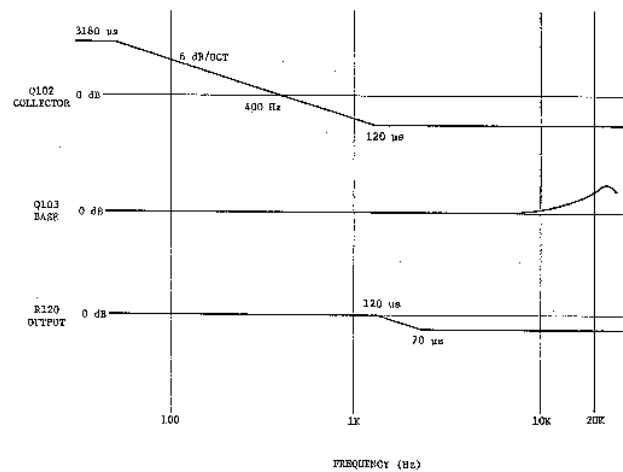

Fig. 2.2.3 Playback Eq. Amp. Time Constant

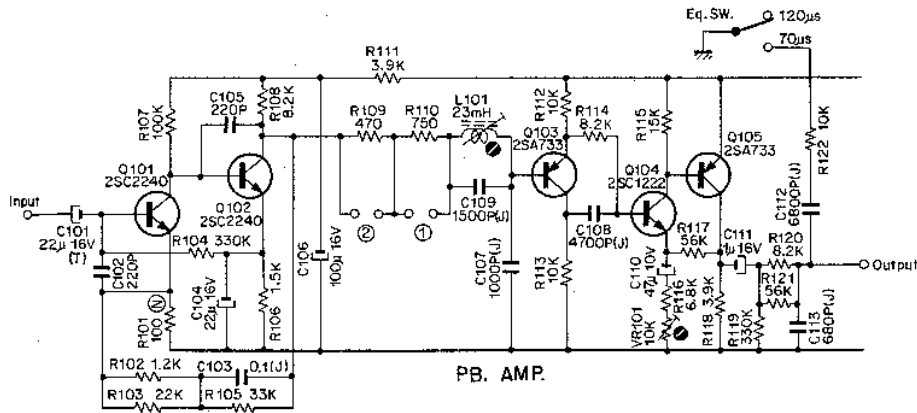

Fig. 2.2.1 Playback Eq. Amp. Circuit

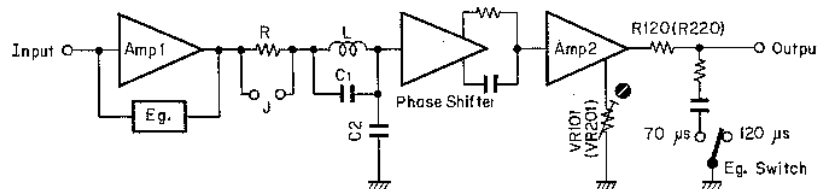

Fig. 2.2.2 Playback Eq. Amp. System Diagram

2.3. Test Tone Circuit

By means of the Ope-Amp. IC, the N-600II oscillates 2 kinds of tones, that are 400 Hz (0 dB) for record level calibration and 10 kHz (-8 dB) for bias calibration.

As shown in Fig. 2.3.1, the Test Tone consists of oscillation portion through IC4558 and band pass filter comprising either of 400 Hz or 10 kHz, and either of 400 Hz or 10 kHz can be selected by the Test Tone Frequency Switch. Power will be supplied to the Test Tone Circuit in Record mode and will be made only while the Test Tone Switch is set to ON.

The circuit also contains a lamp circuit preventing erroneous adjustment as may occur while in bias calibration or record level calibration, and each of the said lamps will be lit as follows depending upon the conditions of the Test Tone Frequency Switch and Tape Switch:

- S1: Test Tone Frequency Switch (400 Hz/10 kHz)
- S2: Tape Switch (EX/SX)
- S1 (400 Hz). S2 (EX) – Rec. Cal. EX Lamp ON
- S1 (400 Hz). S2 (SX) – Rec. Cal. SX Lamp ON
- S1 (10 kHz). S2 (EX) – Bias Adj. EX Lamp ON
- S1 (10 kHz). S2 (SX) – Bias Adj. SX Lamp ON

Power will be supplied to each of the Lamps through the Tape Switch, and the Lamps are connected to GND by way of the Test Tone Frequency Switch and Inverter Q305 activated by the said Switch.

IC301-1/2 consists of oscillation function, feeds its output back to input and oscillated square wave up to power source voltage level so that the oscillation voltage can be stabilized. A capacitor is connected to No. 6 terminal of the IC301-1/2 for the convenience while changing over one frequency to another. (400 Hz: 0.0178 μ F, 10 kHz: 620 pF)

Band pass filter is created between IC301-1/2 and 2/2, and the sine wave of the selected frequency will be obtained at the output terminal 1 of the 2/2.

With regard to band pass filter curve, please refer to Fig. 2.3.2.

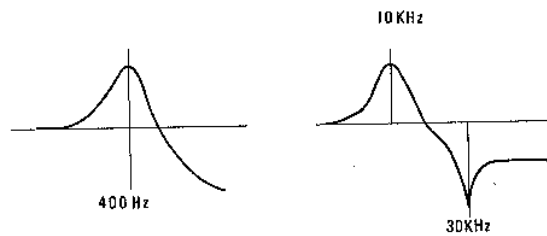

Fig. 2.3.2

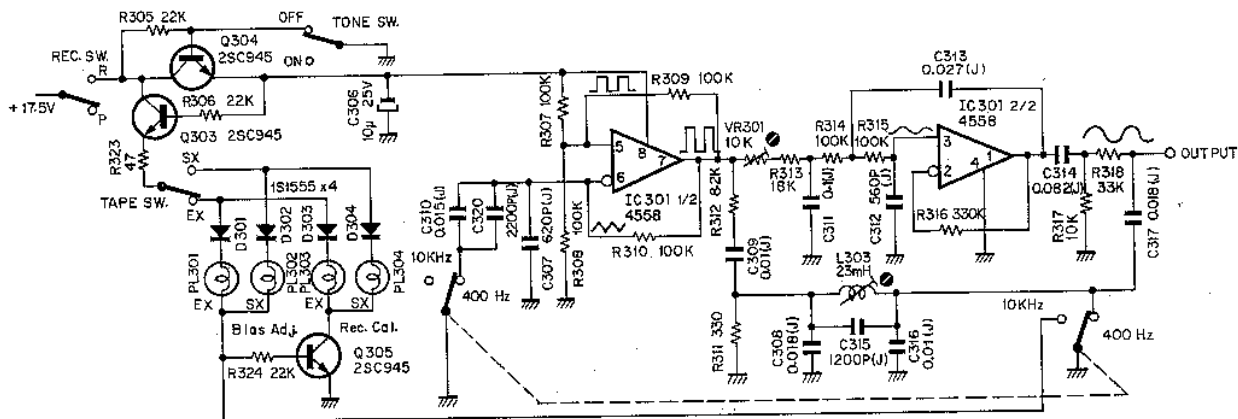

Fig. 2.3.1 Test Tone Circuit

2.4 Bias Osc. Circuit

Fig. 2.4, shows a push-pull oscillator with an oscillation frequency of 105 kHz which is constructed by capacitors C302 and C303 decoupling the collectors and bases of two transistors (Q301 and Q302).

This is used to provide recording bias and as an erase signal. By depressing the record button, the bias oscillator power supply is activated and oscillation begins. When the record mode is released, oscillator output is damped by the discharge of C304. This prevents magnetization of the head.

In the conventional oscillation circuit, the bias adjustment for SX and EX has been conducted only at the output side of the Bias Osc., which is also applied to N-600II but plus variation of the voltage to be fed to the oscillation

circuit. In normal adjustments, the Bias Adjustment Controls fitted with a center lock is first set to center (100 ohms) and is managed to correspond to each of the tape with a bias calibration semi-fixed volume. Under such state, setting the control with center lock to 0 – 200 ohms will vary the voltage to be applied to the Bias Osc., thereby bias control is carried out.

Where another different tape is used, bias current can be varied approximately by $\pm 10\%$, which can therefore be applied to a certain variety of different tapes through only the adjustment of the Bias Adjustment Control (there would be approximately ± 2 dB difference of level between maximum and minimum at 20 kHz against center (0dB)).

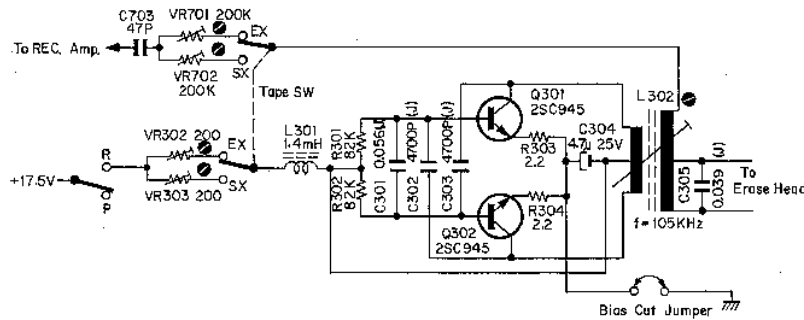

Fig. 2.4 Bias Osc. Circuit

2.5. Unattended Record or Playback, and Shut-off Circuit

2.5.1. Unattended Record or Playback

- (1) Depress the record button then depress the play button (depress only the play button for unattended playback).
- (2) Depress the pause button.
- (3) Turn OFF the external power source.
- (4) When external power turns ON, approximately 4 seconds later, the transport will automatically release itself from the pause mode and begin to record (or play).

2.5.2. Shut-off Circuit

Fig. 2.5.2 and 2.5.3 show the shut-off circuit and timing chart. Fig. 2.5.1 shows the flow chart for the shut-off function.

Following are explanations according to the order of the flow chart Nos.:

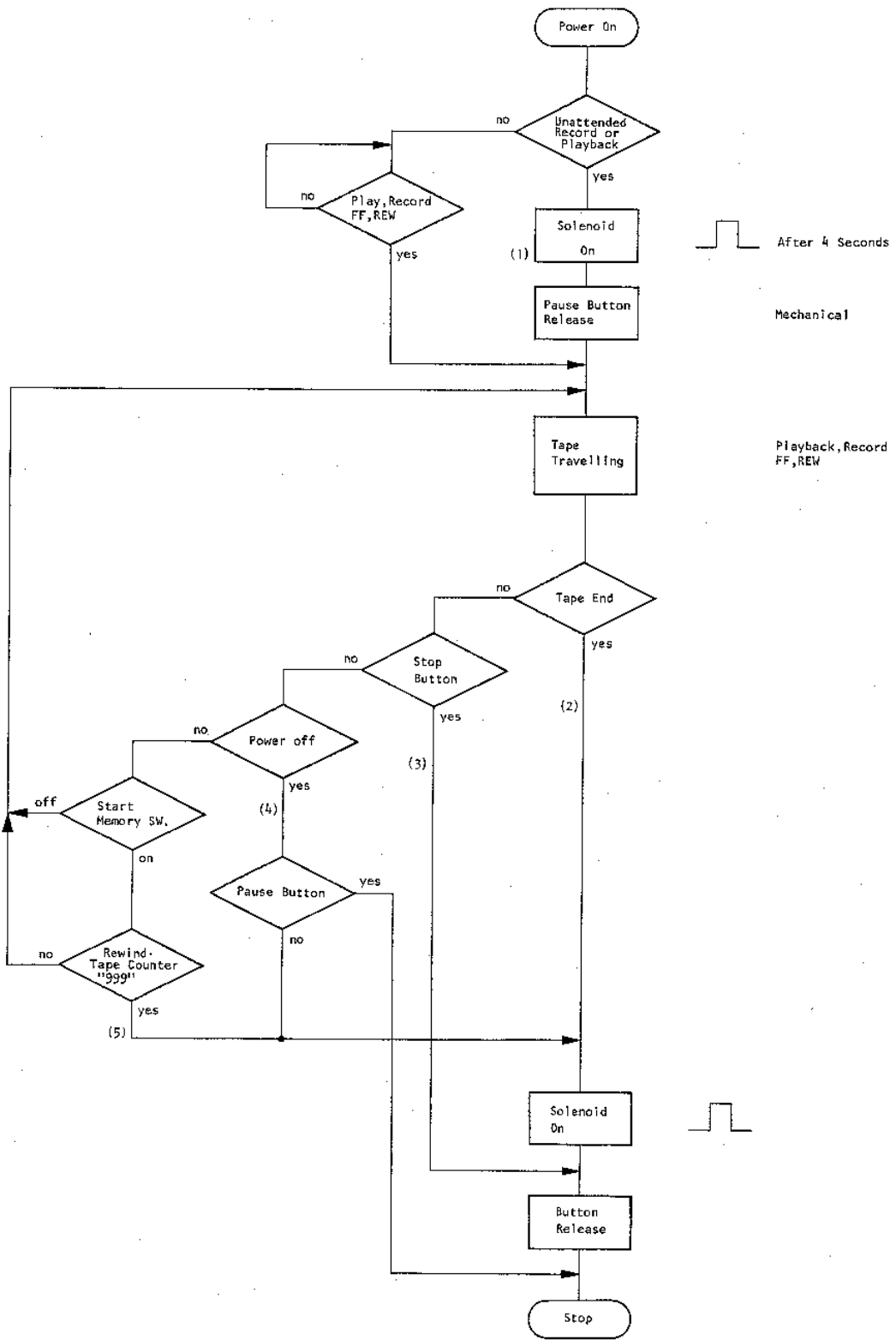

Fig. 2.5.1 Shut-off Flow Chart

(1) External Power ON

When external power is turned ON at attended record or playback mode, transistor Q606 turns to ON approximately 4 seconds later. By the Q606 ON, differentiated positive pulse is added to the Q602 base through capacitor C607.

Then Q602 turns to ON and Q601 base current flows. Q601 turns to ON and base current of the Q602 is supplied through Q601.

Namely Q602 and Q601 construct a memory circuit and triggered by a pulse applied to Q602 base.

When Q601 turns to ON solenoid is driven by the discharge of C606 (2200 μ F).

As the resistance of the solenoid is about 12-ohm, C606 is discharged quickly, though C606 is charged through resistor R615 (470-ohm).

About 70 msec after, the voltage of Q601 collector becomes less than about 1.2 V, then enough base current does not flow to the Q602, and Q602 turns to OFF subsequently Q601 turns to OFF.

C606 starts charging again preparing for the next solenoid drive.

From the above, solenoid works as a pulse motion and driven solenoid performs shut-off and releases the pause button.

(2) Tape End

Counter pulley linked to a take-up reel turns and switches a Hall IC ON/OFF repeatedly.

At a tape end, pulley stops and the Hall IC ON/OFF operation stops. Therefore the discharge of the C604 through Q604 (synchronizing with the periodic Hall IC ON/OFF) stops. Then C604 starts charging, and when the voltage across C604 exceeds about 4.5 V, Q603 turns to ON and Q601 turns to ON.

The principle how to drive the solenoid is the same as preceding item (1).

Solenoid acts to release the play, record, FF and REW buttons.

Therefore start switch opens and no power supply (+ 18 V) is applied to the shut-off P.C.B. ass'y and motor.

Note: In the Models bearing serial Nos. A206.7 05000 and smaller, a reed switch is incorporated instead of a Hall IC. One magnet is mounted in the counter pulley and 2 pulses are generated for one rotation.

Hall IC operates on alternative magnetic fields. 4 pulses are generated for one counter pulley rotation. Hall IC provides the following improvements:

- a. Quick response of shut-off.
- b. No mechanical noise from IC, as the Hall IC has no moving elements.

(3) Stop Button Depressing

When stop button is depressed play, record, FF and REW buttons are released mechanically.

(4) Power OFF

DC power supply (+ 18 V) will discharge by the power switch OFF.

Since the discharge time constant of the C606 is great, the voltage of the Q605 base (i.e. + 18 V) becomes low with respect to the emitter.

Therefore Q605 turns to ON, Q603 turns to ON and then Q601 turns to ON. Solenoid is driven and control buttons are released.

In case pause button is depressed, solenoid does not work because Q603 base is connected to ground through pause button, and no control button is released. Thus unattended record or playback is possible.

(5) Memory Rewind

When the tape counter reaches "999" counter switch closes. At memory switch ON in rewind mode, the differentiated negative trigger pulse is added to the Q601 base and Q601 turns to ON. And solenoid is driven.

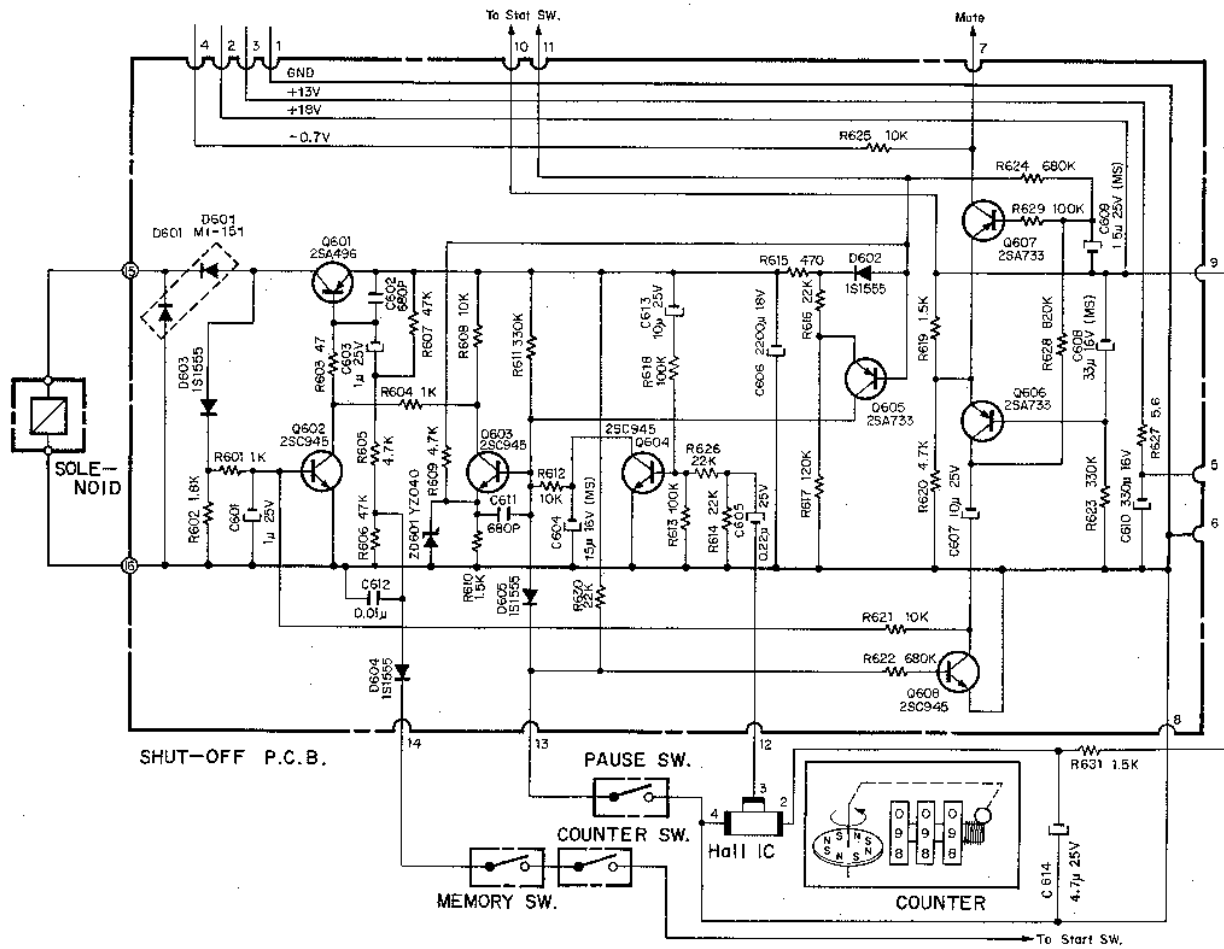

Fig. 2.5.2 Shut-off Circuit

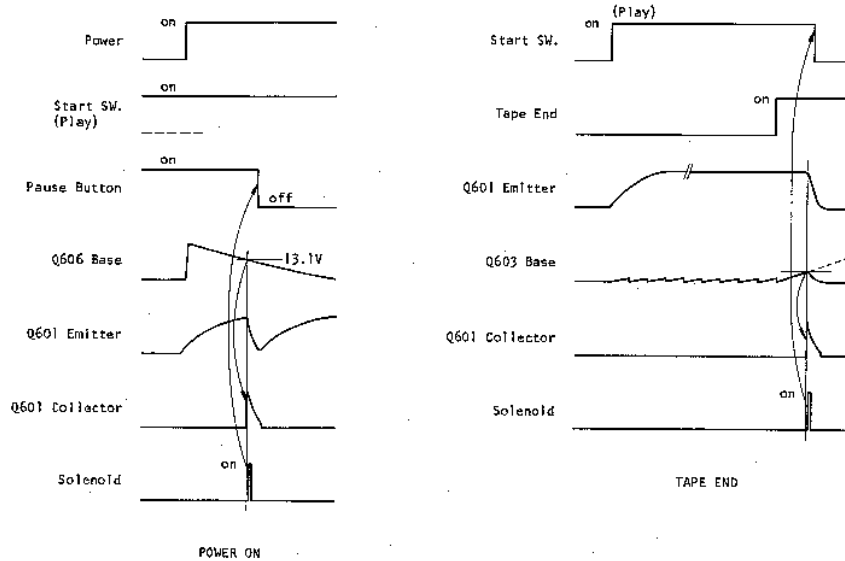

Fig. 2.5.3 Shut-off Timing Chart

3. REMOVAL PROCEDURES

3.1. Cassette Lid Plate

Refer to Fig. 3.1. Depress the eject button to open cassette case ass'y, then remove F01 (cassette lid plate).

3.2. Cabinet

Refer to Fig. 3.2. Remove F01 (5 places) and F02 (cabinet).

3.3. Volume Cap

Refer to Fig. 3.2. Remove F03 through F05.

3.4. Handle Ass'y

Refer to Fig. 3.2. Remove F06 (4 places) and F07 (handle ass'y).

3.5. Front Panel Ass'y

Refer to Fig. 3.2. Remove F08 (front panel ass'y).

3.6. Mechanism Ass'y

Refer to Fig. 3.3. Remove front panel ass'y referring to above items 3.1 through 3.5. Remove F01 through F03 and F04 (mechanism ass'y).

3.7. Front Control Ass'y

Refer to Fig. 3.3. Remove front panel ass'y referring to item 3.5. Remove F05 and F06 (front control ass'y).

3.8. Volume P.C.B. Ass'y

Refer to Fig.3.3. Remove front panel ass'y referring to item 3.5. Remove F07 through F09 (volume P.C.B. ass'y).

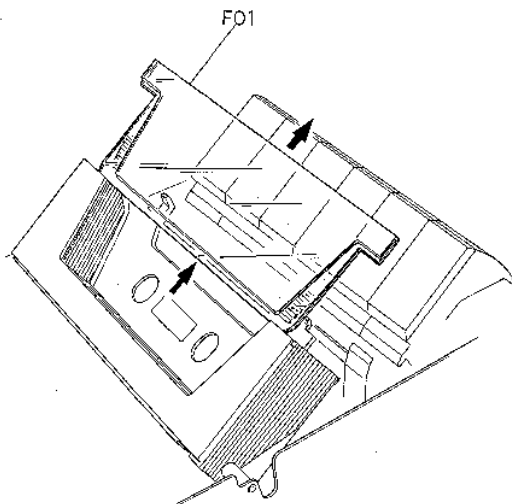

Fig. 3.1

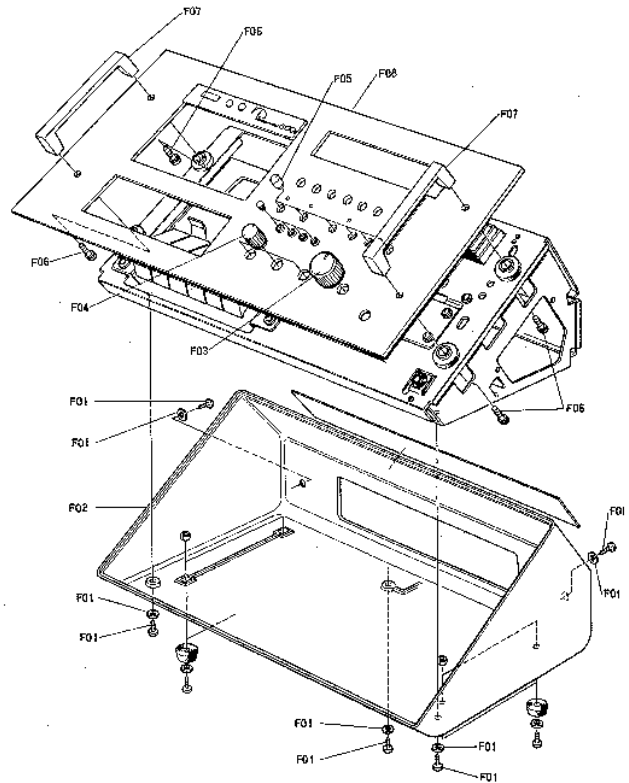

Fig. 3.2

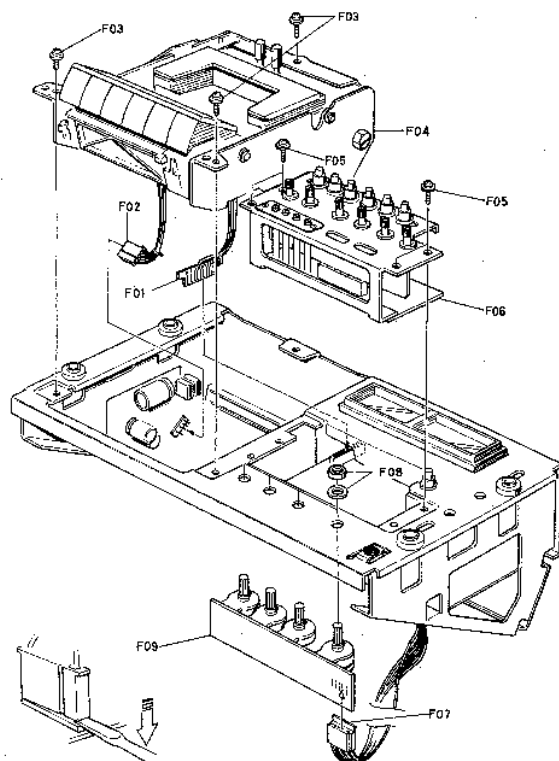

Fig. 3.3

3.9. Record/Playback Head Ass'y, Erase Head and Pressure Roller Ass'y

Refer to Fig. 3.4. Remove front panel ass'y referring to item 3.5.

- (1) Pressure Roller Ass'y
Remove F01 then pressure roller ass'y.
- (2) Record/Playback Head Ass'y
Remove F02 through F04 then record/playback head ass'y.
- (3) Erase Head
Remove F05 through F08 then erase head.

Note: When record/playback head is replaced, twist signal wires (red and white) which are soldered to head terminals for reducing the interference of hum.

3.10. Cassette Case Ass'y

Refer to Fig. 3.5. Remove mechanism ass'y referring to item 3.6. Remove F01 through F07.

Note: Remove F04 and F05 by pincers with care.

3.11. Cassette Lid Ass'y

Refer to Fig. 3.5. Remove cassette case ass'y referring to item 3.10. Remove F08 through F12.

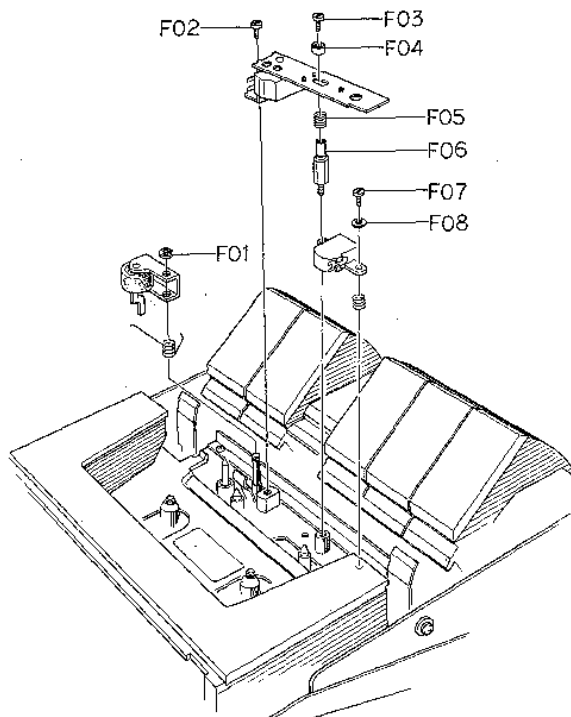

Fig. 3.4

3.12. Control Button Ass'y

Refer to Fig. 3.6. Remove mechanism ass'y referring to item 3.6. Remove F01 through F05, then control button ass'y.

Note: Following are assembled in pair.
F06-F07, F08-F09, F10-F11, F13-F14, F15-F16

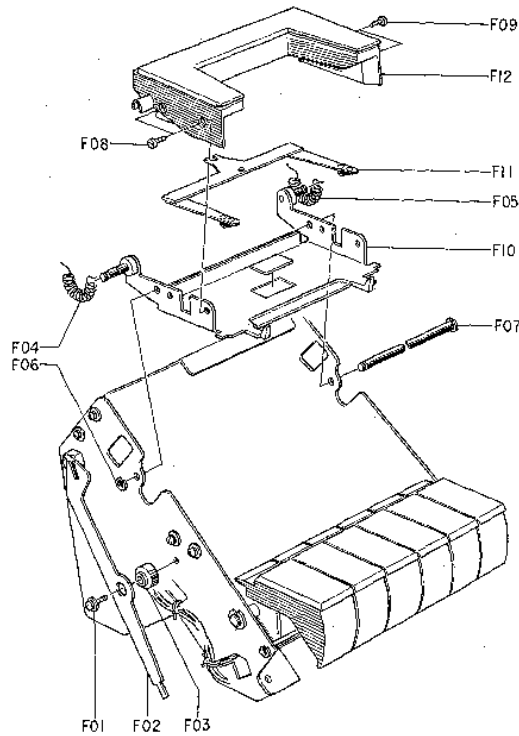

Fig. 3.5

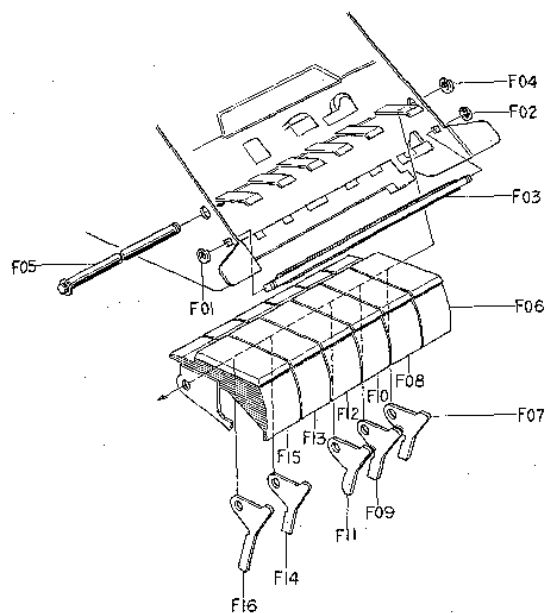

Fig. 3.6

3.13. Counter Holder Ass'y

(1) Hall IC System

Refer to Fig. 3.7. Remove front panel ass'y referring to item 3.5. Remove F01 through F04, then counter ass'y, memory switch and hall IC P.C.B. ass'y.

(2) Reed Switch System

Refer to Fig. 3.8. Remove front panel ass'y referring to item 3.5. Remove F01 through F06, then counter ass'y, memory switch and reed switch.

Note: The leads of reed switch shall not be in contact with the chassis.

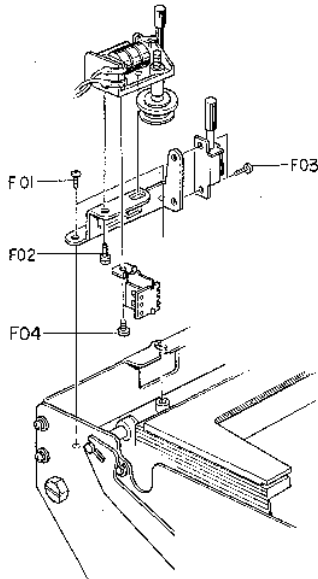

Fig. 3.7 Serial No. A206.7 05001 and greater

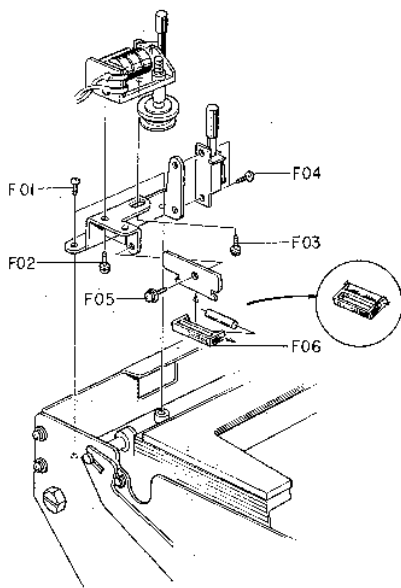

Fig. 3.8 Up to serial No. A206.7 05000

3.14. Reel Hub Ass'y (Supply, Take-up)

Refer to Fig. 3.9. Remove Cassette case ass'y referring to item 3.10. Remove F01 and F02, then supply and take-up reel hub assemblies.

3.15. Shield Cover, Motor and Motor Governor

Refer to Fig. 3.10. Remove mechanism ass'y referring to item 3.6. Remove F01 through F03 (shield cover) and F04 through F06 (motor governor). Dismount F07 and F08, and lift motor, and then remove F09 and F10. Loosen F11 and remove F12 and motor.

Note: Readjustment of belt travelling, tape speed and wow/flutter will be required.

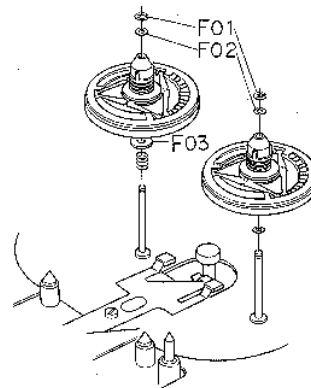

Fig. 3.9

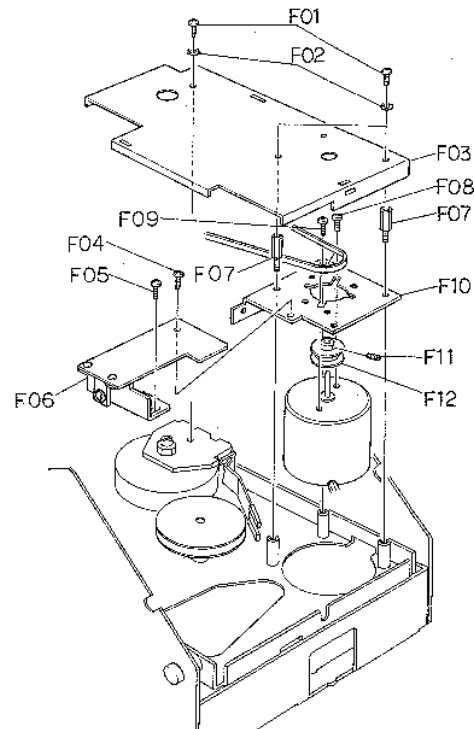

Fig. 3.10

3.16. Flywheel Ass'y

Refer to Fig. 3.11. Remove mechanism ass'y referring to item 3.6. Remove F01 through F05, F06 (flywheel ass'y) and F07.

Note: Readjust the clearance between flywheel and flywheel holder. Check on belt travelling, tape speed and wow/flutter will be required.

3.17. Idler Pulley Ass'y

Refer to Fig. 3.11. Remove flywheel ass'y referring to item 3.16. Remove F08 and F09 (idler pulley ass'y).

Note: Readjust the brake timing. Check on belt travelling, tape speed and wow/flutter will be required.

3.18. Main P.C.B. Ass'y

Refer to Fig. 3.12. Remove front control ass'y referring to item 3.7. Remove F01 through F04, then F05 (main P.C.B. ass'y).

3.19. Dolby NR P.C.B. Ass'y

Refer to Fig. 3.12. Remove main P.C.B. ass'y referring to item 3.18. Unplug F06 (Dolby NR P.C.B. ass'y) from main P.C.B. ass'y.

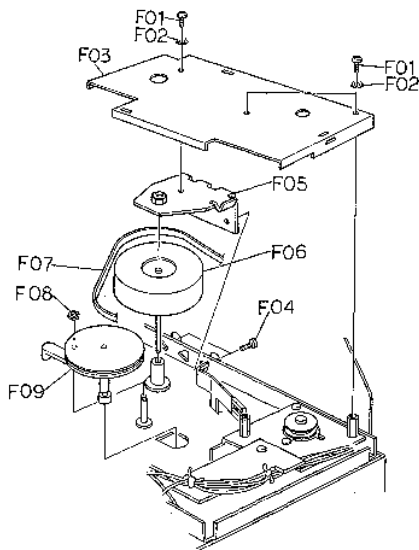

Fig. 3.11

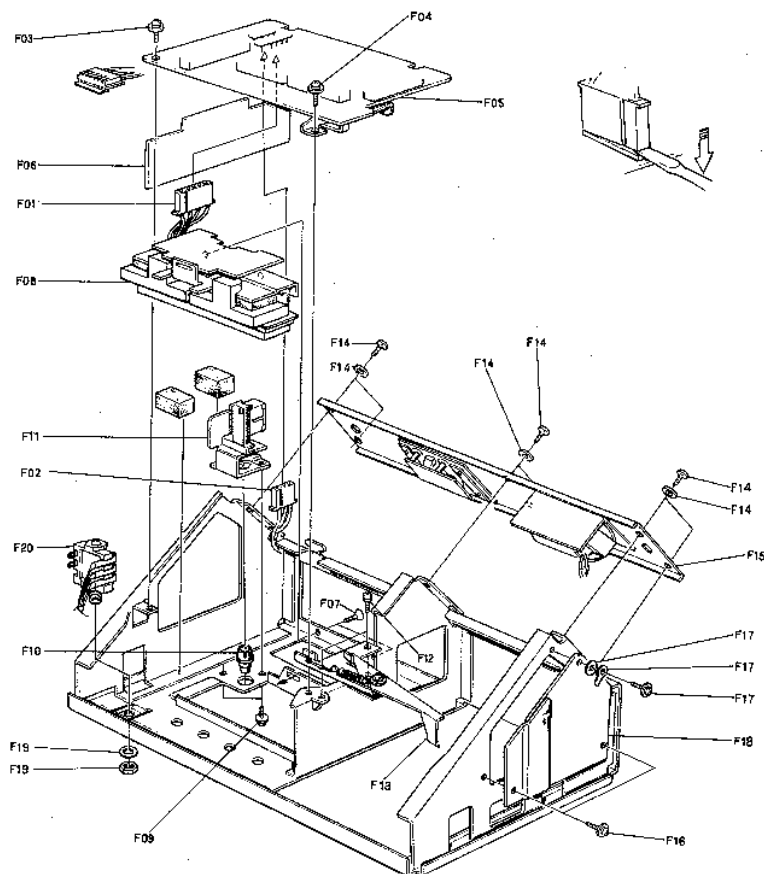

Fig. 3.12

3.20. Meter Ass'y

Refer to Fig. 3.12. Remove front panel ass'y referring to item 3.5. Remove F07 and F08 (meter ass'y)

3.21. Power Switch Ass'y

Refer to Fig. 3.12. Remove main P.C.B. ass'y referring to item 3.18. Remove F09 through F11 (power switch ass'y)

3.22. Record Link Ass'y

Refer to Fig. 3.12. Remove main P.C.B. ass'y referring to item 3.18. Remove F12 and F13 (record link ass'y).

3.23. Rear Panel Ass'y

Refer to Fig. 3.12. Remove cabinet referring to item 3.1. Remove F14 and F15 (rear panel ass'y).

3.24. Power Supply P.C.B. Ass'y

Refer to Fig. 3.12. Remove cabinet referring to item 3.1. Remove F16 through F18 (power supply P.C.B. ass'y).

3.25. Headphone Jack

Refer to Fig. 3.12. Remove cabinet referring to item 3.1. Remove F19 and F20 (headphone jack).

4. MEASUREMENT AND MAINTENANCE INSTRUMENT

Note: Refer to item 3 "Removal Procedures".
When a check is made on Amp., etc. by means of an extension cord, re-adjustment shall be made without fail after final installation to the model chassis. The check without removal of an extension cord will cause inaccurate adjustments.

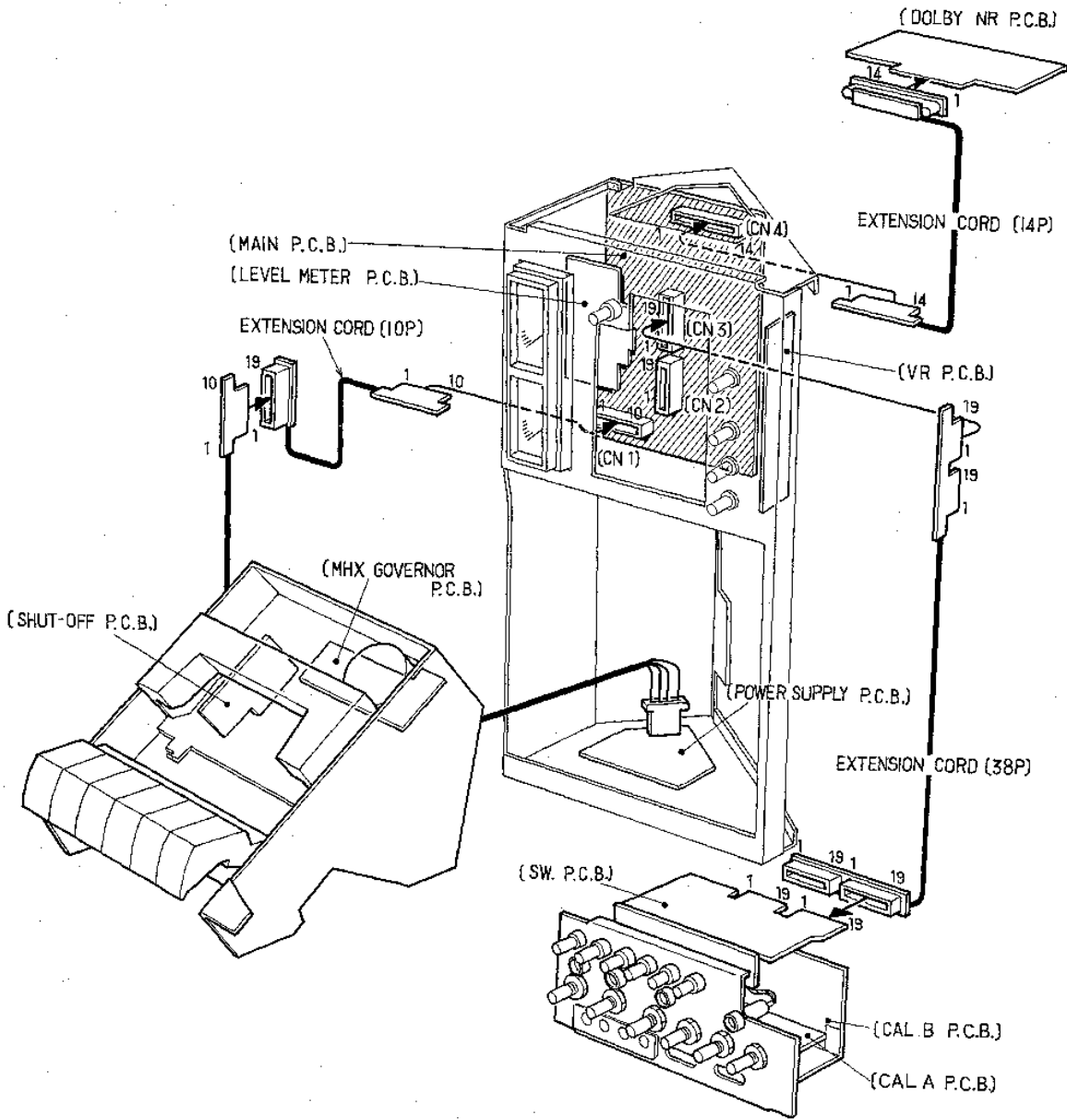

PERSPECTIVE VIEW

Fig. 4 Extension Cord Connection

5. MECHANICAL ADJUSTMENTS

4.1. Measurement Instrument

- (1) Audio Generator (20 Hz – 200 kHz)
- (2) AC Millivolt Meter (with dB measures)
- (3) Oscilloscope (DC – 5 MHz)
- (4) Distortion Meter
- (5) Speed & Wow/Flutter Meter
- (6) Frequency Counter (DC – 1 MHz)
- (7) Ohm Meter
- (8) DC Volt Meter
- (9) AC Volt Meter
- (10) Tape Travelling Cassette B (part No. DA09027A)
- (11) Torque Gauge (DA09013A)
- (12) 15 kHz Azimuth Tape (DA09004A)
- (13) 3 kHz Speed & Wow/Flutter Tape (DA09006A)
- (14) 1 kHz Track Alignment Tape (DA09007A)
- (15) 400Hz Level Tape (DA09005A)
- (16) 20 kHz PB Frequency Response Tape (DA09001A)
- (17) 15 kHz PB Frequency Response Tape (DA09002A)
- (18) 10 kHz PB Frequency Response Tape (DA09003A)
- (19) Reference EXII Tape (DA09021A)
- (20) Reference SX Tape (DA09025A)
- (21) Track Viewer (DA09012A)
- (22) Tape Guide Adjuster B (0D09011A)
- (23) Audio Analyzer T-100
(including Distortion, Wow/Flutter, Speed, Oscillator and dB meter)
- (24) Information Terminals, Model M-300
(for positioning of record/playback head)

Note: (10) – (23) are the products of NAKAMICHI RESEARCH INC.

4.2. Maintenance Instrument

Refer to Fig. 4.1 Extension Cord Connection.

- (1) Extension cord (10p) (part No. DA09020A)
- (2) Extension cord (14p) (DA09016A)
- (3) Extension cord (38p) (DA09026B)

5.1. Take-up Torque and Rewind Torque Adjustment

To adjust torque, move reel hub spring as shown in Fig. 5.1. The take-up torque should be 45 ± 10 g-cm and rewind torque should be 35 to 60 g-cm.

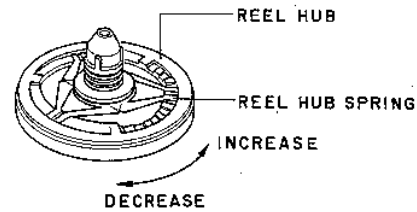

Fig. 5.1

5.2. Tape Speed Adjustment

- (1) Connect a frequency counter to the output jack.
- (2) Load a 3 kHz Speed Wow/Flutter Tape (DA09006A) and play it back.
- (3) Adjust the tape speed adjust potentiometer (accessible from the rear apron without removing cabinet).
See Fig. 5.2.

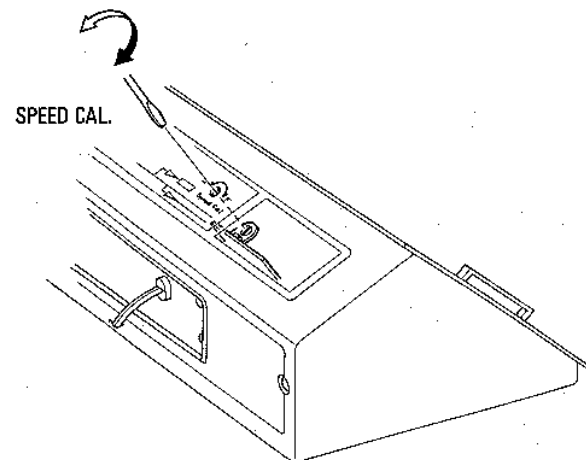

Fig. 5.2

5.3. Headblock Adjustment

5.3.1. Adjustment of Tape Guide Height (Erase, Record/Playback)

Referring to Fig. 5.3.1 and with use of an M-300 produced by Information Terminals, adjustments of height of the tape guides for Erase and Record/Playback Heads shall be made, wherein a small block shall be pushed straight down to the base while in use of the M-300.

- (1) Adjustment of Erase Head Guide Height
Depress the play button. Place the small block of the M-300 on the guide for Erase Head, then referring to Fig. 5.3.3, turn the Head Height Adjustment Screw so that the small block will come into the groove of the Head Guide.
- (2) Adjustment of Record/Playback Head Guide Height
Depress the play button. Place the small block of the M-300 on the guide for Record/Playback Head, and then referring to Fig. 5.3.2, lead the Tape Guide Adjuster B into the adjustment groove, and adjust the said adjuster so that the small block will become accepted by the groove between the guide's projections.

After completion of the above adjustments, apply a quantity of AVDEL BOND #114 to the gap "A" between the azimuth plate and tape guide, and clean off overflow if any.

5.3.2. Record/Playback Head Height Adjustment and Azimuth Alignment

- (1) Load a Track Viewer (DA09012A) and then visual check shall be made on the head height. Turn the Head Height Screw as shown in Fig. 5.3.3 until the center between the L and R of the Head becomes on the middle point of the 2 parallel lines (0.3 mm) of the Track Viewer. Azimuth shall also be checked visually.
- (2) Connect VTVM to Output Jacks.
- (3) Load a 1 kHz Track Alignment Tape (DA09007A). Turn the Head Height Adjustment Screw until the output of the both channels becomes minimum.
- (4) Load a 15 kHz Azimuth Tape (DA09004A). Turn the Head Azimuth Adjustment Screw until the output of both channels becomes maximum.
- (5) As the height will vary because of the adjustment as per item (4), the adjustments of items (3) shall be repeated for 2 - 3 times so that the best location can be discovered. After completion of the above adjustment, apply a quantity of AVDEL BOND #114 to the Head Height Adjustment Screw, and then clean off overflow if any.

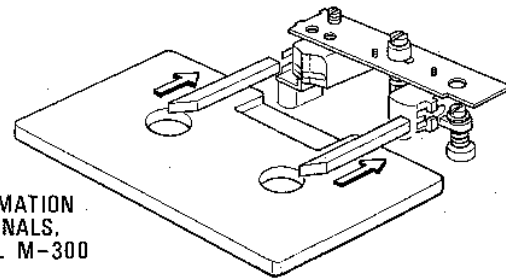

Fig. 5.3.1

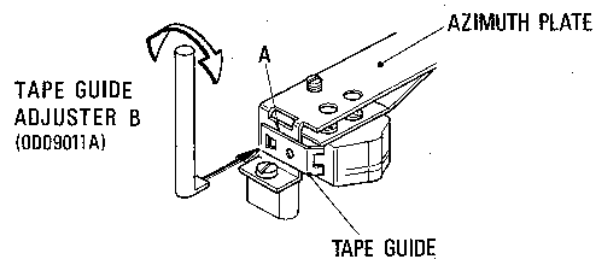

Fig. 5.3.2

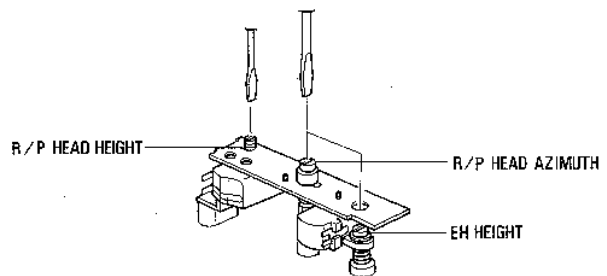

Fig. 5.3.3

5.4. Head Base Stroke Adjustment

- (1) Remove the mechanism ass'y referring to item 3.6, mechanism ass'y removal procedure.
- (2) Adjust the height of head base stroke adjustment plate as illustrated in Fig. 5.4 (Height Adj.).
- (3) Load the "INFORMATION TERMINALS M-300" jig for positioning the record/playback head, pushing it backward to eliminate the clearance between reference pin and jig.
- (4) Depress the play button and check to insure whether the positioning of the head is within the specified tolerance. If not, adjust the head base stroke adjustment plate from the bottom side in stop mode.

See Fig. 5.4 (Stroke Adj.).

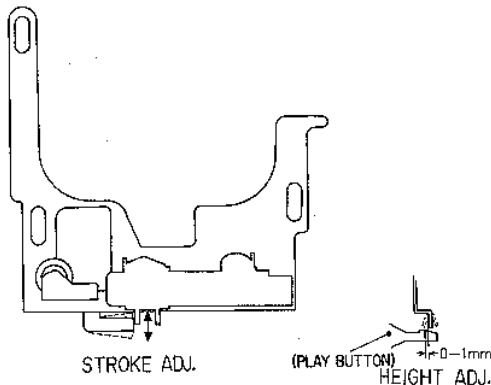

Fig. 5.4

5.5. Pause Timing Adjustment

This adjustment is required for avoiding the tape spill or tape skip by the inaccurate pause timing.

See Fig. 5.5.

- (1) Set to the playback mode without loading a cassette tape.
- (2) Depressing the pause button gradually, check to insure whether the gap between pressure roller and capstan shaft is approximately 0.1 mm when take-up pulley stops rotation because of changing mode from playback to pause.
- (3) In case above is not sufficient, remove the record link ass'y referring to item 3.22, record link ass'y removal procedure. And adjust the pressure roller as illustrated in the figure.

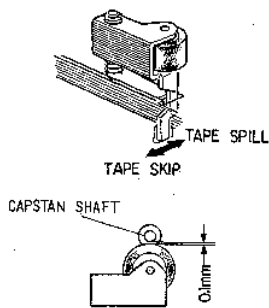

Fig. 5.5

5.6. Belt Travelling Adjustment

Refer to Fig. 5.6 and item 3.15, motor and motor governor ass'y removal procedure.

- (1) Adjust the motor pulley position and check to insure whether the drive belt is travelling along the correct position and staying at the correct position, i.e. the center part of motor pulley and the idler pulley without contacting the belt guide at the following modes:
Playback, FF, REW, FF to Stop, REW to Stop
- (2) In case motor pulley is tilting, insert spacers into the A, B (when belt slips upward on the motor pulley) or C (when belt slips downward).

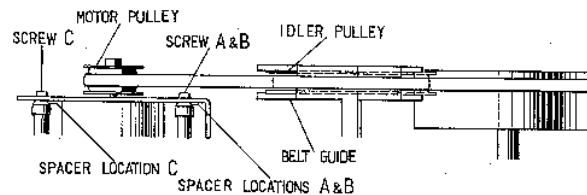

Fig. 5.6

5.7. Flywheel Adjustment

Refer to Fig. 5.7 and item 3.2, cabinet removal procedure. Adjust the flywheel clearances to be 0.05 to 0.1 mm. After adjustment is completed, lock the lock nut.

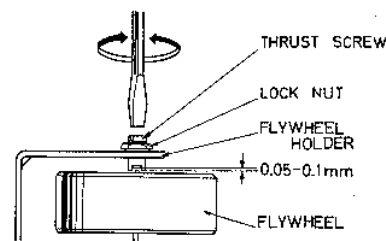

Fig. 5.7

5.8. Brake Timing Adjustment

Remove the cassette case referring to the item 3.10, cassette case ass'y removal procedure.

Refer to Fig. 5.8.

Loosen screw A, and adjust the contact point between idler pulley and brake to meet each other when control button is depressed and mode is changed from FF to Stop, REW to Stop, or Play to Stop.

Fasten screw A and check to insure the gap between idler pulley and that brake is approximately within 0.2 mm.

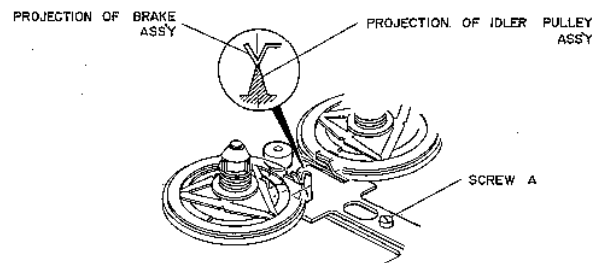

Fig. 5.8

5.9. Mute Switch and Start Switch Adjustment

See Fig. 5.9. Check the mute switch and start switch movement in the following modes.

- (1) Stop
 - Check to insure the accuracy of gaps of A and B.
- (2) Play
 - (a) Depress Start
 - Figure shows the timing when transfer 2-3 or transfer a-b opens.
 - Check to insure the accuracy of gap of C.
 - Broken line shows the position of transfer in stop mode.
 - (b) In the Course of Depress
 - Check to insure the accuracy of gap of D.
 - (c) Depress End
 - Check to insure that the transfer 4-5, 6 opens when gap E becomes more than 0.5 mm.
 - After play button is locked, check to insure the accuracy of gaps E and F.
- (3) Fast Forward
 - Depress the fast forward button and check to insure the same start switch movement as each stage of item (2) "play" as above. While in fast forward mode, mute switch does not work.
- (4) Rewind
 - (a) Depress Start
 - Figure shows the timing when transfer g-h opens.
 - Check to insure the accuracy of gap G.
 - Broken line shows the position of transfer in stop mode.

- (b) In the Course of Depress
 - Check to insure the accuracy of gap H.
- (c) Depress End
 - After rewind button is locked, check to insure the gap I.

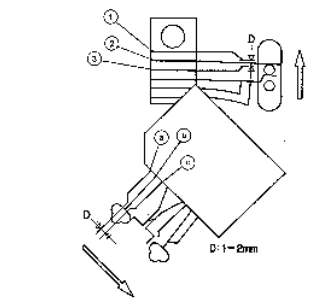
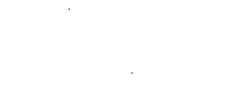
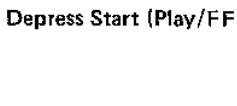
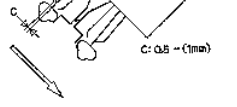
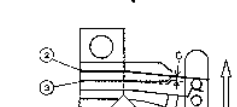
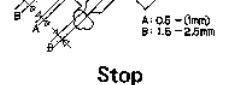
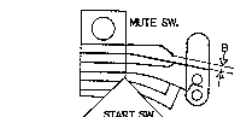
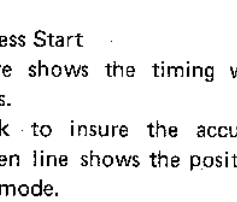
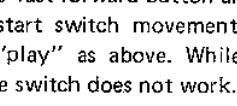
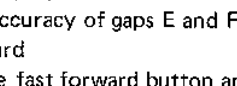
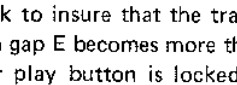
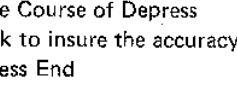
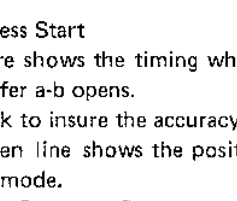

In the Course of Depress (Play/FF)

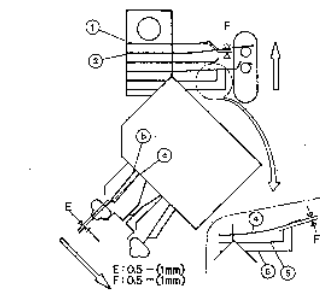

Depress End (Play/FF)

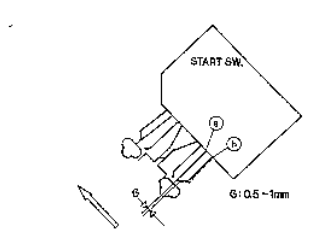

Depress Start (REW)

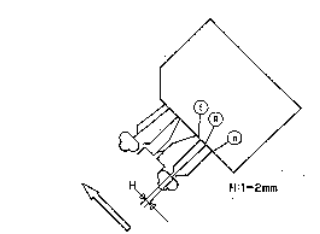

In the Course of Depress (REW)

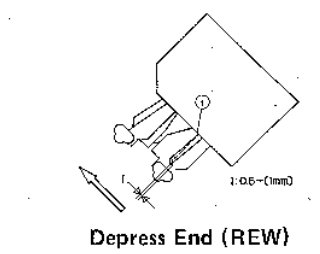

Depress End (REW)

Fig. 5.9

5.10. Solenoid Position Adjustment

- (1) Remove the mechanism ass'y referring to item 3.6, mechanism ass'y removal procedure. See Fig. 5.10.
- (2) Loosen the screw a little and move the solenoid in the A direction.
- (3) Depress the play button.
- (4) Holding the solenoid as shown in the figure, slide the solenoid gradually by a flat screwdriver in the B direction.
- (5) Then play button will release. Move the solenoid approximately 0.1 to 0.3 mm from the released point in the B direction. Fasten the solenoid.
- (6) Assemble the mechanism ass'y and turn the power switch ON. And check to insure whether the solenoid can be released at the Play, FF, REW and Pause modes.

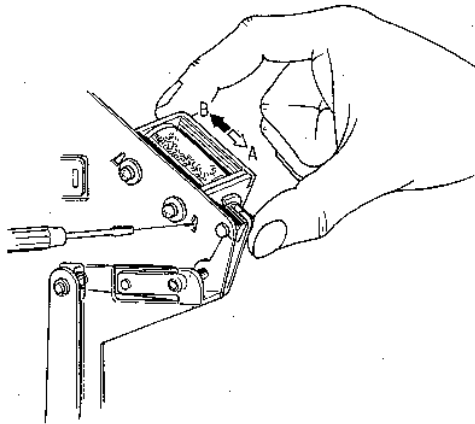

Fig. 5.10

5.11. Record Link Adjustment

Remove the cabinet referring to item 3.2, cabinet removal procedure.

Adjust the record link referring to Fig. 5.11.

5.12. Lubrication

After 500 hours of use apply a few drops of light machine oil (LAUNA No. 40) between capstan and capstan bearing. See Fig. 5.12.

After 500 hours of use apply a few drops of light machine oil (LAUNA No. 40) to the pressure roller shaft.

Note: If the lubrication oil is applied also to the capstan shaft and other drive mechanisms, clean it off with an alcohol-dipped cloth.

When flywheel or flywheel holder is replaced apply a few drops of grease to the flywheel holder.

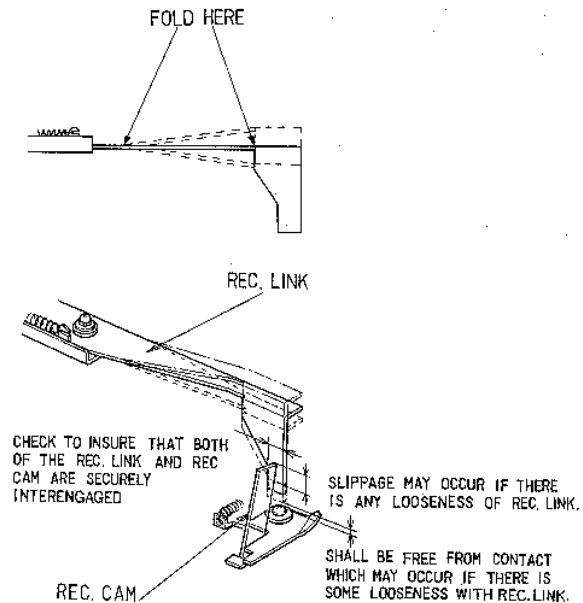

Fig. 5.11

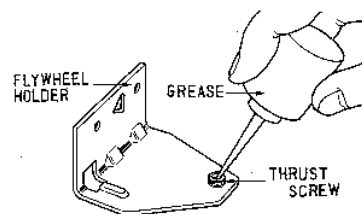
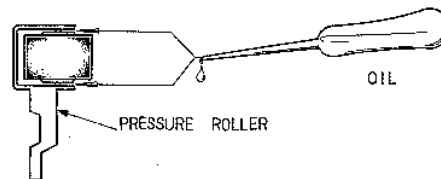
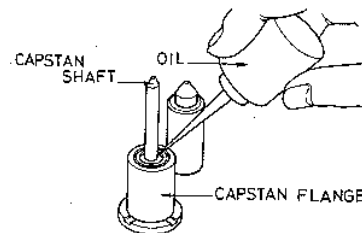

Fig. 5.12

5.13. Tape Travelling Adjustment

Load the Tape Travelling Cassette (DA09027A) and check the following:

- (1) After more than 2 seconds when depressed play button, the tolerance of the tape travelling fluctuation on the record/playback head shall not be more than 0.1 mm.
- (2) Tape is in contact with head sufficiently.
- (3) Tape waving is small (on the head and pressure roller).

If tape travelling is not good, re-adjustment of 5.1. "Take-up Torque and Rewind Torque Adjustment", 5.3. "Headblock Adjustment", 5.4. "Head Base Stroke Adjustment" and others will be required.

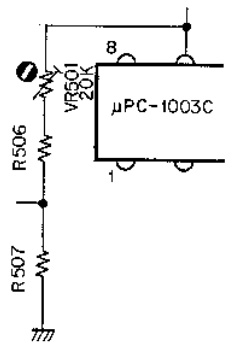

Fig. 6.1.1 Tape Speed

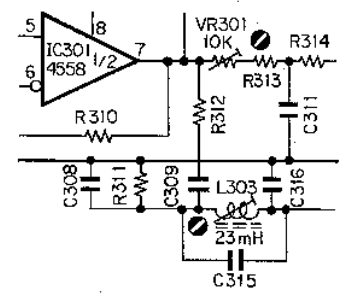

Fig. 6.1.2 Tone Calibration

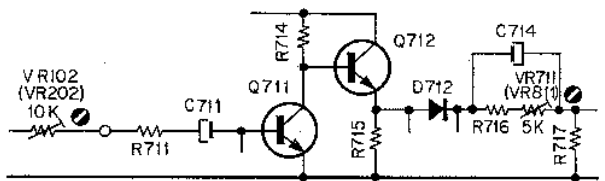

Fig. 6.1.3 Meter Level

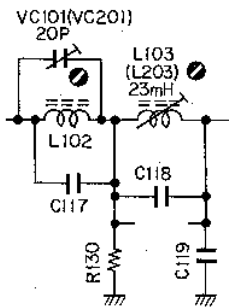

Fig. 6.1.4 MPX Filter

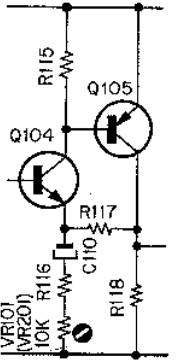

Fig. 6.1.5 Playback Level

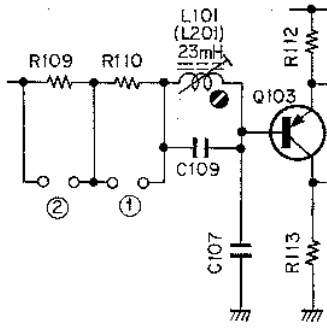

Fig. 6.1.6 Playback Frequency Response

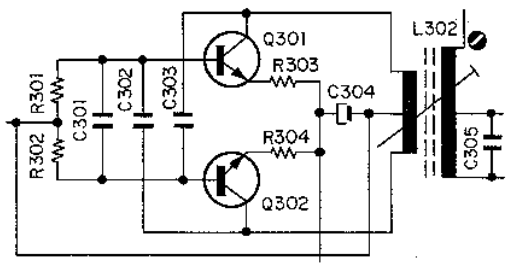

Fig. 6.1.7 Bias Osc. Frequency

6. ELECTRICAL ADJUSTMENTS AND MEASUREMENTS

6.1. Adjustment and Measurement Instructions

Refer to item 7 "Parts Location for Electrical Adjustment", wherein semi-fixed volume, test pin, etc. are shown.

STEP	ITEM	SIGNAL SOURCE	OUTPUT CONNECTION	MODE	ADJUSTMENT	REMARKS
1	Tape Speed	3 kHz Speed and Wow/Flutter Tape (DA09006A)	Frequency Counter to OUTPUT Jacks	Playback	MHX B Motor Governor P.C.B. VR501	Adjust VR501 to obtain 3 kHz \pm 1.5%.
2	Tone Calibration	Test Tone 400 Hz/10 kHz	VTVM to OUTPUT Jacks	Record, Pause Tone SW — ON Tone Freq. SW — 400 Hz/10 kHz	Main P.C.B. VR301 L303	1. Turn ON tone switch. Turn output level control fully clockwise (maximum position). 2. With test tone frequency switch to 400 Hz, adjust VR301 to obtain 580 mV \pm 0.3 dB on the VTVM. 3. With test tone frequency switch to 10 kHz, adjust L303 to obtain 231 mV \pm 0.3 dB (-8 dB against 580 mV 0 dB) on the VTVM. Note: If above is not sufficient modification of R145 or R245 on the main P.C.B. will be required.
3	Meter Level	400 Hz Test Tone or 400 Hz to Input Jacks	VTVM to OUTPUT Jacks	Record, Pause Tone SW — ON Tone Freq. SW — 400 Hz	Main P.C.B. VR102, VR202 Meter P.C.B. VR711, VR811	1. Adjust VR102 (VR202) to obtain 0 dB on the level meters at 580 mV output level on the VTVM. 2. Decrease input level by 10 dB/20 dB then adjust VR711 (VR811) to obtain minimum deviation for -10 dB/-20 dB on the level meters. (Perform at -10 dB and -20 dB.) 3. Again increase input level so that output will become 580 mV, then re-adjust VR102 (VR202) to obtain 0 dB on the level meters.
4	MPX Filter	19 kHz \pm 100 Hz to INPUT Jacks	VTVM to OUTPUT Jacks	Record, Pause MPX SW — IN	Main P.C.B. L103, L203	Adjust the coils to obtain minimum reading on the VTVM.
5	Record/Playback Head Track Alignment	1 kHz Track Alignment Tape (DA09007A)	VTVM to OUTPUT Jacks	Playback Tape SW — SX Eq. SW — 70 μ s Dolby NR SW — OUT MPX SW — OUT	Tape Guide of Record/Playback Head	Adjust the Record/Playback Head Height Screw with Tape Guide Adjuster B (0D09011A) to obtain minimum reading of both L and R channels on the VTVM. See item 5.3.2 "Record/Playback Head Height Adjustment and Azimuth Alignment".
6	Playback Head Azimuth Alignment	15 kHz Azimuth Tape (DA09004A)	VTVM to OUTPUT Jacks	Same as above	Azimuth Alignment Screw	Adjust the azimuth alignment screw to obtain maximum reading of both L and R channels on the VTVM. See item 5.3.2 "Record/Playback Head Height Adjustment and Azimuth Alignment". Note: Repeat steps 5 and 6 two or three times to obtain optimum performance.
7	Playback Level	400 Hz Level Tape (DA09005A)	VTVM to OUTPUT Jacks	Same as above	Main P.C.B. VR101, VR201	Adjust VR101 (VR201) to obtain 580 mV on the VTVM or 0 dB on the level meters.
8	Adjustment of Hum Balancer	Blank Tape	VTVM to OUTPUT Jacks	Play, Pause Eq. SW — 70 μ s Dolby NR SW — IN MPX SW — IN	Main P.C.B. Hum Balancer (Jumper Wire)	Adjust Hum Balancers to obtain minimum reading of L and R channels on the VTVM.
9	Playback Frequency Response	400 Hz Level Tape (DA09005A) 10 kHz PB Frequency Response Tape (DA09003A) 15 kHz PB Frequency Response Tape (DA09002A) 20 kHz PB Frequency Response Tape (DA09001A)	VTVM to OUTPUT Jacks	Playback Tape SW — SX Eq. SW — 70 μ s Dolby NR SW — OUT MPX SW — OUT	Main P.C.B. L101, L201	1. Load the 400 Hz level tape and play it back. Adjust the output level control to a certain level (example 0 dB). 2. Load the 10 kHz, 15 kHz and 20 kHz PB frequency response tapes and adjust the playback head azimuth to give maximum levels on the VTVM with each tape. Adjust L101 (L201) to obtain the following levels against 400 Hz level tape (normally peaking frequency will be adjusted at 23 kHz.) 10 kHz -20 dB \pm 2 dB 15 kHz -20 dB -2, + 3 dB 20 kHz -20 dB -1, + 4 dB 3. Conduct step 6 "Playback Head Azimuth Alignment" 4. If above is not sufficient refer to item 6.2.1. "Playback Frequency Response Adjustment".
10	Bias Oscillation Frequency		Coupling Bias Oscillator Signal (Main P.C.B. CN1-4) to Frequency Counter	Record, Pause	Main P.C.B. L302	Adjust the coil to obtain 105 kHz on the frequency counter.

Note: When record/playback head is replaced, twist the signal wires (red and white) which are soldered to head terminals for reducing the interference of hum.

STEP	ITEM	SIGNAL SOURCE	OUTPUT CONNECTION	MODE	ADJUSTMENT	REMARKS
11	Record Amplifier Equalizer	23 kHz (-20 dB) to INPUT Jacks	VTVM to Main P.C.B. Test Pin TP-L, TP-R	Record, Pause Tape SW - SX Eq. SW - 70 μ s Dolby NR SW - OUT MPX SW - OUT	Main P.C.B. L104, L204	1. Remove the bias-cut-jumper from the dip side of the main P.C.B. 2. Adjust the coils to obtain peak readings at 23 kHz. 3. Resolder bias-cut-jumper.
12	Bias Trap (Playback Amp.)	Remove Input Signals	Same as above	Same as above	Main P.C.B. L105, L205	Adjust the coils to obtain maximum reading on the VTVM.
13	Record Level Calibration	400 Hz Test Tone or 400 Hz to INPUT Jacks	VTVM to OUTPUT Jacks	Record and Playback Tape SW - EX/SX Eq. SW - 120 μ s (EX) 70 μ s (SX) Dolby NR SW - OUT MPX SW - OUT Tone SW - ON Tone Freq. SW - 400 Hz	Cal. B P.C.B. VR705, VR805 VR706, VR806	1. Record signals on the reference EXII tape (DA09021A) or reference SX tape (DA09025A) then play it back. 2. Repeating 1 as above, adjust VR706 (VR806) (for EXII) and VR705 (VR805) (for SX) to obtain 0 dB on the level meters in playback mode. Note: Record calibration controls on the front panel (VR703, 803, 704, 804 - Cal. A P.C.B.) should be locked at the center position.
14	Recording Bias Current and Record/Playback Level	400 Hz Test Tone or 400 Hz to INPUT Jacks and 40 Hz to 20 kHz (-20 dB) to INPUT Jacks	VTVM and Distortion Meter to OUTPUT Jacks	Same as above	Cal. B. P.C.B. VR701, VR801 VR702, VR802 (Front Panel Bias Calibration Semi-fixed Volume)	1. Feed in 400 Hz and adjust record level controls to obtain 0 dB on the level meters. 2. Record signals on the reference EXII tape (DA09021A) or SX tape (DA09025A). 3. Repeating 2 as above, play back the tape and adjust VR701 (VR801) (for EXII) or VR702 (VR802) (for SX) to obtain maximum reading on the VTVM. 4. Conduct step 13 "Record Level Calibration". 5. Feed in 10 kHz (-20 dB) then record and play it back. Adjust VR701 (VR801) (for EXII) or VR702 (VR802) (for SX) to obtain approximately -20 dB on the VTVM. 6. Feed in 20 kHz (-20 dB) then record and play it back. Adjust recording peaking coil L104 (L204) to obtain approximately -20 dB on the VTVM (refer to step 11 "Record Amplifier Equalizer"). 7. Feed in 400 Hz and adjust the record level controls to obtain 0 dB on the level meters, then record and play it back and check whether the Total Harmonic Distortion (T.H.D.) is less than 1.5%. 8. Feed in 40 Hz to 20 kHz (-20 dB) then record and play it back, and check to insure if the output levels are within -20 dB \pm 3 dB. 9. If T.H.D. exceeds 1.5%, the following adjustments are required: a. Repeat 5 as above. Adjust bias calibration semi-fixed volumes and peaking coils to obtain -22 dB instead of -20 dB on the VTVM. b. Perform step 13 "Record Level Calibration". c. Repeat 7 as above. d. If above is not sufficient, precise readjustment of step 9 "Playback Frequency Response", replacement of Record/Playback Head, or check of item 5.13 "Tape Travelling Adjustment" will be required. 10. Conduct step 13 "Record Level Calibration". Note: Bias adjustment controls on the front panel (VR302, 303 - Cal. A P.C.B.) should be locked at the center position.

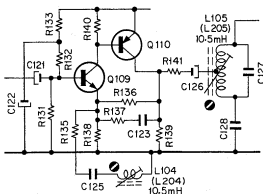

Fig. 6.1.8 Record Amp. Eq. and Bias Trap (PB Amp.)

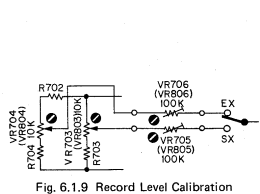

Fig. 6.1.9 Record Level Calibration

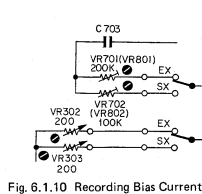

Fig. 6.1.10 Recording Bias Current and Record/Playback Level

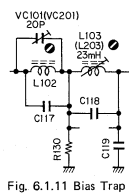

Fig. 6.1.11 Bias Trap (Line Amp.)

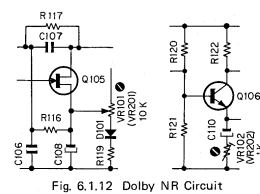

Fig. 6.1.12 Dolby NR Circuit

STEP	ITEM	SIGNAL SOURCE	OUTPUT CONNECTION	MODE	ADJUSTMENT	REMARKS
15	Bias Trap (Line Amp.)	Remove Input Signals	VTVM to OUTPUT Jacks	Record, Pause Tape SW - SX Eq. SW - 70 μ s Dolby NR SW - OUT MPX SW - OUT	Main P.C.B. VC101, VC201	1. Set output level control to maximum position. 2. Adjust VC101 (VC201) to obtain minimum reading on the VTVM.
16	Dolby NR Circuit	5 kHz to INPUT Jacks	VTVM to Dolby NR P.C.B. Connector Terminal	Record, Pause MPX SW - IN	Dolby NR P.C.B. VR101, VR201 VR102, VR202	Adjust only if board is repaired. 1. Remove the bias-cut-jumper from the dip side of the main P.C.B. 2. Turn LAW control VR101 (VR201) fully counterclockwise. 3. Turn GAIN control VR102 (VR202) fully counterclockwise. 4. Set Dolby NR switch to OUT position and short Test Pin TP101 (TP201) to ground. 5. Connect a VTVM to Metering Terminal 3 for the Right channel or 12 for the Left channel. 6. Apply 5 kHz signals having a proper level to INPUT so that the VTVM may read 17.5 mV at each channel. 7. Remove the VTVM from Terminal 3 or 12 and re-connect it to OUTPUT terminal 6 or 9. Note the output voltage on the VTVM. 8. Set Dolby NR switch to IN position and adjust GAIN control VR102 (VR202) till the VTVM indicates 10 dB over the noted voltage in 7 as above. 9. Set Dolby NR switch to IN position. Note the voltage at OUTPUT Terminal 6 for the Right channel or 9 for the Left channel. 10. Remove TP101 (TP201) short and adjust LAW control VR101 (VR201) for a 2 dB drop in the voltage at OUTPUT Terminal. 11. Resolder the bias-cut-jumper.
17	Crosstalk	1 kHz to INPUT Jacks	1 kHz Band Pass Filter, VTVM to OUTPUT Jacks	Record and Playback Tape SW - SX Eq. SW - 70 μ s Dolby NR SW - OUT MPX SW - IN		1. Erase the tape with bulk eraser. 2. Adjust record level controls to obtain 0 dB on the level meters, and record the signals on the reference tape. 3. Turn the cassette tape the other way round and play it back. 4. Measure the difference between 2 and 3.
18	Channel Separation	1 kHz to INPUT Jacks	Same as above	Same as above		1. Erase the tape with bulk eraser. 2. Adjust Lch (Rch) record level control to obtain 0 dB on the level meter, and close Rch (Lch) record level control. 3. Record and play it back, then measure the Rch (Lch) level.
19	Erasure	1 kHz to INPUT Jacks	Same as above	Same as above		1. Erase the tape with bulk eraser. 2. Adjust record level controls to obtain 0 dB on the level meters, and record the signals on the reference tape. 3. Rewind the Tape then close record level controls. 4. Record and play it back, then measure the difference between 2 and 3.
20	Signal to Noise Ratio	400 Hz to INPUT Jacks	VTVM and Distortion Meter to OUTPUT Jacks	Record and Playback Tape SW - SX Eq. SW - 70 μ s Dolby NR SW - IN MPX SW - IN		1. Feed in 400 Hz and record, and play it back. 2. Adjust the record level controls to obtain 3% total harmonic distortion in playback mode. 3. Close the record level controls then record. 4. After rewound, play back and check the output level difference between 2 and 3. Note: The filter of CCITT curve shall be used in the measurements.
21	Total Harmonic Distortion	400 Hz to INPUT Jacks	Distortion Meter to OUTPUT Jacks	Record and Playback Tape SW - EX/SX Eq. SW - 120 μ s (EX) 70 μ s (SX) Dolby NR SW - OUT MPX SW - IN		1. Adjust record level controls to obtain 0 dB on the level meters. 2. Record and play it back. 3. Read the distortion meter.
22	Wow/Flutter	3 kHz Speed and Wow/Flutter Tape (DA09006A)	Wow/Flutter Meter to OUTPUT Jacks	Playback		Playback and read the wow/flutter meter.

6.2. Frequency Response Adjustment

6.2.1. Playback Frequency Response Adjustment

Fig. 6.2.1 shows the playback equalization curve for Nakamichi 600II, and Fig. 6.2.2 is the circuit for adjustment.

(1) Level Adjustment (for middle frequency response): This adjustment will be required when playback level is not sufficient at 10 kHz PB Frequency Response Tape (refer to item 6.1.9.).

Playback equalization level can be varied by the modification of R102 (R202) and R103 (R203).

Following are the details for level modification:

- About +2 dB R102 (R202): 1.5 k
R103 (R203): 22 k
- About +1 dB R102 (R202): 1.5 k
R103 (R203): 10 k
- 0 dB R102 (R202): 1.2 k
R103 (R203): 22 k
- About -1 dB R102 (R202): 1.2 k
R103 (R203): 6.8 k

(2) Peaking Adjustment (for high frequency response): This adjustment will be required when playback level is not sufficient at 20 kHz PB Frequency Response Tape (refer to item 6.1.9.).

Peaking portion compensates the air gap loss of the playback head. Peaking frequency is varied by the coil L101 (L201) and peaking level is varied by the short circuit of R109 (R209) or R110 (R210) as illustrated in the figure.

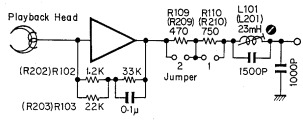

Fig. 6.2.2 Playback Amp.

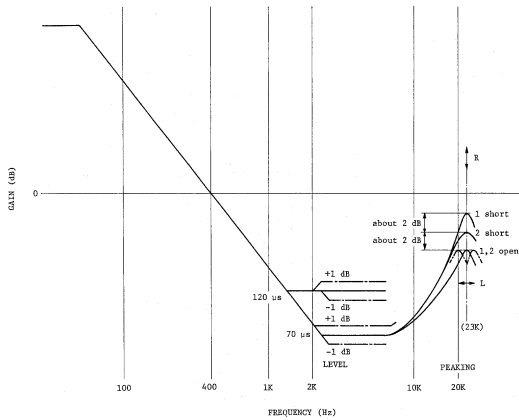

Fig. 6.2.1 Playback Equalization Curve

6.2.2. Record Current Frequency Response Adjustment
Record Eq. peaking is adjusted for compensating the overall frequency response when playback frequency response is completed.

Normally however peaking frequency is pre-adjusted to 23 kHz in record mode. See Fig. 6.2.3.

After completion of playback frequency response adjustment, check the overall frequency response at 10 kHz for SX tape and at 20 kHz for EX tape, then compensates if required.

(1) For SX Tape

a. Feed in 400 Hz (0 dB), then record and play it back. Adjust bias current by VR702 (VR802) to obtain a 1.2% distortion.

b. Feed in 10 kHz and 400 Hz (-20 dB) then record and play it back. Check the difference of the levels between 10 kHz and 400 Hz, and mount an additional capacitor in parallel with the C129 (C229) from the dip side of the printed circuit board depending upon the difference of the levels against 400 Hz. See Fig. 6.2.4.

	Add	Total
0 dB	0	1200 pF
-1 dB	470 pF	1670 pF
-2 dB	1000 pF	2200 pF
-3 dB	2200 pF	3400 pF

c. Feed in 20 kHz (-20 dB) then record and play it back. Adjust record peaking coils L104 (L204) to obtain flat overall frequency response.

(2) For EX Tape

a. Feed in 10 kHz and 400 Hz (-20 dB), then record and play it back. Adjust bias current by VR701 (VR801) to obtain flat overall frequency response.

b. Feed in 20 kHz and 400 Hz (-20 dB), then record and play it back.
If the level at 20 kHz is higher than the level at 400 Hz over 3 dB, mount an additional capacitor (C: 1000 pF) as shown in Fig. 6.2.5 to compensate the overall frequency response.

(This compensation will normally be required when compensation for SX tape is performed.)

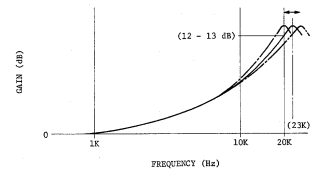

Fig. 6.2.3

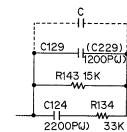

Fig. 6.2.4 Main P.C.B.

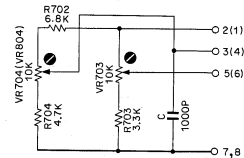

Fig. 6.2.5 Cal. A P.C.B.

7. PARTS LOCATION FOR ELECTRICAL ADJUSTMENT

Note: For adjustment, removal of meter ass'y is required (see item 3.20 meter ass'y removal procedure).
When a check is made on Amp., etc. by means of an extension cord, re-adjustment shall be made without fail (after final installation to the model chassis.)

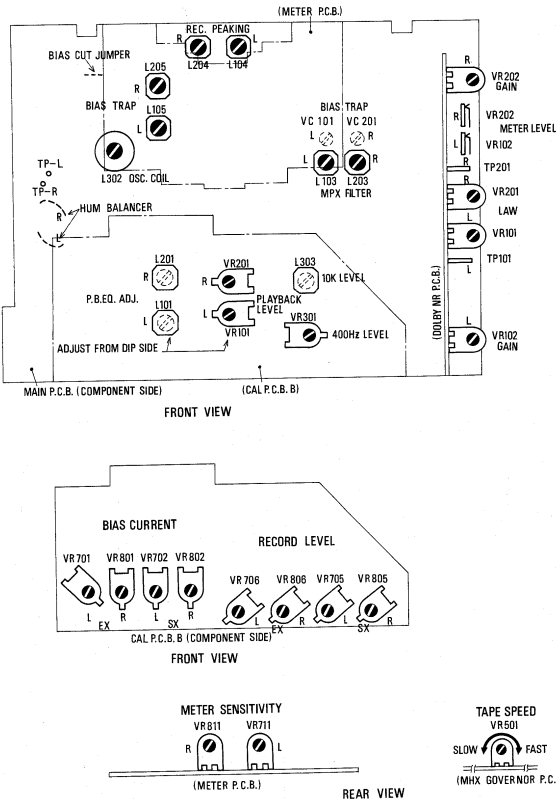

Fig. 7

8. MOUNTING DIAGRAM AND PARTS LIST

Note: Mounting diagram shows a dip side view of the printed circuit board.

8.1. Dolby NR P.C.B. Ass'y

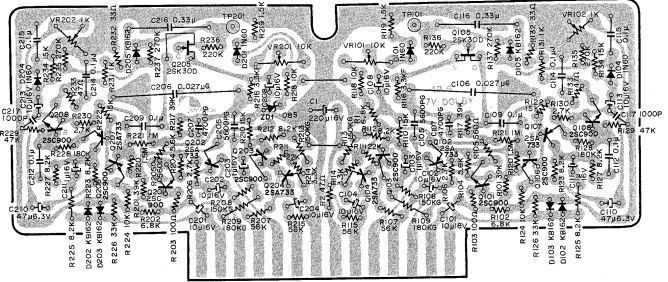

Fig. 8.1

Schematic Ref. No.	Part No.	Description	Schematic Ref. No.	Part No.	Description
	BA03670A	Dolby NR P.C.B. Ass'y	125, 127		
			212, 223		
			225, 227		
Q101, 103	0B07609B	17V Dolby NR P.C.B.	R114, 214	0B01793A	Carbon Resistor 3.3K ERD-25V J
106, 108	0B01910A	Transistor 2SC900	R116, 216	0B01585A	Metal Film Resistor 3.3K ERO-25VK F
201, 203			R118, 124	0B01833A	Carbon Resistor 10K ERD-25V J
206, 208			218, 224		
Q102, 104	0B06013A	Transistor 2SA733	R119, 219	0B05505A	Carbon Resistor 1.5K ERD-25V J
107, 202			R120, 220	0B05601A	Carbon Resistor 1.5M ERD-25V J
204, 207			R121, 221	0B05564A	Carbon Resistor 1M ERD-25V J
Q105, 205	0B06001A	FET 2SK30A (D)	R126, 226	0B01879A	Carbon Resistor 33K ERD-25V J
ZD1	0B06004A	Zener Diode EQA08S	R128, 228	0B05669A	Carbon Resistor 180K ERD-25V J
D101, 104	0B00030A	Germanium Diode 1N60 (P)	R129, 229	0B05562A	Carbon Resistor 47K ERD-25V J
201, 204			R131, 231	0B01781A	Carbon Resistor 1K ERD-25V J
D102, 103	0B01599A	Silicon Varistor KB162	R132, 232	0B05567A	Carbon Resistor 33 ERD-25V J
105, 202			R135, 137	0B05600A	Carbon Resistor 270K ERD-25V J
203, 205			235, 237		
VR101, 201	0B01458A	Semi-fixed Volume 10K	R136, 236	0B05596A	Carbon Resistor 220K ERD-25V J
VR102, 202	0B01428A	Semi-fixed Volume 1K	C1	0B01398A	Electrolytic Capacitor 220u 16V
R1, 102, 202	0B01877A	Carbon Resistor 6.8K ERD-25V J	C101, 102	0B01412A	Electrolytic Capacitor 10u 16V
R2, 133, 233	0B05569A	Carbon Resistor 47 ERD-25V J	104, 108		
R101, 117	0B01885A	Carbon Resistor 39K ERD-25V J	113, 201		
201, 217			202, 204		
R103, 203	0B05558A	Carbon Resistor 100 ERD-25V J	208, 213		
R104, 204	0B05673A	Carbon Resistor 5.6K ERD-25V J	C103, 111	0B01405A	Electrolytic Capacitor 1u 16V
R105, 205	0B05678A	Carbon Resistor 560 ERD-25V J	203, 211		
R106, 130	0B01782A	Carbon Resistor 2.7K ERD-25V J	C105, 205	0B01864A	P.P. Capacitor 5600P 50V G
206, 230			C106, 206	0B01892A	P.P. Capacitor 0.027u 50V G
R107, 115	0B05563A	Carbon Resistor 56K ERD-25V J	C107, 207	0B01608A	P.P. Capacitor 4700P 50V G
207, 215			C109, 112	0B01603A	Mylar Capacitor 0.1u 50V K
R108, 113	0B01859A	Metal Film Resistor 150K ERO-25VK G	115, 209		
208, 213			212, 215		
R109, 209	0B01590A	Metal Film Resistor 180K ERO-25VK G	C110, 210	0B01404A	Electrolytic Capacitor 47u 6.3V
R110, 122	0B05591A	Carbon Resistor 15K ERD-25V J	C114, 214	0B01780A	Mylar Capacitor 0.1u 50V J
134, 210			C116, 216	0B01602A	Mylar Capacitor 0.33u 50V K
222, 234			C117, 217	0B04059A	Mylar Capacitor 1000P 50V K
R111, 211	0B05561A	Carbon Resistor 22K ERD-25V J	TP101, 201	0B03924A	Gate Pin
R112, 123	0B01878A	Carbon Resistor 8.2K ERD-25V J			

8.2. Main P.C.B. Ass'y

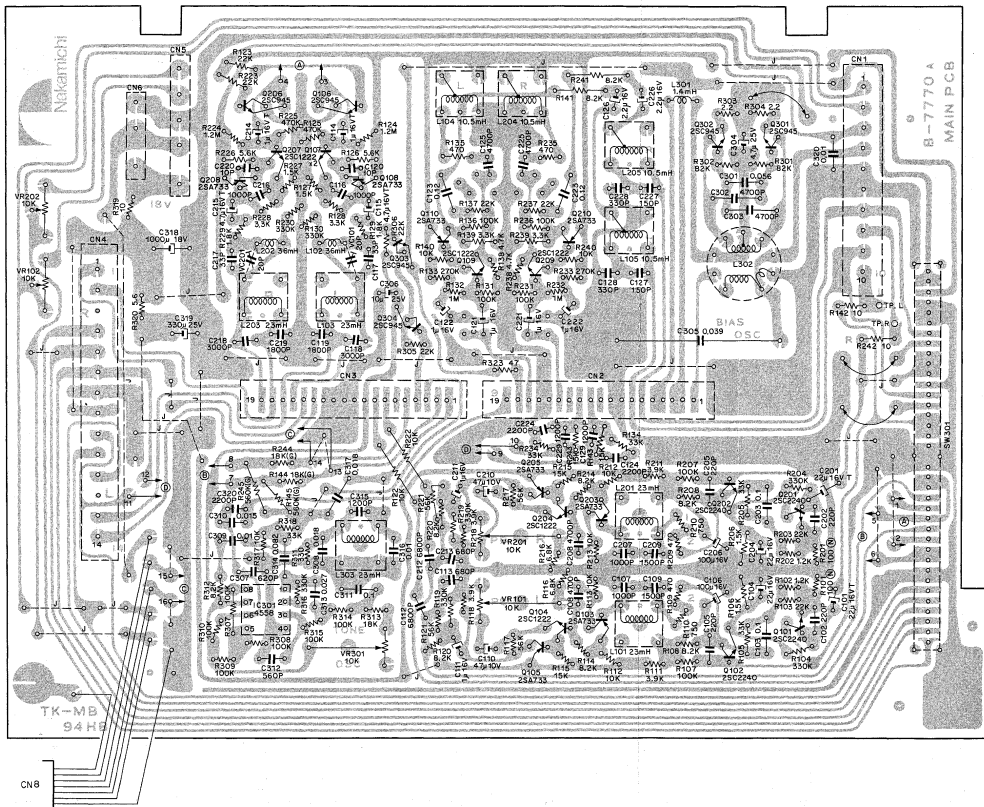

Fig. 8.2

Schematic Ref. No.	Part No.	Description
	BA03898A	Main P.C.B. Ass'y
		- PB Eq. Amp. -
Q101, 102	0B06142A	Transistor 2SC2240 (BL)
201, 202	0B06142A	Transistor 2SC2240 (BL)
Q103, 105	0B06013A	Transistor 2SA733
203, 205	0B06013A	Transistor 2SA733
Q104, 204	0B06062A	Transistor 2SC1222(2)
L101, 201	0B03857A	19K Coil 23mH
VR101, 201	0B01595A	Semi-fixed Volume 10K
R101, 201	0B05833A	Carbon Resistor 100 ERD-25V J (Noiseless)
R102, 202	0B05665A	Carbon Resistor 1.2K ERD-25V J
R103, 203	0B05661A	Carbon Resistor 22K ERD-25V J
R104, 119	0B01921A	Carbon Resistor 330K ERD-25V J
204, 219	0B01921A	Carbon Resistor 330K ERD-25V J
R105, 205	0B01879A	Carbon Resistor 33K ERD-25V J
R106, 206	0B05505A	Carbon Resistor 1.5K ERD-25V J
R107, 207	0B01920A	Carbon Resistor 100K ERD-25V J
R108, 114	0B01878A	Carbon Resistor 8.2K ERD-25V J
120, 208	0B01878A	Carbon Resistor 8.2K ERD-25V J
214, 220	0B01792A	Carbon Resistor 470 ERD-25V J
R109, 209	0B05835A	Carbon Resistor 750 ERD-25V J
R110, 210	0B05835A	Carbon Resistor 750 ERD-25V J
R111, 118	0B05864A	Carbon Resistor 3.9K ERD-25V J
211, 218	0B05864A	Carbon Resistor 3.9K ERD-25V J
R112, 113	0B01833A	Carbon Resistor 10K ERD-25V J
212, 213	0B01833A	Carbon Resistor 10K ERD-25V J
R115, 215	0B05591A	Carbon Resistor 15K ERD-25V J
R116, 216	0B01877A	Carbon Resistor 6.8K ERD-25V J
R117, 121	0B05563A	Carbon Resistor 56K ERD-25V J
217, 221	0B05563A	Carbon Resistor 56K ERD-25V J
R122, 222	0B01888A	Carbon Resistor 10K ERD-25T J
C101, 201	0B05636A	Tantalum Capacitor 22μ 16V
C102, 105	0B01289A	Ceramic Capacitor 220P 50V
202, 205	0B01289A	Ceramic Capacitor 220P 50V
C103, 203	0B01780A	Mylar Capacitor 0.1μ 50V J
C104, 204	0B01862A	Electrolytic Capacitor 22μ 16V
C106, 206	0B01400A	Electrolytic Capacitor 100μ 16V
C107, 207	0B05550A	Mylar Capacitor 1000P 50V J
C108, 208	0B05652A	Mylar Capacitor 4700P 50V J
C109, 209	0B05653A	Mylar Capacitor 1500P 50V J
C110, 210	0B01836A	Electrolytic Capacitor 47μ 10V
C111, 211	0B01405A	Electrolytic Capacitor 1μ 16V
C112, 212	0B05530A	Mylar Capacitor 6800P 50V J
C113, 213	0B09078A	S.P. Capacitor 680P 50V J
JA03033A	JA03033A	Noise Shield A Ass'y (2 pcs.) (Assembled with L101, 201)
		- Line Amp. -
Q106, 206	0B01872A	Transistor 2SC945 (L)
Q107, 207	0B06062A	Transistor 2SC1222(2)
Q108, 208	0B06013A	Transistor 2SA733
L102, 202	0B03919A	Inductor 36mH
L103, 203	0B03563A	19K Coil 23mH
R123, 223	0B05661A	Carbon Resistor 22K ERD-25V J
R124, 224	0B05537A	Carbon Resistor 1.2M ERD-25V J
R125, 225	0B05700A	Carbon Resistor 470K ERD-25V J
R126, 226	0B05673A	Carbon Resistor 5.6K ERD-25V J
R127, 227	0B05505A	Carbon Resistor 1.5K ERD-25V J
R128, 228	0B01795A	Carbon Resistor 3.3K ERD-25V J

8. 3. Cal. A P.C.B. Ass'y

C (1000 pF): Mounted if compensation is required.

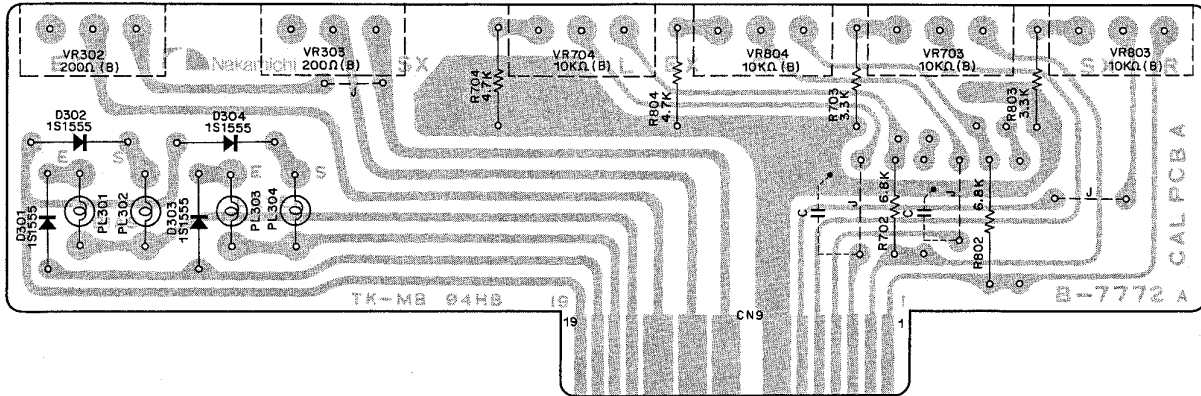

Fig. 8.3

8. 4. Cal. B P.C.B. Ass'y

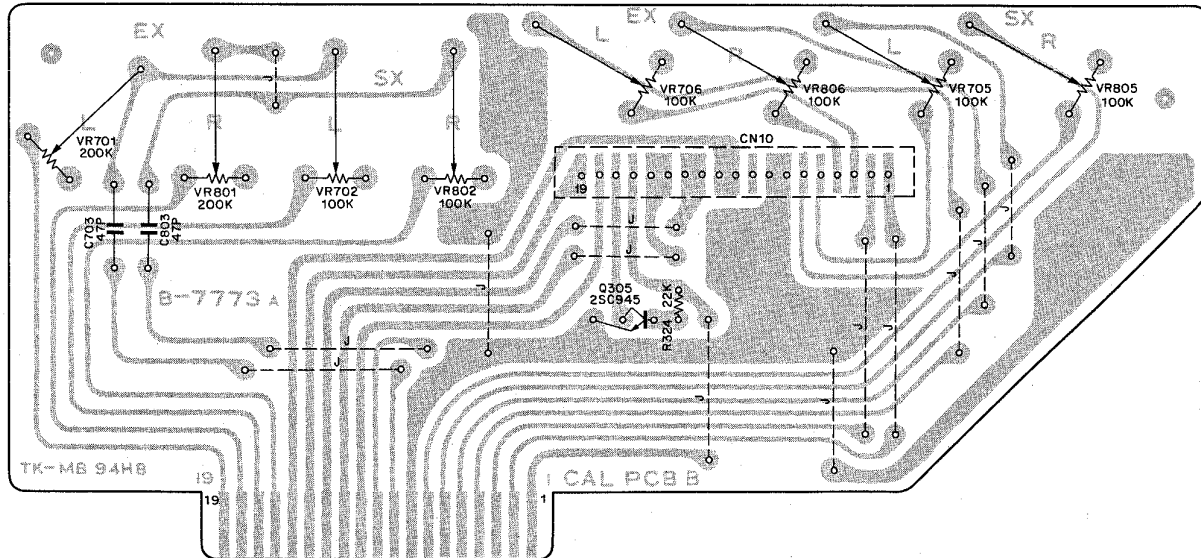

Fig. 8.4

Schematic Ref. No.	Part No.	Description	Schematic Ref. No.	Part No.	Description
	BA03900A	Cal. P.C.B. A Ass'y		BA03901A	Cal. P.C.B. B Ass'y
D301, 302, 303, 304	OB07772A OB01909A	Cal. P.C.B. A Silicon Diode		OB07773A	Cal. P.C.B. B
VR302, 303	OB07201A	Volume	Q305	OB01872A	Transistor
VR703, 704, 803, 804	OB07200A	Volume	VR701, 801	OB01597A	Semi-fixed Volume
R702, 802	OB01682A	Carbon Resistor	VR702, 705, 706, 802, 805, 806	OB01812A	Semi-fixed Volume
R703, 803	OB01681A	Carbon Resistor	R324	OB05661A	Carbon Resistor
R704, 804	OB01846A	Carbon Resistor	C703, 803	OB01456A	Ceramic Capacitor
PL301, 302, 303, 304	OJ03570A	Lamp	CN10	BA03808A	19P Connector Ass'y
	OH03636A	Lamp Cap A206 (4 pcs.)			

8.5. Switch P.C.B. Ass'y

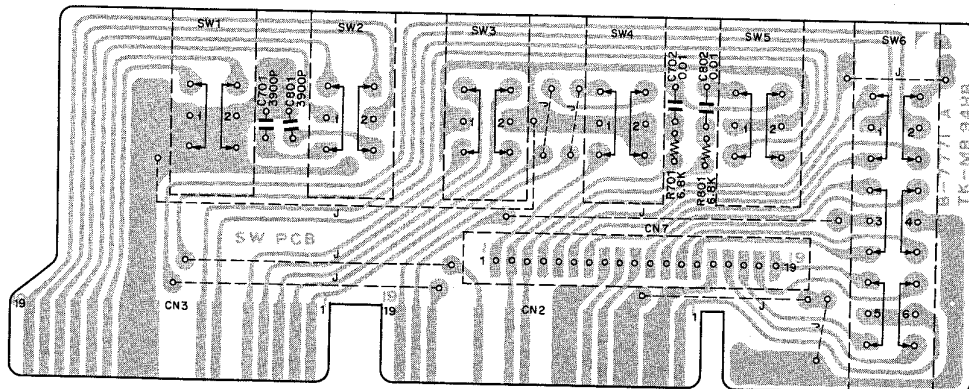

Fig. 8.5

8.6. VR P.C.B. Ass'y

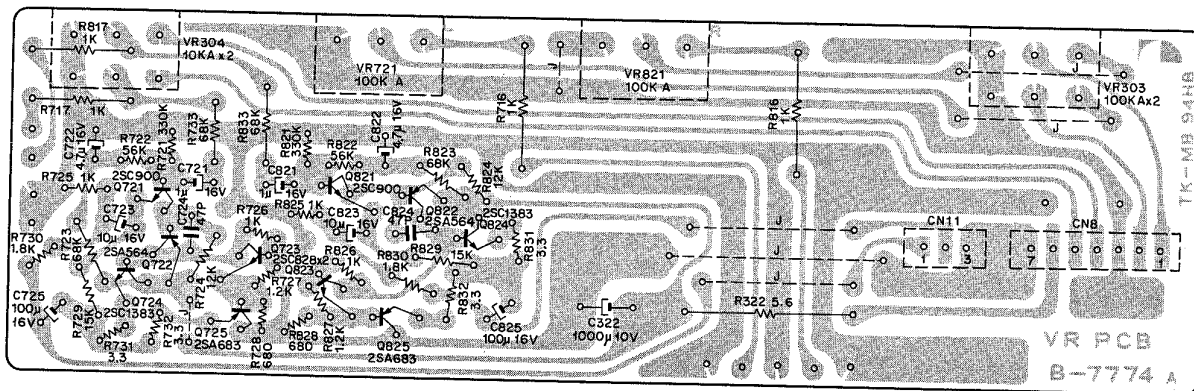

Fig. 8.6

Schematic Ref. No.	Part No.	Description	Schematic Ref. No.	Part No.	Description	
R701, 801 C701, 801 C702, 802 CN7	BA03899A	Switch P.C.B. Ass'y	R727, 827	0B05565A	Carbon Resistor 1.2K ERD-25V J	
	OB07771A	Switch P.C.B.	R728, 828	0B05559A	Carbon Resistor 680 ERD-25V J	
	OB01877A	Carbon Resistor 6.8K ERD-25V J	R729, 829	0B05591A	Carbon Resistor 15K ERD-25V J	
	OB01804A	Mylar Capacitor 3900P 50V J	R730, 830	0B01830A	Carbon Resistor 1.8K ERD-25V J	
	OB05681A	Mylar Capacitor 0.01μ 50V J	R731, 732 831, 832	0B05779A	Carbon Resistor 3.3 ERD-25V J	
	BA03808A	19P Connector Ass'y	C322	0B05852A	Electrolytic Capacitor 1000μ 10V	
	OB07088A	Push Switch (1 pce.)	C721, 821	0B01405A	Electrolytic Capacitor 1μ 16V	
Q721, 821 Q722, 822 Q723, 823 Q724, 824 Q725, 825 R322 R721, 821 R722, 822 R723, 733 823, 833 R724, 824 R725, 726 825, 826	BA03904A	VR P.C.B. Ass'y	C722, 822	0B01389A	Electrolytic Capacitor 4.7μ 16V	
	- Headphone Amp. -		C723, 823	0B01412A	Electrolytic Capacitor 10μ 16V	
	Q721, 821	OB01910A	Transistor 2SC900	C724, 824	0B01456A	Ceramic Capacitor 47P 50V
	Q722, 822	OB06053A	Transistor 2SA564	C725, 825	0B01400A	Electrolytic Capacitor 100μ 16V
	Q723, 823	OB01824A	Transistor 2SC828	- Miscellaneous -		
	Q724, 824	OB06052A	Transistor 2SC1383	OB07774A	VR P.C.B.	
	Q725, 825	OB06051A	Transistor 2SA683	OB07203A	Volume 100K(A) x 2	
	R322	OB05940A	Fail Safe Type Resistor 5.6 ERF-14F J	OB07204A	Volume 10K(A) x 2	
	R721, 821	OB01921A	Carbon Resistor 330K ERD-25V J	OB07202A	Volume 100K(A)	
	R722, 822	OB05563A	Carbon Resistor 56K ERD-25V J	OB01857A	Carbon Resistor 1K ERD-25T J	
	R723, 733 823, 833	OB01902A	Carbon Resistor 68K ERD-25V J			
	R724, 824	OB05650A	Carbon Resistor 12K ERD-25V J	CN8	0B08451A	7P-S Post
	R725, 726 825, 826	OB01781A	Carbon Resistor 1K ERD-25V J	CN11	0B08184A	3P-S Post

8. 9. Power Supply P.C.B. Ass'y

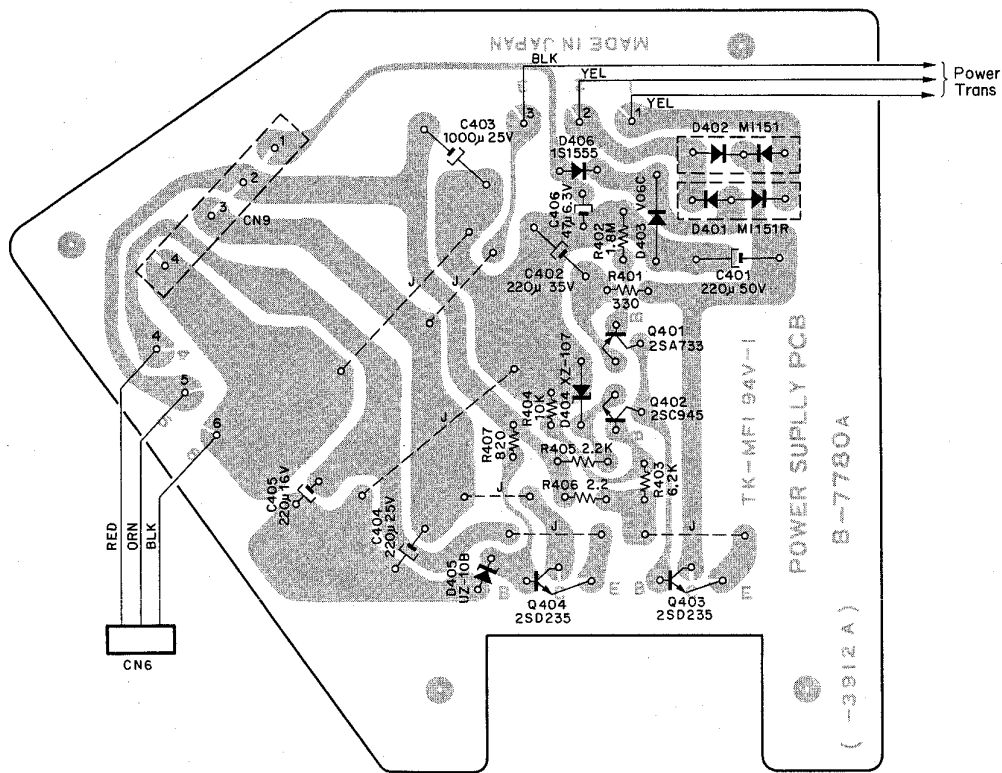

Fig. 8.9

Schematic Ref. No.	Part No.	Description	Schematic Ref. No.	Part No.	Description
	BA03903A	Power Supply P.C.B. Ass'y		0B08153A	3P Jack Ass'y 1 (1 pce.)
	0B07780A	Power Supply P.C.B.		0J03399A	Heat Sink (1 pce.)
Q401	0B06013A	Transistor 2SA733		0E00507A	Nut Hex. M3 (4 pcs.)
Q402	0B01872A	Transistor 2SC945		0E00607A	Screw M3x8 Philips Pan Head (3A) (2 pcs.)
Q403, 404	0B01823A	Transistor 2SD235(Y)		0E00608A	Screw M3x10 Philips Pan Head (3A) (2 pcs.)
D401	0B06093U	Silicon Diode MI-151R			
D402	0B06092U	Silicon Diode MI-151			
D403	0B01501U	Silicon Diode V06C			
D404	0B06059A	Zener Diode XZ107			
D405	0B06116A	Zener Diode UZ10B			
D406	0B01909A	Silicon Diode 1S1555			
R401	0B01789A	Carbon Resistor 330 ERD-25V J			
R402	0B05670A	Carbon Resistor 1.8M ERD-25V J			
R403	0B05823A	Carbon Resistor 6.2K ERD-25V J			
R404	0B01833A	Carbon Resistor 10K ERD-25V J			
R405	0B05566A	Carbon Resistor 2.2K ERD-25V J			
R406	0B05605A	Carbon Resistor 2.2 ERD-25V J			
R407	0B05511A	Carbon Resistor 820 ERD-25V J			
C401	0B05839A	Electrolytic Capacitor 220μ 50V			
C402	0B05831A	Electrolytic Capacitor 220μ 35V			
C403	0B01870A	Electrolytic Capacitor 1000μ 25V			
C404	0B01391A	Electrolytic Capacitor 220μ 25V			
C405	0B01398A	Electrolytic Capacitor 220μ 16V			
C406	0B01404A	Electrolytic Capacitor 47μ 6.3V			
	0B08127A	4P Plug Pin (1 pce.)			

Schematic Ref. No.	Part No.	Description	Schematic Ref. No.	Part No.	Description
	BA03950A	Shut-off P.C.B. Ass'y (Serial No. A206.7 05001 and greater)	R605, 609 620	0B01795A	Carbon Resistor 4.7K ERD-25V J
	0B07784A	Shut-off P.C.B.	R606, 607	0B05562A	Carbon Resistor 47K ERD-25V J
Q601	0B01695A	Transistor 2SA496	R608, 612 621, 625	0B01833A	Carbon Resistor 10K ERD-25V J
Q602, 603 604, 608	0B01872A	Transistor 2SC945	R610, 619	0B05505A	Carbon Resistor 1.5K ERD-25V J
Q605, 606 607	0B06013A	Transistor 2SA733	R611	0B05595A	Carbon Resistor 390K ERD-25V J
ZD601	0B06063A	Zener Diode YZ-040B	R613, 616 618, 630	0B05661A	Carbon Resistor 22K ERD-25V J
D601	0B06092U	Silicon Diode MI-151	R614	0B01877A	Carbon Resistor 6.8K ERD-25V J
D602, 603 604, 605	0B01909A	Silicon Diode 1S1555	R615	0B01792A	Carbon Resistor 470 ERD-25V J
R601, 604	0B01781A	Carbon Resistor 1K ERD-25V J	R617	0B05568A	Carbon Resistor 120K ERD-25V J
R602	0B01830A	Carbon Resistor 1.8K ERD-25V J	R622, 624	0B05597A	Carbon Resistor 680K ERD-25V J
R603	0B05569A	Carbon Resistor 47 ERD-25V J	R623	0B01921A	Carbon Resistor 330K ERD-25V J
R605, 609 620	0B01795A	Carbon Resistor 4.7K ERD-25V J	R627	0B05940A	Fail Safe Type Resistor 5.6 ERF-14F J
R606, 607	0B05562A	Carbon Resistor 47K ERD-25V J	R628	0B05674A	Carbon Resistor 820K ERD-25V J
R608, 612 621, 625	0B01833A	Carbon Resistor 10K ERD-25V J	R629	0B01920A	Carbon Resistor 100K ERD-25V J
R610, 619	0B05505A	Carbon Resistor 1.5K ERD-25V J	C601, 603 605	0B01173A	Electrolytic Capacitor 1 μ 25V
R611, 623	0B01921A	Carbon Resistor 330K ERD-25V J	C602, 611	0T04027A	Ceramic Capacitor 680P 50V
R613, 618 629	0B01920A	Carbon Resistor 100K ERD-25V J	C604, 608	0B05817A	Electrolytic Capacitor 33 μ 16V M(MS)
R614, 616 626, 630	0B05661A	Carbon Resistor 22K ERD-25V J	C606	0B01835A	Electrolytic Capacitor 2200 μ 18V
R615	0B01792A	Carbon Resistor 470 ERD-25V J	C607	0B01674A	Electrolytic Capacitor 10 μ 25V
R617	0B05568A	Carbon Resistor 120K ERD-25V J	C609	0B05815A	Electrolytic Capacitor 1.5 μ 25V M(MS)
R622, 624	0B05597A	Carbon Resistor 680K ERD-25V J	C610	0B01502A	Electrolytic Capacitor 330 μ 16V
R627	0B05940A	Fail Safe Type Resistor 5.6 ERF-14F J	C612	0B01609A	Mylar Capacitor 0.01 μ 50V
R628	0B05674A	Carbon Resistor 820K ERD-25V J		0B08001A	Tab (2 pcs.)
R629	0B01920A	Carbon Resistor 100K ERD-25V J		0B08152A	4P Jack Ass'y 2 (1 pce.)
C601, 603 605	0B01173A	Electrolytic Capacitor 1 μ 25V			
C602, 611	0T04027A	Ceramic Capacitor 680P 50V			
C604	0B09116A	Electrolytic Capacitor 15 μ 16V M(MS)			
C605	0B01664A	Electrolytic Capacitor 0.22 μ 25V M(MS)			
C606	0B01835A	Electrolytic Capacitor 2200 μ 18V			
C607	0B01674A	Electrolytic Capacitor 10 μ 25V			
C608	0B05817A	Electrolytic Capacitor 33 μ 16V M(MS)			
C609	0B05815A	Electrolytic Capacitor 1.5 μ 25V M(MS)			
C610	0B01502A	Electrolytic Capacitor 330 μ 16V			
C612	0B01609A	Mylar Capacitor 0.01 μ 50V			
C613	0B09117A	Electrolytic Capacitor 10 μ 25V M(MS)			
	BA03722B	Shut-off P.C.B. Ass'y (Up to serial No. A206.7 05000)			
	0B07639D	Shut-off P.C.B.			
Q601	0B01695A	Transistor 2SA496			
Q602, 603 604, 608	0B01872A	Transistor 2SC945			
Q605, 606 607	0B06013A	Transistor 2SA733			
ZD601	0B06063A	Zener Diode YZ-040B			
D601	0B06092U	Silicon Diode MI-151			
D602, 603 604, 605	0B01909A	Silicon Diode 1S1555			
R601, 604	0B01781A	Carbon Resistor 1K ERD-25V J			
R602	0B01830A	Carbon Resistor 1.8K ERD-25V J			
R603	0B05569A	Carbon Resistor 47 ERD-25V J			
				0B08204A	MHX Governor B

9. MECHANISM ASS'Y AND PARTS LIST

9.1. Synthesis (A01)

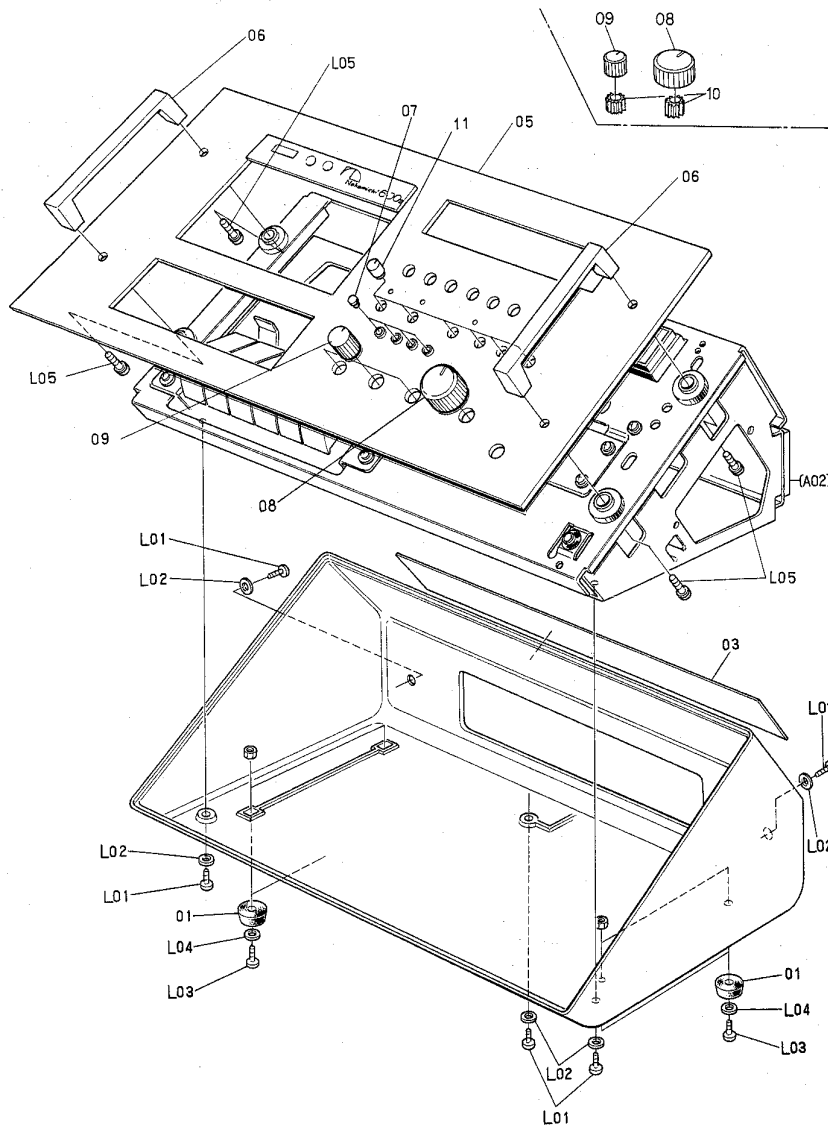

Fig. 9.1

Schematic Ref. No.	Part No.	Description	Q'ty	Schematic Ref. No.	Part No.	Description	Q'ty
A01		Synthesis		07	0H03399A	S.F.R. Cover	4
01	0A00518C	Rubber Foot	4	08	0H03412A	VR Cap B	1
02	0A03253A	Cabinet	1	09	0H03411A	VR Cap A	3
	0M03619A	Gate Screen Plate	1	10	0H03580A	VR Sleeve B	4
	0M03339A	Caution Label	1	11	HA03746A	VR Knob D Ass'y	6
03	0M03885A	Cabinet Plate	1	L01	0E00594A	Screw M3x8 Philips Binding Head (Bronze)	5
04	JA03232A	Chassis Ass'y	1	L02	0E00197A	Washer 3mm Bronze	5
05	HA03756A	Front Panel Ass'y Black	1	L03	0E00701A	Screw M3x10 Philips Binding Head (Bronze)	4
	HA03742A	Front Panel Ass'y Silver	1	L04	0E00253A	Washer 3mm	4
06	HA03675A	Handle Ass'y Black	2	L05	0E00700A	Screw M5x16 Philips Pan Head (2A)	4
	HA03632A	Handle Ass'y Silver	2				

9. 2. Chassis Ass'y

9. 2.1. Chassis Ass'y (1/2) (A02-1)

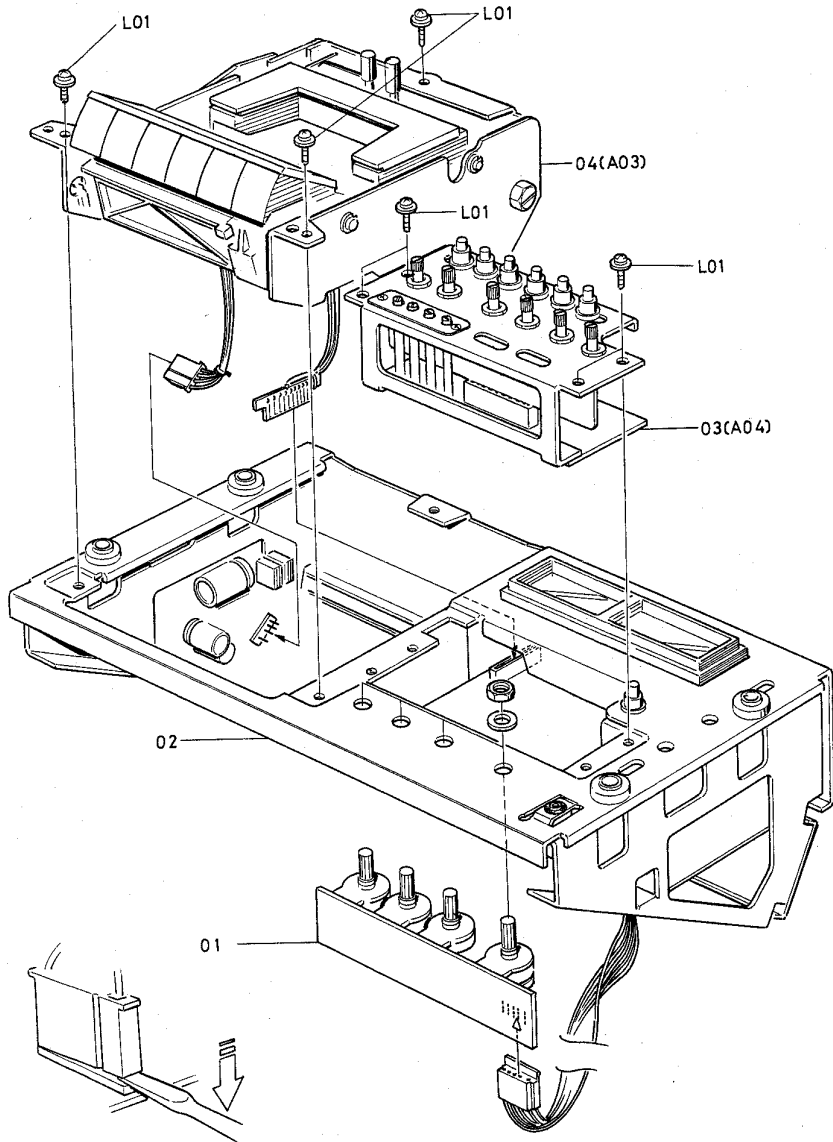

Fig. 9.2.1

Schematic Ref. No.	Part No.	Description	Q'ty	Schematic Ref. No.	Part No.	Description	Q'ty
A02-1	JA03316A	Chassis Ass'y (1/2) Black	1	A02-1	JA03232A	Chassis Ass'y (1/2) Silver	1
01	BA03904A	VR P.C.B. Ass'y	1	01	BA03904A	VR P.C.B. Ass'y	1
02	JA03231A	Main Chassis Ass'y	1	02	JA03231A	Main Chassis Ass'y	1
03	JA03229A	Front Control Ass'y	1	03	JA03229A	Front Control Ass'y	1
04	CA03310A	600II Mechanism Ass'y Black	1	04	CA03255B	600II Mechanism Ass'y Silver	1
L01	0E00606A	Screw M3x6 Philips Pan Head (3A)	7	L01	0E00606A	Screw M3x6 Philips Pan Head (3A)	7

9. 2.2. Chassis Ass'y (2/2) (A02-2)

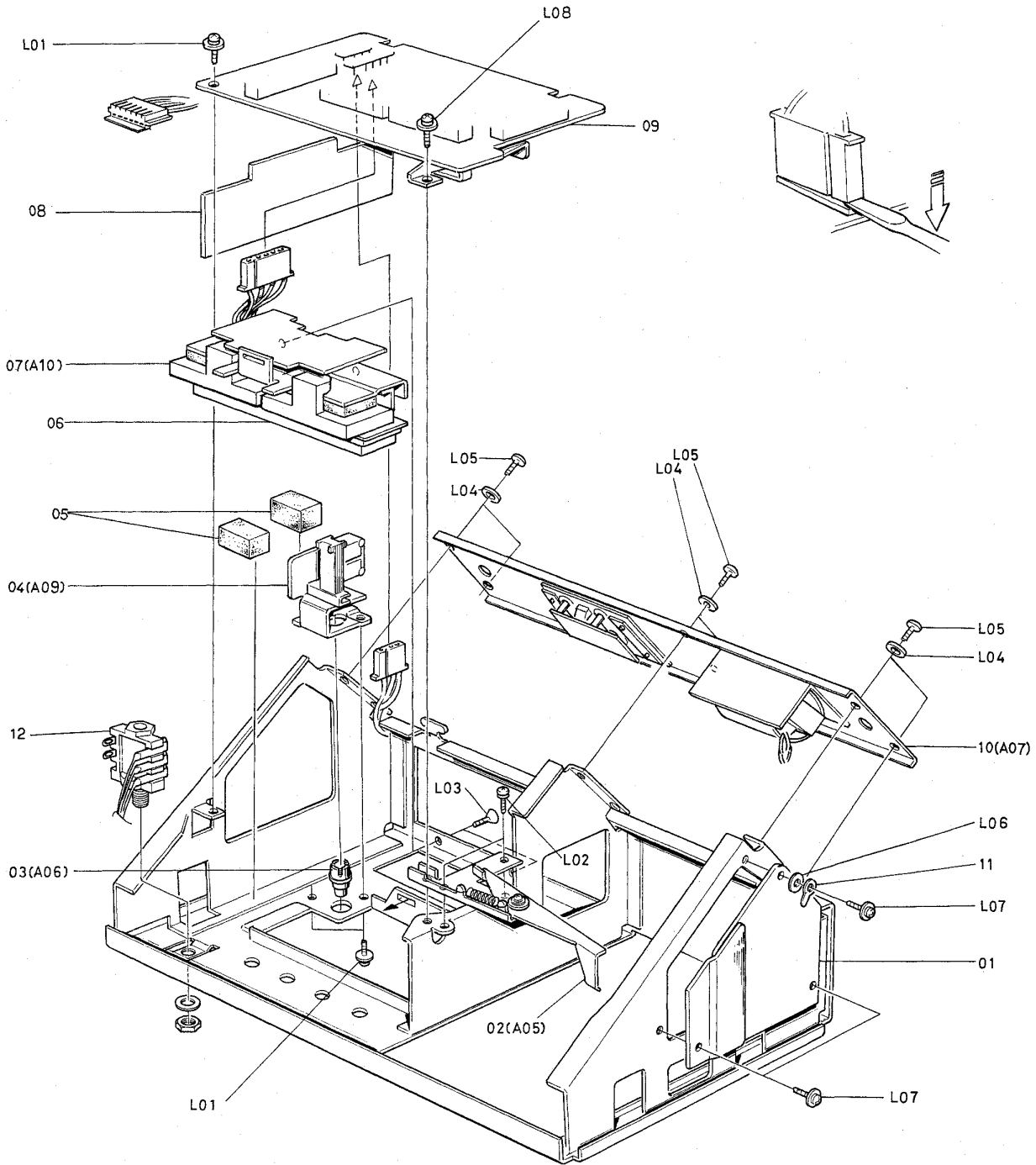

Fig. 9.2.2

Schematic Ref. No.	Part No.	Description	Q'ty
A02-2	JA03316A	Chassis Ass'y (2/2) Black	1
01	BA03903A	Power Supply P.C.B. Ass'y	1
02	JA03064A	Record Link Ass'y	1
03	JA03061A	Push Button Ass'y	1
04	JA03063A	Power Switch Ass'y	1
05	OJ03421A	Dolby NR P.C.B. Pad	2
06	OJ03417A	Meter Escutcheon	1
07	JA03230A	Meter Ass'y	1
08	BA03670A	Dolby NR P.C.B. Ass'y	1
09	BA03902A	Main P.C.B. Ass'y	1
10	JA03226A	Rear Panel Ass'y 120V	1
	JA03236A	Rear Panel Ass'y 220V	1
	JA03234A	Rear Panel Ass'y 220V/240V	1
	JA03237A	Rear Panel Ass'y 240V	1
	JA03239A	Rear Panel Ass'y 220V	1
	JA03238A	Rear Panel Ass'y 240V	1
	JA03233A	Rear Panel Ass'y 100V	1
11	0E00037A	Earth Lug B-5	2
12	0B08452A	Headphone Jack	1
L01	0E00606A	Screw M3x6 Philips Pan Head (3A)	3
L02	0E00612A	Screw M3x6 Philips Pan Head (2A)	2
L03	0E00505A	Screw M3x6 Philips Countersunk	2
L04	0E00157A	Washer 3mm Collar	11
L05	0E00589A	Screw M3x6 Philips Pan Head (Bronze)	7
L06	0E00071A	Washer 3mm Fiber	1
L07	0E00607A	Screw M3x8 Philips Pan Head (3A)	3
L08	0E00660A	Screw M3x12 Philips Pan Head (3A)	1
A02-2	JA03232A	Chassis Ass'y (2/2) Silver	1
01	BA03903A	Power Supply P.C.B. Ass'y	1
02	JA03064A	Record Link Ass'y	1
03	JA03061A	Push Button Ass'y	1
04	JA03063A	Power Switch Ass'y	1
05	OJ03421A	Dolby NR P.C.B. Pad	2
06	OJ03417A	Meter Escutcheon	1
07	JA03230A	Meter Ass'y	1
08	BA03670A	Dolby NR P.C.B. Ass'y	1
09	BA03902A	Main P.C.B. Ass'y	1
10	JA03226A	Rear Panel Ass'y 120V	1
	JA03236A	Rear Panel Ass'y 220V	1
	JA03234A	Rear Panel Ass'y 220V/240V	1
	JA03237A	Rear Panel Ass'y 240V	1
	JA03239A	Rear Panel Ass'y 220V	1
	JA03238A	Rear Panel Ass'y 240V	1
	JA03233A	Rear Panel Ass'y 100V	1
11	0E00037A	Earth Lug B-5	2
12	0B08452A	Headphone Jack	1
L01	0E00606A	Screw M3x6 Philips Pan Head (3A)	3
L02	0E00612A	Screw M3x6 Philips Pan Head (2A)	2
L03	0E00505A	Screw M3x6 Philips Countersunk	2
L04	0E00157A	Washer 3mm Collar	11
L05	0E00589A	Screw M3x6 Philips Pan Head (Bronze)	7
L06	0E00071A	Washer 3mm Fiber	1
L07	0E00607A	Screw M3x8 Philips Pan Head (3A)	3
L08	0E00660A	Screw M3x12 Philips Pan Head (3A)	1

9. 3. 600II Mechanism Ass'y (A03)

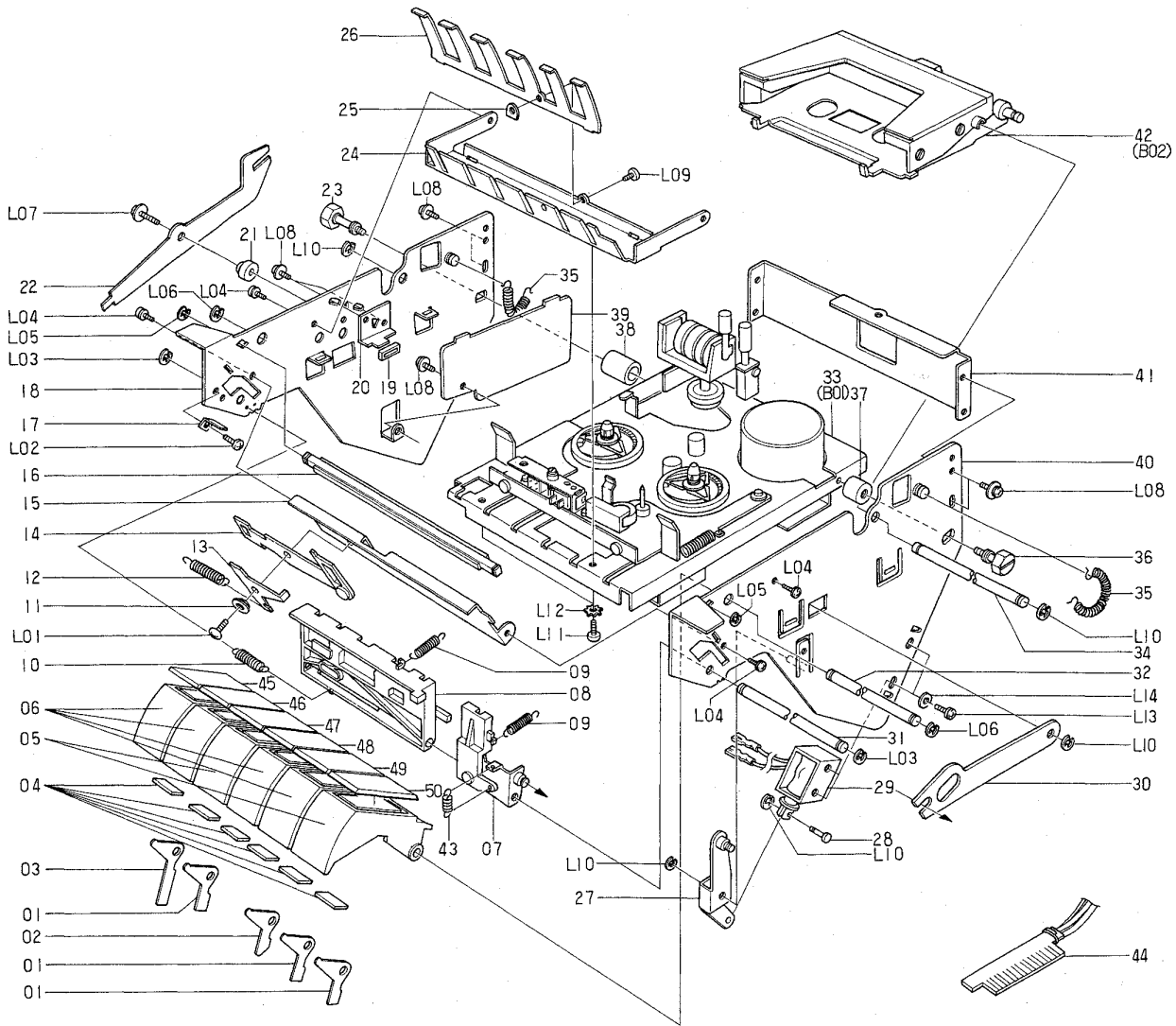

Fig. 9.3

Schematic Ref. No.	Part No.	Description	Q'ty	Schematic Ref. No.	Part No.	Description	Q'ty
A03	CA03310A	600II Mechanism Ass'y Black	1	11	0C03883A	Eject Linkage Collar	1
01	0C03892A	Button Cam B	3	12	0C03900A	Eject Arm Spring	1
02	0C03893A	Button Cam C	1	13	0C03882A	Lock Plate Slide Lever	1
03	0C03891A	Button Cam A	1	14	CA03257A	Eject Bar Ass'y	1
04	0C03894A	Button Plate	6	15	0C03881A	Front Hold Plate	1
05	CA03260B	Deck Button S Ass'y	2	16	CA03262A	Button Stopper Ass'y	1
06	CA03261B	Deck Button R Ass'y	4	17	0C03945A	Lock Plate Stopper	1
07	CA03263A	Pause Lock Plate Ass'y	1	18	CA03258A	Side Plate L Ass'y	1
08	0C03896B	Lock Plate	1	19	0C03885A	Lid Damper Rubber	1
09	0C03899A	Pause Lock Spring B	2	20	0C03884A	Lid Adjust Plate	1
10	0C03897A	Lock Plate Slide Spring	1	21	0C03905A	Lever Collar	1
				22	0C03904A	Eject Joint Bar	1

Schematic Ref. No.	Part No.	Description	Q'ty	Schematic Ref. No.	Part No.	Description	Q'ty
23	OC03887A	Side Plate L Bolt	1	13	OC03882A	Lock Plate Slide Lever	1
24	OC03878A	Button Guide	1	14	CA03257A	Eject Bar Ass'y	1
25	OC03880A	Button Spring Holder	1	15	OC03881A	Front Hold Plate	1
26	OC03879A	Button Spring	1	16	CA03262A	Button Stopper Ass'y	1
27	CA03265A	Shut-off Arm Ass'y	1	17	OC03945A	Lock Plate Stopper	1
28	OC03906A	Solenoid Pin	1	18	CA03258A	Side Plate L Ass'y	1
29	BA03727A	Solenoid Sub Ass'y	1	19	OC03885A	Lid Damper Rubber	1
30	OC03907A	Shut-off Bar	1	20	OC03884A	Lid Adjust Plate	1
31	OC03901A	Lock Shaft	1	21	OC03905A	Lever Collar	1
32	OC03895A	Button Shaft	1	22	OC03904A	Eject Joint Bar	1
33	CA03311A	Mechanism Ass'y (Serial No. A206.7 05001 and greater)	1	23	OC03887A	Side Plate L Bolt	1
	CA03256B	Mechanism Ass'y (Up to serial No. A206.7 05000)	1	24	OC03878A	Button Guide	1
34	OC03903A	Lid Shaft	1	25	OC03880A	Button Spring Holder	1
35	OC03902A	Lid Spring	2	26	OC03879A	Button Spring	1
36	OC03889A	Side Plate R Bolt	1	27	CA03265A	Shut-off Arm Ass'y	1
37	OC03888A	Side Plate R Collar	1	28	OC03906A	Solenoid Pin	1
38	OC03886A	Side Plate L Collar	1	29	BA03727A	Solenoid Sub Ass'y	1
39	BA03950A	Shut-off P.C.B. Ass'y (Serial No. A206.7 05001 and greater)	1	30	OC03907A	Shut-off Bar	1
	BA03722B	Shut-off P.C.B. Ass'y (Up to serial No. A206.7 05000)	1	31	OC03901A	Lock Shaft	1
40	CA03259A	Side Plate R Ass'y	1	32	OC03895A	Button Shaft	1
41	OC03890A	Rear Hold Plate	1	33	CA03311A	Mechanism Ass'y (Serial No. A206.7 05001 and greater)	1
42	CA03308A	Cassette Case Ass'y Black	1		CA03256B	Mechanism Ass'y (Up to serial No. A206.7 05000)	1
43	OC03898A	Pause Lock Spring	1	34	OC03903A	Lid Shaft	1
44	OB07551A	10P Plug Board	1	35	OC03902A	Lid Spring	2
45	OH03628A	Button Cover REC. Black	1	36	OC03889A	Side Plate R Bolt	1
46	OH03629A	Button Cover REW. Black	1	37	OC03888A	Side Plate R Collar	1
47	OH03630A	Button Cover STOP Black	1	38	OC03886A	Side Plate L Collar	1
48	OH03632A	Button Cover PLAY Black	1	39	BA03950A	Shut-off P.C.B. Ass'y (Serial No. A206.7 05001 and greater)	1
49	OH03631A	Button Cover F.F. Black	1		BA03722B	Shut-off P.C.B. Ass'y (Up to serial No. A206.7 05000)	1
50	OH03633A	Button Cover PAUSE Black	1	40	CA03259A	Side Plate R Ass'y	1
L01	OE00121A	Screw M2.6x6 Philips Pan Head	1	41	OC03890A	Rear Hold Plate	1
L02	OE00226A	Screw M2.6x4 Philips Pan Head	1	42	CA03307A	Cassette Case Ass'y Silver	1
L03	OE00181A	E-Ring 3mm	2	43	OC03898A	Pause Lock Spring	1
L04	OE00612A	Screw M3x6 Philips Pan Head (2A)	4	44	OB07551A	10P Plug Board	1
L05	OE00698A	E-Ring 2.5mm	2	45	OH03404B	Button Cover REC. Silver	1
L06	OE00134A	E-Ring 4mm	2	46	OH03405B	Button Cover REW. Silver	1
L07	OE00610A	Screw M3x12 Philips Pan Head(3A)	1	47	OH03406B	Button Cover STOP Silver	1
L08	OE00606A	Screw M3x6 Philips Pan Head (3A)	7	48	OH03407B	Button Cover PLAY Silver	1
L09	OE00166A	Screw M2x4 Cylinder Head	1	49	OH03408B	Button Cover F.F. Silver	1
L10	OE00222A	E-Ring 2mm	5	50	OH03409B	Button Cover PAUSE Silver	1
L11	OE00509A	Screw M3x6 Philips Pan Head	2	L01	OE00121A	Screw M2.6x6 Philips Pan Head	1
L12	OE00172A	Washer 3mm Toothed Lock	2	L02	OE00226A	Screw M2.6x4 Philips Pan Head	1
L13	OE00622A	Screw M3x5 Philips Pan Head (2A)	2	L03	OE00181A	E-Ring 3mm	2
L14	OE00597A	Washer 3mm	2	L04	OE00612A	Screw M3x6 Philips Pan Head (2A)	4
				L05	OE00698A	E-Ring 2.5mm	2
A03	CA03255B	600II Mechanism Ass'y Silver	1	L06	OE00134A	E-Ring 4mm	2
01	OC03892A	Button Cam B	3	L07	OE00610A	Screw M3x12 Philips Pan Head(3A)	1
02	OC03893A	Button Cam C	1	L08	OE00606A	Screw M3x6 Philips Pan Head (3A)	7
03	OC03891A	Button Cam A	1	L09	OE00166A	Screw M2x4 Cylinder Head	1
04	OC03894A	Button Plate	6	L10	OE00222A	E-Ring 2mm	5
05	CA03260B	Deck Button S Ass'y	2	L11	OE00509A	Screw M3x6 Philips Pan Head	2
06	CA03261B	Deck Button R Ass'y	4	L12	OE00172A	Washer 3mm Toothed Lock	2
07	CA03263A	Pause Lock Plate Ass'y	1	L13	OE00622A	Screw M3x5 Philips Pan Head (2A)	2
08	OC03896B	Lock Plate	1	L14	OE00597A	Washer 3mm	2
09	OC03899A	Pause Lock Spring B	2				
10	OC03897A	Lock Plate Slide Spring	1				
11	OC03883A	Eject Linkage Collar	1				
12	OC03900A	Eject Arm Spring	1				

9.4. Front Control Ass'y (A04)

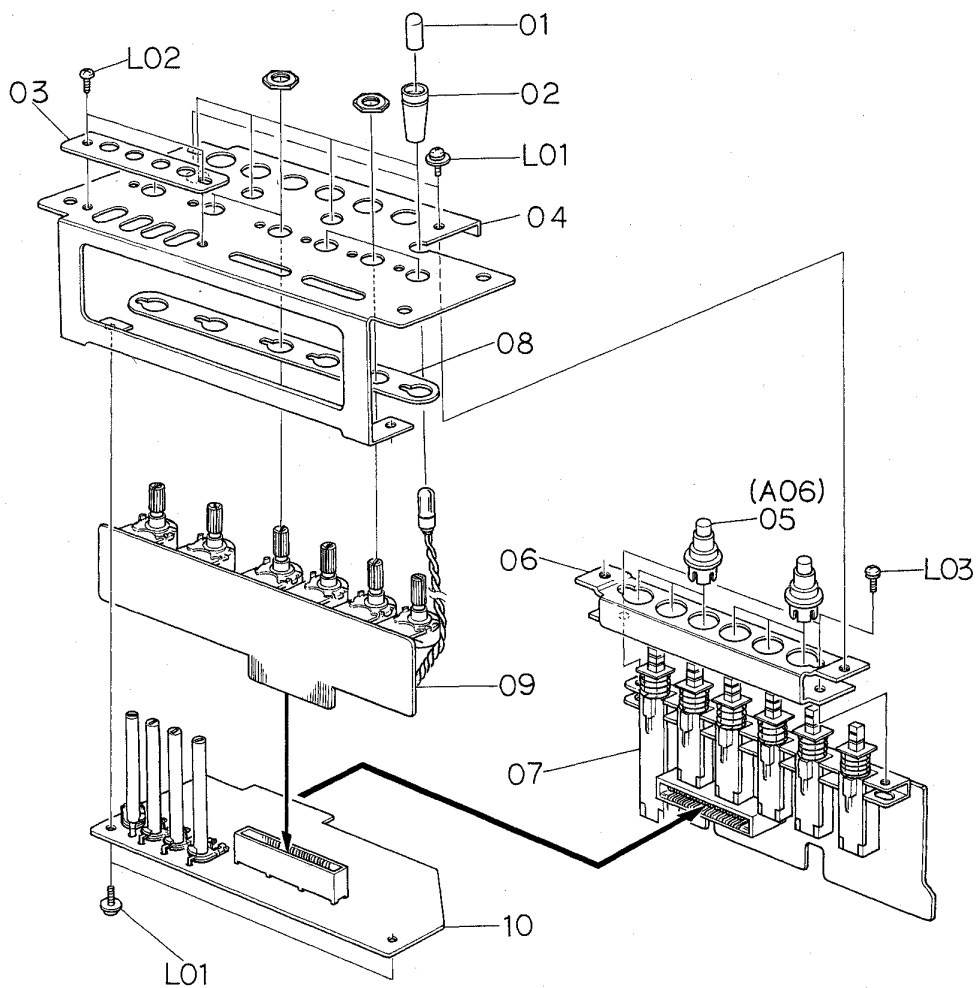

Fig. 9.4

9.5. Record Link Ass'y (A05)

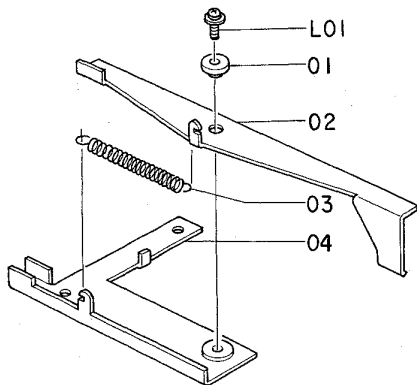

Fig. 9.5

9.6. Push Button Ass'y (A06)

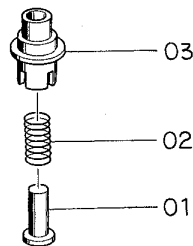

Fig. 9.6

Schematic Ref. No.	Part No.	Description	Q'ty
A04	JA03229A	Front Control Ass'y	1
01	0H03636A	Lamp Cap Orange	4
02	0B08458B	Lamp Holder	4
03	0J03792A	VR Holder	1
04	0J03790A	Switch Cover	1
05	JA03061A	Push Button Ass'y	6
06	0J03410C	Switch Holder	1
07	BA03899A	Switch P.C.B. Ass'y	1
08	0J03791A	Cal. Cover	1
09	BA03900A	Cal. P.C.B. A Ass'y	1
10	BA03901A	Cal. P.C.B. B Ass'y	1
L01	0E00606A	Screw M3x6 Philips Pan Head (3A)	4
L02	0E00226A	Screw M2.6x4 Philips Pan Head	2
L03	0E00612A	Screw M3x6 Philips Pan Head (2A)	2
A05	JA03064A	Record Link Ass'y	1
01	0J03396A	Record Link Collar	1
02	0J03420A	Record Link	1
03	0J03423A	Record Link Spring	1
04	0J03419A	Record Arm Chassis	1
L01	0E00607A	Screw M3x8 Philips Pan Head (3A)	1
A06	JA03061A	Push Button Ass'y	7
01	0J03413A	Push Button	1
02	0J03414A	Switch Spring	1
03	0J03412A	Push Button Flange	1

9.7. Rear Panel Ass'y (A07)

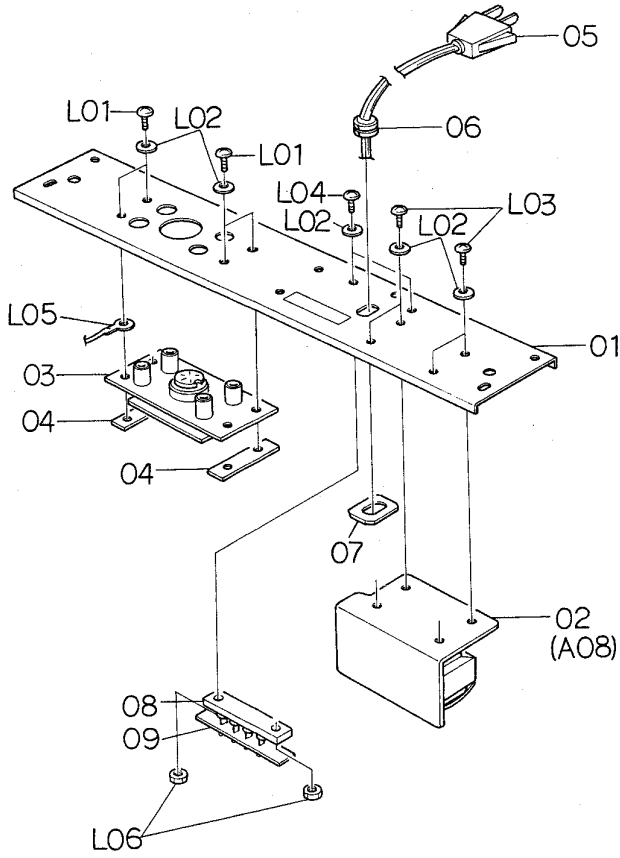

Fig. 9.7

9.8. Power Transformer Ass'y (A08)

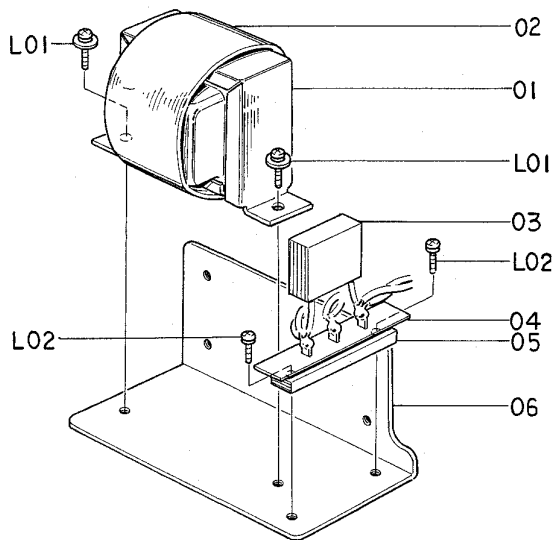

Fig. 9.8

9.9. Power Switch Ass'y (A09)

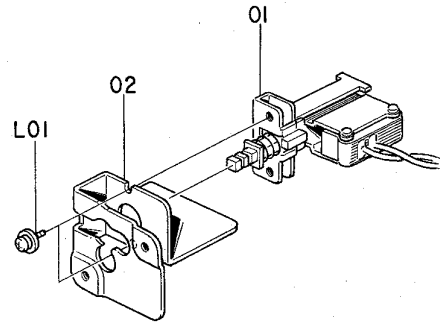

Fig. 9.9

9.10. Meter Ass'y (A10)

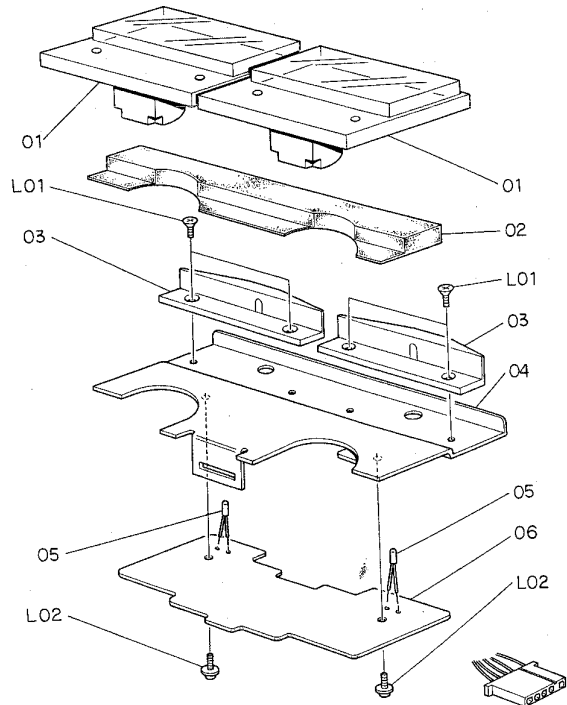

Fig. 9.10

Schematic Ref. No.	Part No.	Description	Q'ty	Schematic Ref. No.	Part No.	Description	Q'ty					
A07	JA03226A	Rear Panel Ass'y 120V	1	A09	JA03063A	Power Switch Ass'y	1					
	JA03236A	Rear Panel Ass'y 220V	1		01	0B07093U	Power Switch	1				
	JA03234A	Rear Panel Ass'y 220V/240V	1			0B07130U	Power Switch	1				
	JA03237A	Rear Panel Ass'y 240V	1				0J03408A	Power Switch Holder	1			
	JA03239A	Rear Panel Ass'y 220V	1					L01	0E00606A	Screw M3x6 Philips Pan Head (3A)	2	
	JA03238A	Rear Panel Ass'y 240V	1						A10	JA03230A	Meter Ass'y	1
	JA03233A	Rear Panel Ass'y 100V	1							01	0B08453A	Level Meter
01	JA03228A	Rear Panel Sub Ass'y	1	02							0M03424B	Meter Cushion
	02	JA03227A	Power Transformer Ass'y 120V		1						03	0J03418A
02	JA03241A	Power Transformer Ass'y 220V	1	04	JA03052A	Meter Holder Sub Ass'y						1
	JA03242A	Power Transformer Ass'y 240V	1		05	0B08155A	Meter Lamp				2	
03	JA03240A	Power Transformer Ass'y 100V	1	06		BA03902A	Meter P.C.B. Ass'y	1				
	03	BA03726A	DIN Pin Jack P.C.B. Ass'y		1	L01	0E00602A	Screw M3x4 Philips Countersunk	4			
04	0J03277A	Metal Seat Nut	2	L02	0E00606A		Screw M3x6 Philips Pan Head (3A)	2				
	05	0B08350A	Power Cord 120V		1							
05	0B08149U	Power Cord 220V	1									
	0B08348A	Power Cord 240V	1									
	0B08093A	Power Cord 220V	1									
	0B08266A	Power Cord 240V	1									
	0B08219B	Power Cord 100V	1									
	06	0B08037U	Cord Bushing C	1								
		0B08325U	Cord Bushing E	1								
07	0B08351A	Cord Bushing	1									
	0A03154B	Cord Spacer	1									
08	0B08024U	3P Terminal Strip	1									
09	0B08410A	3P Terminal Insulator	1									
L01	0E00588A	Screw M3x8 Philips Pan Head (Bronze)	4									
L02	0E00157A	Washer 3mm Collar	10									
L03	0E00589A	Screw M3x6 Philips Pan Head (Bronze)	4									
L04	0E00757A	Screw M3x6 Philips Pan Head (Plastics)	2									
L05	0E00037A	Earth Lug B-5	1									
L06	0E00758A	Nut Hex. M3 Plastics	2									
A08	JA03227A	Power Transformer Ass'y 120V	1									
	JA03241A	Power Transformer Ass'y 220V	1									
	JA03242A	Power Transformer Ass'y 240V	1									
	JA03240A	Power Transformer Ass'y 100V	1									
01	0B06575A	Power Transformer 120V	1									
	0B06576A	Power Transformer 220V/240V	1									
	0B06579A	Power Transformer 100V	1									
02	0J03051A	Transformer Shield Plate	1									
	0B08342A	Spark Killer 120V	1									
03	0B07096A	Spark Killer 220V	1									
	0B08240A	Spark Killer 240V	1									
	0B08363A	Spark Killer 100V	1									
	0B08410A	3P Terminal Insulator	1									
04	0B08024U	3P Terminal Strip	1									
05	0B08024U	3P Terminal Strip	1									
06	0J03422A	Transformer Holder	1									
L01	0E00606A	Screw M3x6 Philips Pan Head (3A)	2									
L02	0E00510A	Screw M3x8 Philips Pan Head (2A)	2									
	0E00810A	Screw M3x8 Philips Pan Head (Plastics)	2									

9.11. Mechanism Ass'y

9.11.1. Mechanism Ass'y (1/2) (B01-1)

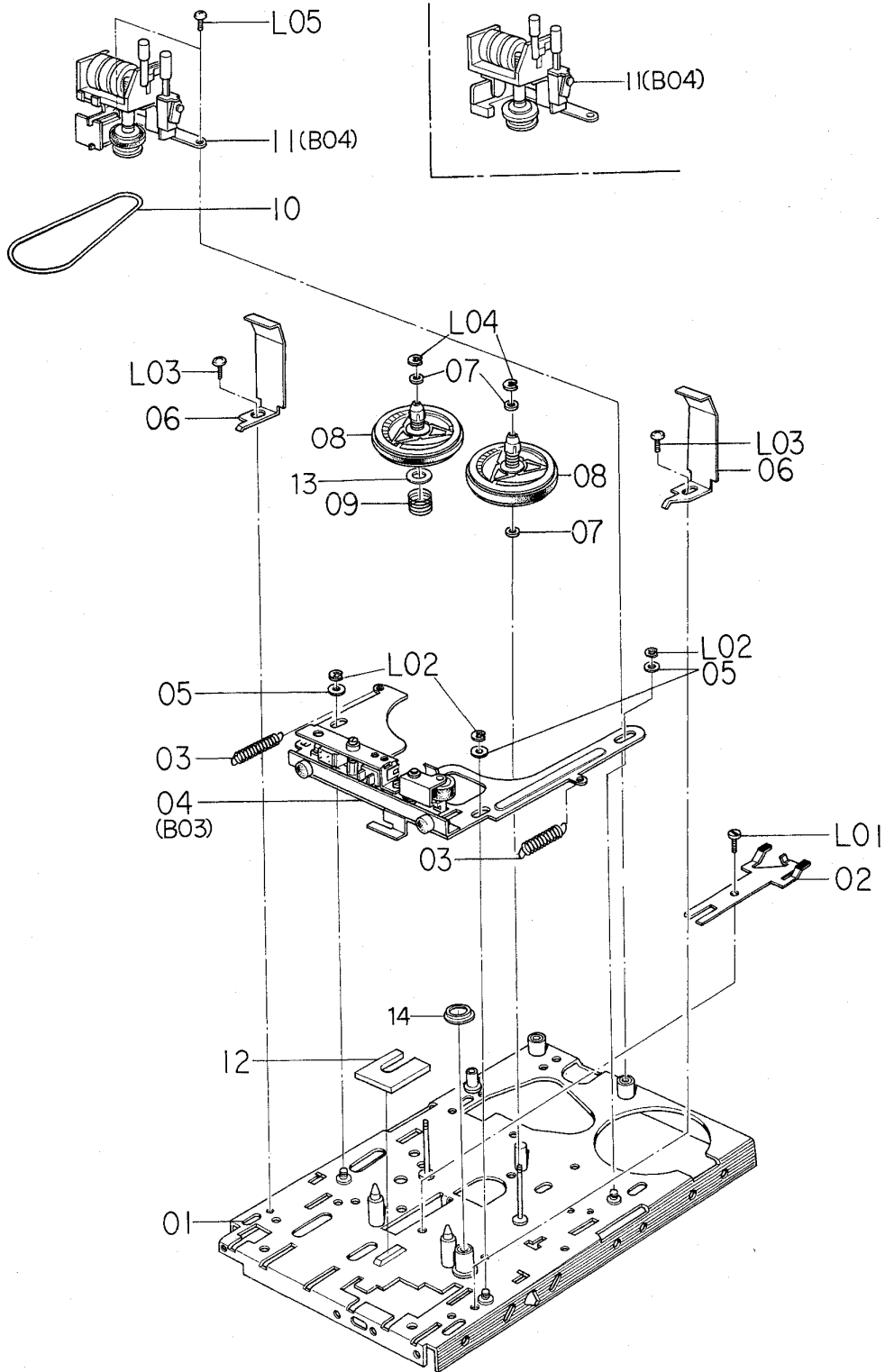

Fig. 9.11.1

Schematic Ref. No.	Part No.	Description	Q'ty
B01-1	CA03311A	Mechanism Ass'y (1/2) (Serial No. A206.7 05001 and greater)	1
01	CA03266B	Mechanism Chassis B Ass'y	1
02	CA03140A	Brake Ass'y	1
03	0C03694B	Base Return Spring	2
04	CA03267B	Head Base B Ass'y	1
05	0C06243A	Washer W4-8-0.2F	3
06	0C03908B	Cassette Guide	2
07	0C03613A	Washer 1.6mm Plastics	3
08	CA03300A	Reel Hub C Ass'y	2
09	0C03612C	Back Tension Spring	1
10	0C03651A	Counter Belt E	1
11	CA03305A	Counter Holder Ass'y	1
12	0C03863A	Head Base Spacer	1
13	0C03994A	Supply Mylar Washer	1
14	0C04004A	Sleeve Ring	1
L01	0E00166A	Screw M2x4 Cylinder Head	1
L02	0E00181A	E-Ring 3mm	3
L03	0E00226A	Screw M2.6x4 Philips Pan Head	2
L04	0E00165A	E-Ring 1.2mm	2
L05	0E00219A	Screw M2.6x5 Philips Pan Head	2
B01-1	CA03256B	Mechanism Ass'y (1/2) (Up to serial No. A206.7 05000)	1
01	CA03266B	Mechanism Chassis B Ass'y	1
02	CA03140A	Brake Ass'y	1
03	0C03694B	Base Return Spring	2
04	CA03267B	Head Base B Ass'y	1
05	0C06243A	Washer W4-8-0.2F	3
06	0C03908B	Cassette Guide	2
07	0C03613A	Washer 1.6mm Plastics	3
08	CA03300A	Reel Hub C Ass'y	2
09	0C03612C	Back Tension Spring	1
10	0C03651A	Counter Belt E	1
11	CA03271A	Counter Holder Ass'y	1
12	0C03863A	Head Base Spacer	1
13	0C03994A	Supply Mylar Washer	1
14	0C04004A	Sleeve Ring	1
L01	0E00166A	Screw M2x4 Cylinder Head	1
L02	0E00181A	E-Ring 3mm	3
L03	0E00226A	Screw M2.6x4 Philips Pan Head	2
L04	0E00165A	E-Ring 1.2mm	2
L05	0E00219A	Screw M2.6x5 Philips Pan Head	2

9.11.2. Mechanism Ass'y (2/2) (B01-2)

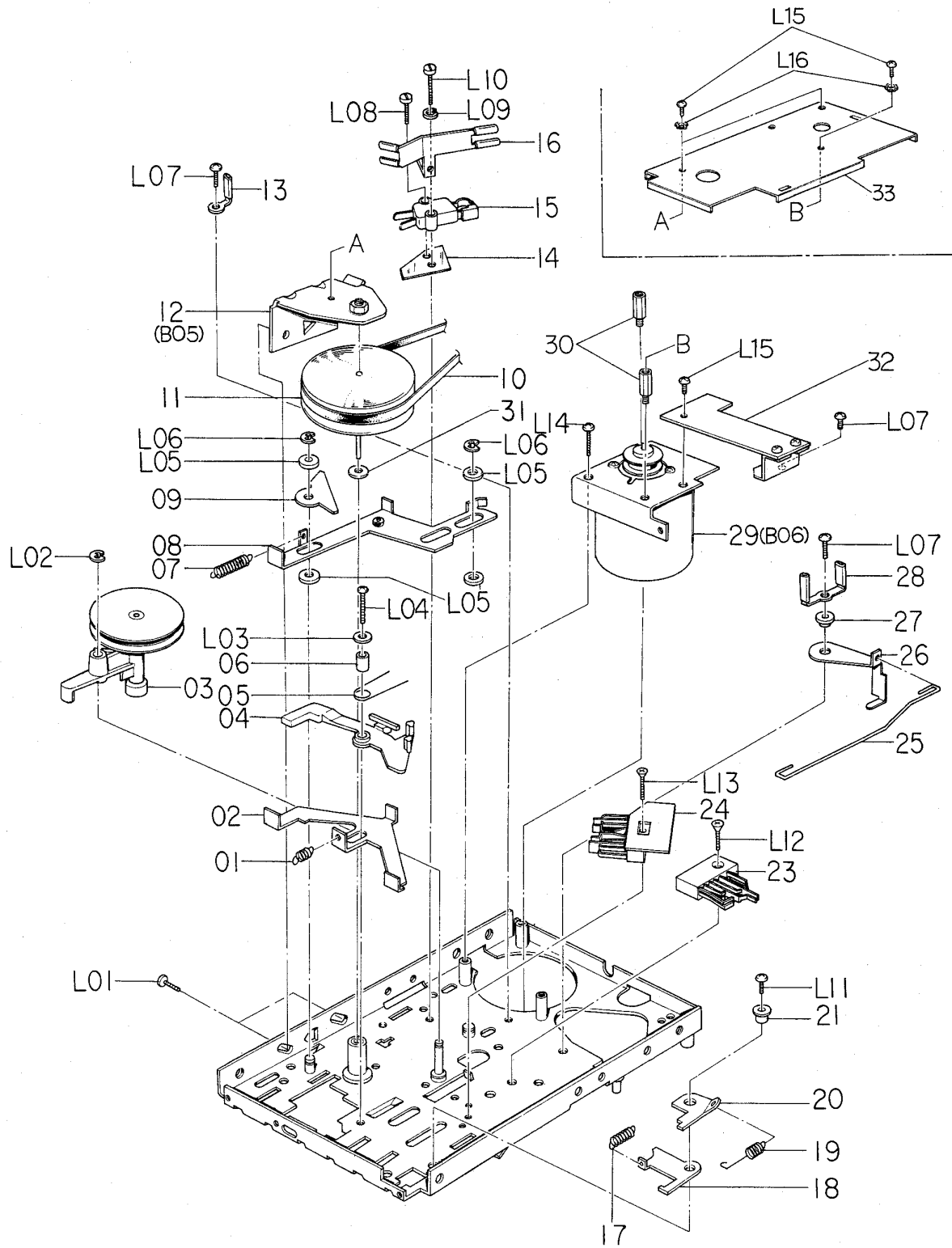

Fig. 9.11.2

Schematic Ref. No.	Part No.	Description	Q'ty
B01-2	CA03311A	Mechanism Ass'y (2/2) Serial No. A206.7 05001 and greater)	1
01	0C03649A	See-Saw Arm Spring	1
02	0C03647B	See-Saw Arm	1
03	CA03301B	Idler Pulley Ass'y	1
04	0C03646A	FRP Lever B	1
05	0C03650B	Lever Spring	1
06	0C03648A	See-Saw Arm Pipe	1
07	0C03748A	Slide Plate Spring	1
08	0C03744B	Pause Slide Plate	1
09	0C03746C	Pause Bar	1
10	0C03668A	Driving Belt	1
11	CA03225A	Flywheel B Ass'y	1
12	CA03226A	Flywheel Holder C Ass'y	1
13	0C03591A	Cord Holder	1
14	0C03800A	Pause Switch Mylar	1
15	0C03743A	Pause Switch	1
16	0C03799E	Belt Guide	1
17	0C03774A	Base Cam Spring	1
18	0C03773C	Base Cam	1
19	0C03791A	Record Lock Spring B	1
20	0C03652C	Record Lock B	1
21	0C03775C	Base Cam Shaft	1
22	0C03805B	Stud Collar B	3
23	CA03141A	Mute Switch Ass'y	1
24	CA03231A	Start Switch C Ass'y	1
25	0C03704A	Record Sensor Linkage B	1
26	0C03909A	Record Sensor B	1
27	0C03546A	Record Lock Shaft	1
28	0B03067A	Bind Holder	1
29	CA03253B	MHX Motor Ass'y B	1
30	0C03971B	Shield Cover Stud	2
31	0C03174A	Washer 2.1mm Plastics	1
32	0B08204A	MHX Governor B	1
33	0C03970B	Shield Cover	1
L01	0E00226A	Screw M2.6x4 Philips Pan Head	2
L02	0E00222A	E-Ring 2mm	1
L03	0E00142A	Washer 2.6mm	1
L04	0E00229A	Screw M2.6x10 Philips Pan Head	1
L05	0E00031A	Washer 4mm	4
L06	0E00181A	E-Ring 3mm	2
L07	0E00228A	Screw M2.6x6 Philips Pan Head (FT)	3
L08	0E00004A	Screw M2x8 Cylinder Head	1
L09	0E00025A	Washer 2mm Spring	1
L10	0E00218A	Screw M2x10 Cylinder Head	1
L11	0E00231A	Screw M2.6x8 Philips Pan Head (FT)	1
L12	0E00008A	Screw M2.6x8 Philips Countersunk	1
L13	0E00223A	Screw M2x10 Philips Countersunk	1
L14	0E00220A	Screw M2.6x8 Philips Pan Head	3
L15	0E00219A	Screw M2.6x5 Philips Pan Head	3
L16	0E00233A	Washer 2.6mm Toothed Lock	3
B01-2	CA03256B	Mechanism Ass'y (2/2) (Up to serial No. A206.7 05000)	1
Note:	Parts are the same as CA03311A Mechanism Ass'y (2/2)		

9.12. Cassette Case Ass'y (B02)

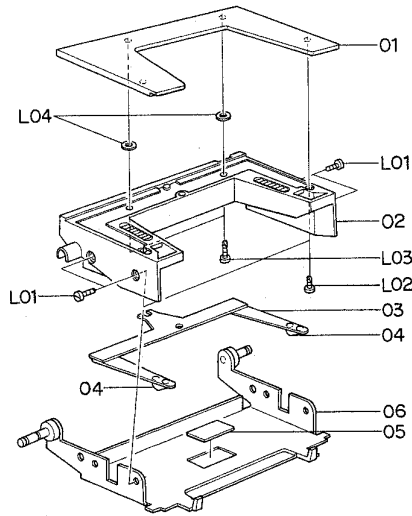

Fig. 9.12

9.13. Head Base B Ass'y (B03)

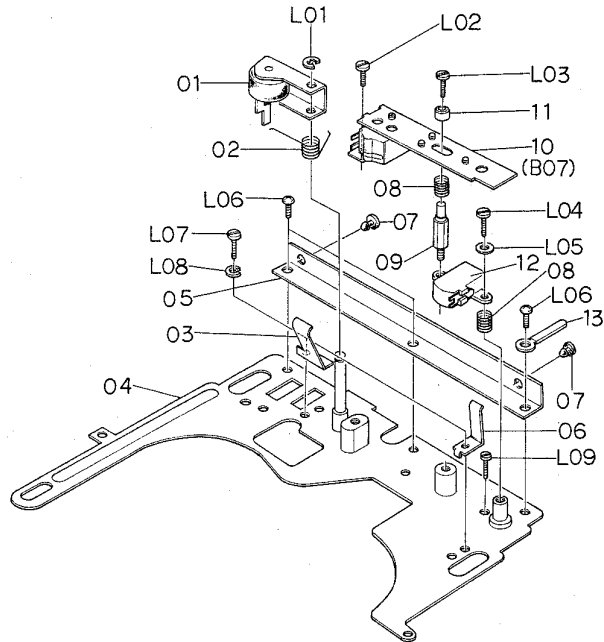

Fig. 9.13

9.15. Flywheel Holder C Ass'y (B05)

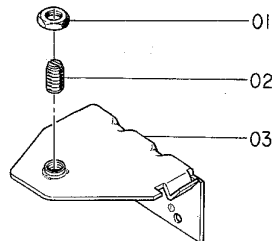

Fig. 9.15

9.14. Counter Holder Ass'y (B04)

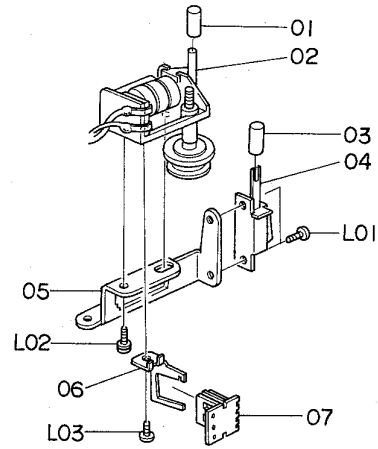

Fig. 9.14.1 Serial No. A206.7 05001 and greater (Hall IC System)

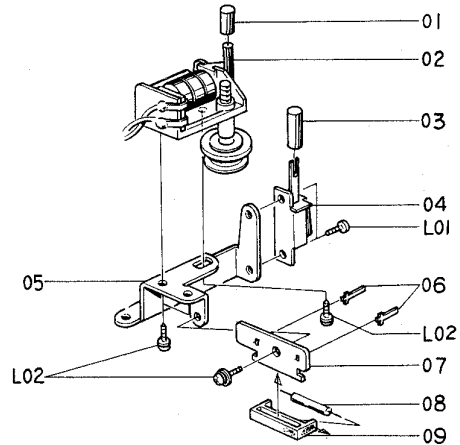

Fig. 9.14.2 Up to Serial No. A206.7 05000 (Reed Switch System)

9.16. MHX Motor Ass'y B (B06)

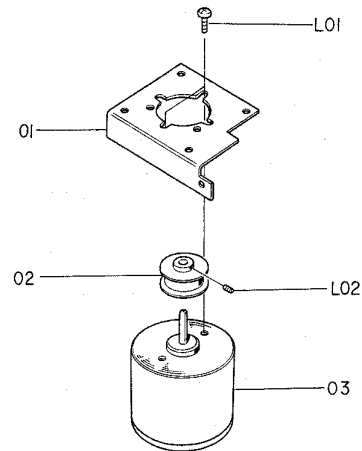

Fig. 9.16

9.17. Record/Playback Head Ass'y (B07)

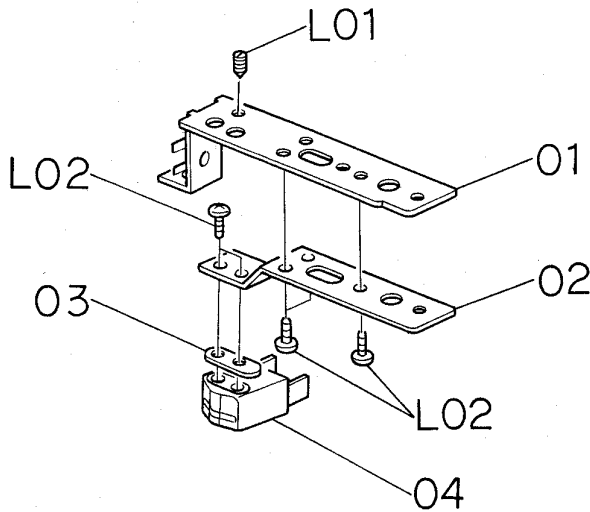
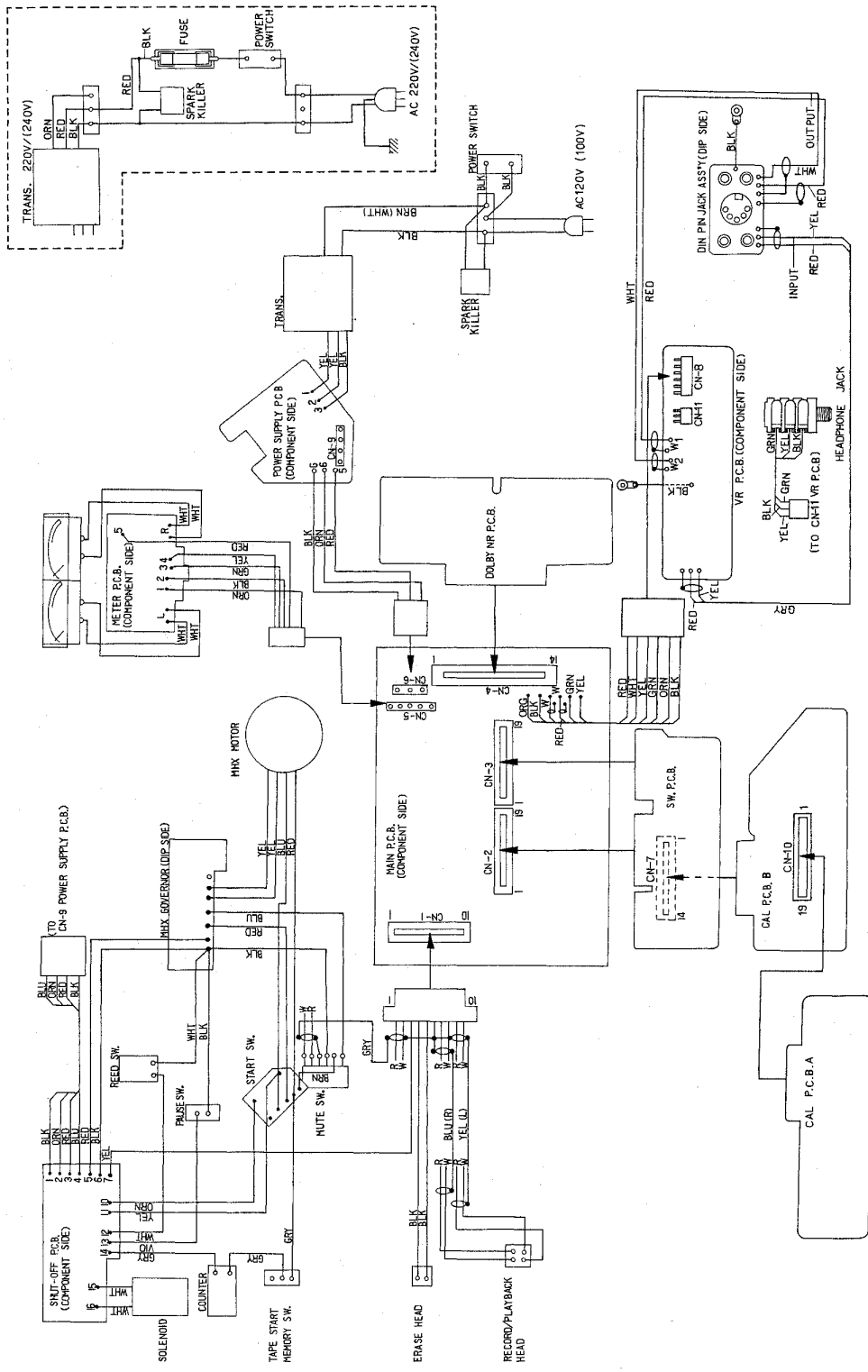

Fig. 9.17

Schematic Ref. No.	Part No.	Description	Q'ty
12	0C03862A	Erase Head	1
13	0C03996A	Cord Holder A	1
L01	0E00042A	E-Ring 1.5mm	1
L02	0E00166A	Screw M2x4 Cylinder Head	1
L03	0E00004A	Screw M2x8 Cylinder Head	1
L04	0E00185A	Screw M2x6 Cylinder Head	1
L05	0E00029A	Washer 2mm	1
L06	0E00120A	Screw M2.6x3 Philips Pan Head	3
L07	0E00002A	Screw M2x3 Cylinder Head	2
L08	0E00025A	Washer 2mm Spring	2
L09	0E00218A	Screw M2x10 Cylinder Head	1
B04	CA03305A	Counter Holder Ass'y (Serial No. A206.7 05001 and greater)	1
01	0C03933A	Counter Knob	1
02	CA03309A	Tape Counter Sub Ass'y	1
03	0C03934A	Memory Switch Knob	1
04	0B07051A	Memory Switch	1
05	0C03931B	Counter Holder	1
06	0C04006B	Hall IC Bracket	1
07	BA03951A	Hall IC P.C.B. Ass'y	1
L01	0E00166A	Screw M2x4 Cylinder Head	2
L02	0E00612A	Screw M3x6 Philips Pan Head (2A)	2
L03	0E00746A	Screw M2x6 Philips Binding Head	1
B04	CA03271A	Counter Holder Ass'y (Up to serial No. A206.7 05000)	1
01	0C03933A	Counter Knob	1
02	CA03279A	Tape Counter Ass'y	1
03	0C03934A	Memory Switch Knob	1
04	0B07051A	Memory Switch	1
05	0C03931A	Counter Holder	1
06	0B03924A	Test Pin	2
07	0B07640B	Reed Switch P.C.B.	1
08	0B03803A	Reed Switch	1
09	0C03932A	Reed Switch Holder	1
L01	0E00166A	Screw M2x4 Cylinder Head	2
L02	0E00612A	Screw M3x6 Philips Pan Head (2A)	4
B05	CA03226B	Flywheel Holder C Ass'y	1
01	0C03857A	Lock Nut	1
02	CA03281A	Thrust Screw Ass'y	1
03	CA03280A	Flywheel Holder C Sub Ass'y	1
B06	CA03253B	MHX Motor Ass'y B	1
01	0C03976A	Motor Bracket C	1
02	0C03770B	Motor Pulley JA	1
03	0C03950A	MHX Motor B	1
L01	0E00120A	Screw M2.6x3 Philips Pan Head	2
L02	0E00224A	Screw M2x3 Cup Point	1
B07	CA03303A	Record/Playback Head Ass'y	1
01	GA02016A	Head Holder Ass'y	1
02	0G01201B	Head Height Adjust Flat Spring	1
03	0G01100B	Head Holder Spacer	1
04	GA02012B	RP-53 Record/Playback Head	1
L01	0E00809A	Screw M2x6 Cup Point	1
L02	0E00783A	Screw M2x3 Philips Pan Head (Bronze)	5

Schematic Ref. No.	Part No.	Description	Q'ty
B02	CA03308A	Cassette Case Ass'y Black	1
01	0H03581B	Lid Cover Black	1
02	0C04002C	Cassette Lid	1
03	CA03274A	SP Base Plate Ass'y	1
04	0C03924A	Cassette Stabilizer	2
05	0M03638B	Silver Plate 600	1
06	CA03273B	Cassette Well Ass'y	1
L01	0E00699A	Screw M2x4 Cylinder Head	4
L02	0E00814A	ST Screw M2x4 Philips Pan Head (JCIS)	4
B02	CA03307A	Cassette Case Ass'y Silver	1
01	0H03578B	Lid Cover Silver	1
02	0C04002C	Cassette Lid	1
03	CA03274A	SP Base Plate Ass'y	1
04	0C03924A	Cassette Stabilizer	2
05	0M03638B	Silver Plate 600	1
06	CA03273B	Cassette Well Ass'y	1
L01	0E00699A	Screw M2x4 Cylinder Head	4
L02	0E00814A	ST Screw M2x4 Philips Pan Head (JCIS)	4
B03	CA03267B	Head Base B Ass'y	1
01	CA03276B	Pressure Roller B Ass'y	1
02	0C03758B	Pressure Roller Spring B	1
03	0C03691B	Cassette Retainer Spring R	1
04	CA03275B	Head Base B Sub Ass'y	1
05	0C03942A	Base Angle B	1
06	0C03690B	Cassette Retainer Spring L	1
07	0C03767A	Base Stopper Rubber	1
08	0C03999A	Azimuth Adjust Spring	2
09	0C04001A	Adjust Stud	1
10	CA03303A	Record/Playback Head Ass'y	1
11	0C04000A	Bushing	1

10. WIRING DIAGRAM



Note: Table of wire colors
 BLK - Black GRY - Gray BRN - Brown BLU - Blue GRN - Green
 YEL - Yellow ORN - Orange RED - Red WHT - White

Fig. 10

11. EQ. AMP. FREQUENCY RESPONSE

11.1. Playback Frequency Response

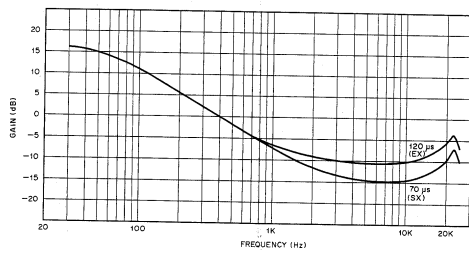

Fig. 11.1

11.2. Record Current Frequency Response

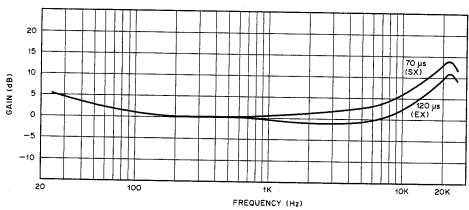

Fig. 11.2

12. BLOCK DIAGRAM

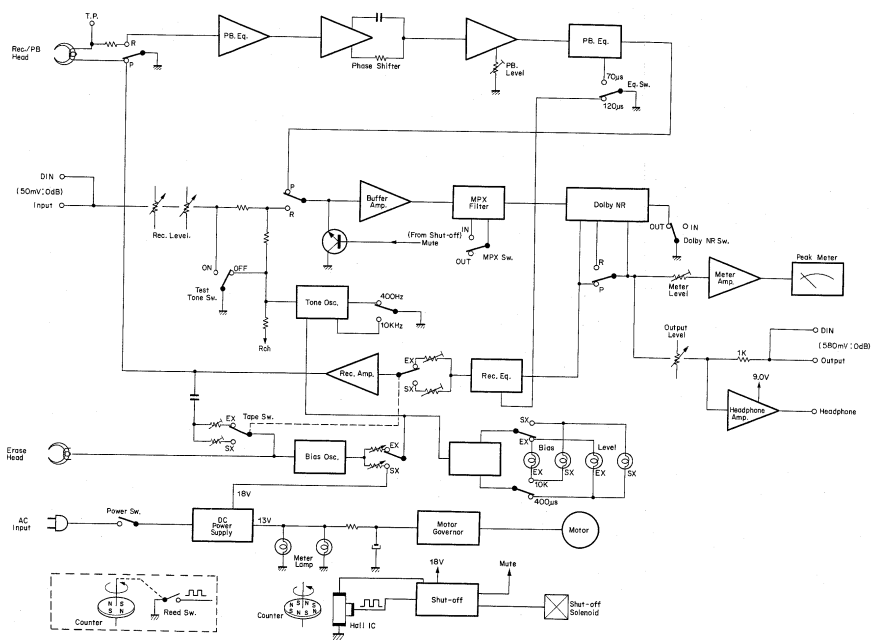
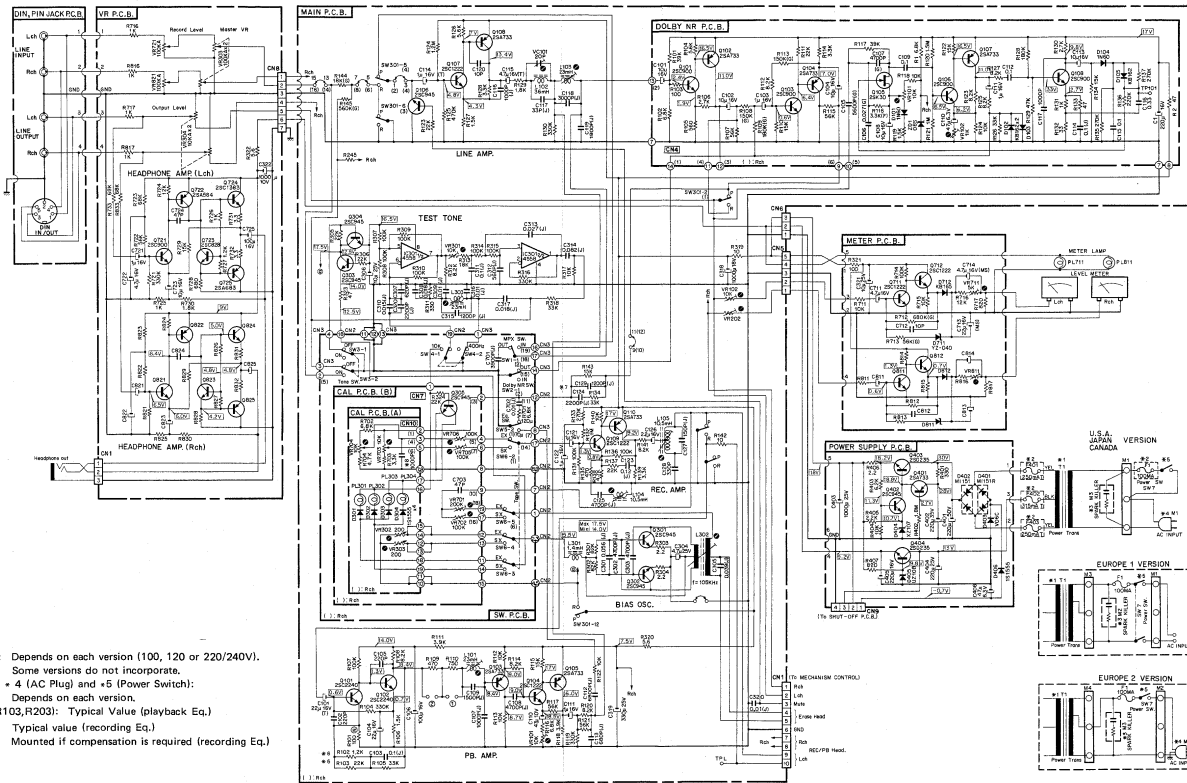

Fig. 12

13. SCHEMATIC DIAGRAM

13.1. Amplifier



- 1 (Transformer): Depends on each version (100, 120 or 220/240V).
- 2 (Fuse) Some versions do not incorporate.
- 3 (Spark Killer), • 4 (AC Plug) and 15 (Power Switch): Depends on each version.
- 6 (R102, R202, R103, R203): Typical Value (playback Eq.)
- 7 (C129, C229): Typical value (recording Eq.)
- 8 (C): Mounted if compensation is required (recording Eq.)

Notes:

- (1) () shows R channel's terminal No.
- (2) R channel circuits are omitted when R channel circuits are equal to the L channel.
- (3) On main P.C.B. and Dolby NR P.C.B., part reference Nos. 100–199 show L channel's parts and 200–299 show R channel's parts.
- (4) For example R101 is an L channel's resistor and omitted R201 is an R channel's resistor.

Fig. 13.1

- (3) On meter P.C.B. and VR P.C.B., part reference Nos. 700–799 show L channel's parts and 800–899 show R channel's.
- (4) On Cal. A P.C.B., Cal. B P.C.B. and switch P.C.B., part reference Nos. 700–799 show L channel's parts and omitted 800–899 show R channel's.
- (5) Part reference Nos. 300–399, 400–499 show common parts for both channels.

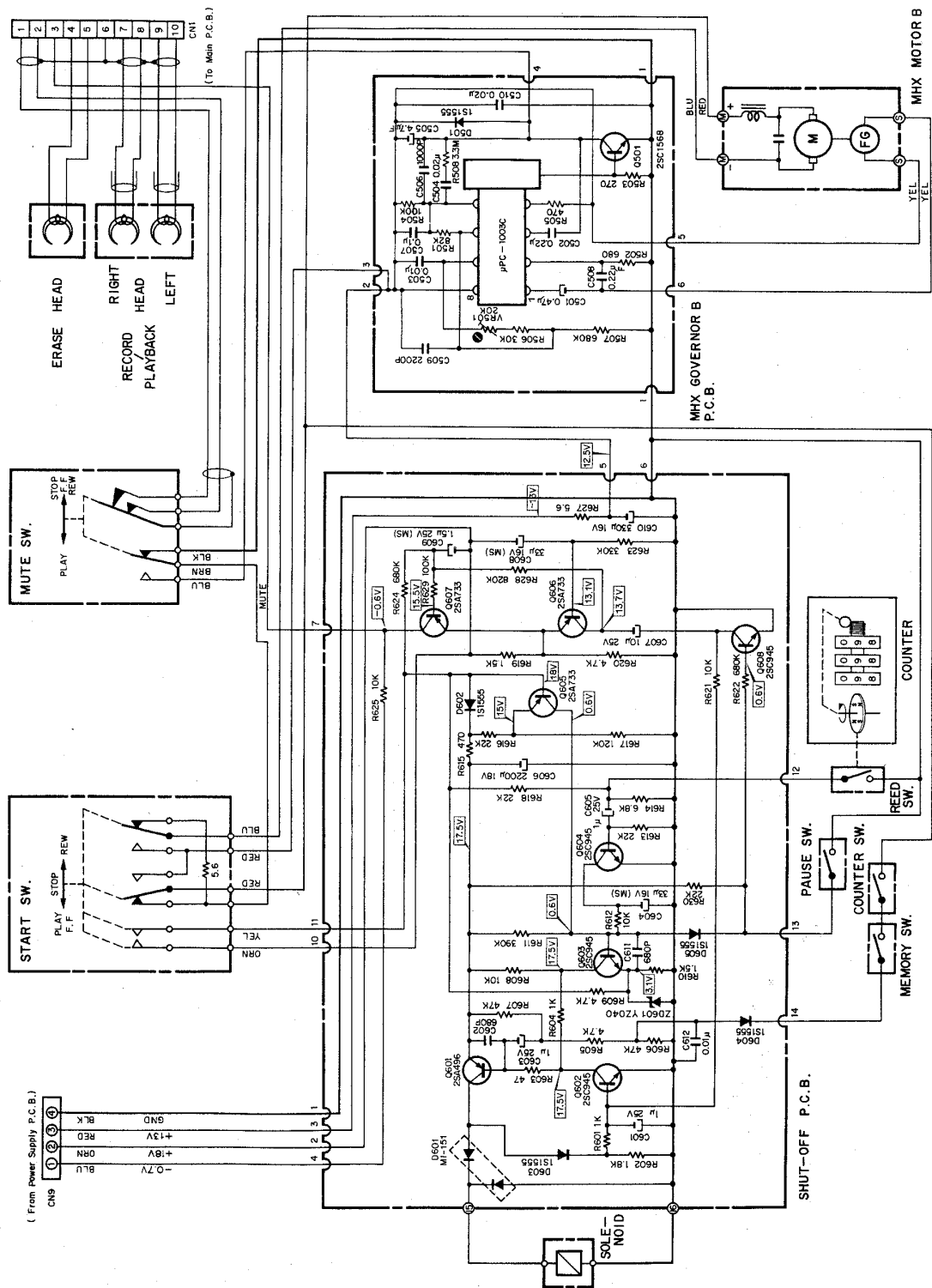

Fig. 13.3 Up to serial No. A206.7 05000 (Reed Switch System)

14. TROUBLESHOOTING

14.1. Note

- (1) Check to insure whether the outputs + 18 V, + 9 V and -0.7 V (approximately) of the power supply are correct.
- (2) When a check is made on Amplifier, etc. by means of an extension cord, re-adjustment shall be made without fail after final installation to the model chassis.

The check without removal of an extension cord will cause inaccurate adjustments.

- (3) When an adjustment is made on 19 kHz MPX filter, Bias trap coil, Peaking coil and/or Bias frequency, remove Meters and Meter Holder before start of adjustment.
- (4) Either Nakamichi SX or EXII tape shall be used while adjustment (particularly while adjustment of bias and record/playback level).

Should another different branded tape be used in its place, the machine shall previously be adjusted according to each of the actual tapes in use.

However, if a low quality tape should be used, optimum quality of machine will not be obtained (such as Distortion, Signal to Noise Ratio, Dynamic Range, etc. will be deteriorated).

- (5) Depress the pause button during Play or Fast-forward. The tape could be stopped but the motor is still rotating. Depress the pause button during rewind, and this time the motor and tape are always in rewind mode (the tape keeps rotating).
- (6) When Flywheel is replaced, clean the Capstan before start of the operation (with alcohol-dipped cloth).

14.2. Troubleshooting

14.2.1. Motor does not rotate:

- (1) Defective Motor.
- (2) Defective Motor Governor.
- (3) Defective Start Switch Ass'y.
- (4) Defective Mute Switch Ass'y.
- (5) Wire between Motor and Motor Governor is cut.
- (6) Wire between Motor Governor and Start Switch Ass'y is cut, etc.
- (7) + 13 V is not being supplied to the Motor Governor.

14.2.2. No power transmission:

- (1) Defective Power Cord.
- (2) Defective Power Switch.
- (3) Defective Power Transformer.
- (4) Defective DC Power Supply Circuit.
- (5) Defective Voltage Select Switch.

14.2.3. Sound is distorted:

- (1) Incorrect adjustment of Bias against tape.
- (2) Record/Playback Head is dirty.
- (3) Defective cassette tape.
- (4) Record/Playback Head is magnetized.
- (5) Weak Bias oscillation or does not oscillate.
- (6) Defective Record/Playback Head.
- (7) Excessively high level at Record/Playback.

14.2.4. High Frequency is deteriorated while playback:

- (1) Incorrect adjustment of Record/Playback Head azimuth.
- (2) Record/Playback Head is dirty.
- (3) Record/Playback Head is magnetized.
- (4) Excessive Wow/Flutter.
- (5) Inaccurate tape travel.
- (6) Defective Record/Playback Head.

14.2.5. High Frequency is deteriorated while record/playback:

- (1) Incorrect adjustment of Bias against tape (excessive bias current to the record/playback head).
- (2) Defective cassette tape.
- (3) Defective Record/Playback Head.

14.2.6. Does not play back:

- (1) Record/Playback Head is dirty.
- (2) Record/Playback Head is defective (open circuit or short circuit).
- (3) Defective Playback Amplifier.
- (4) Mute is not released.
- (5) Defective Mute Switch.
- (6) Defective Dolby NR Circuit.
- (7) Defective Output Buffer Amplifier.
- (8) Defective Record Switch.
- (9) Defective Output Jack.
- (10) Wire between Record/Playback Head and Playback Amplifier is cut.

14.2.7. Does not record:

- (1) Defective Bias Circuit.
- (2) Defective Erase Head (open circuit or short circuit).
- (3) Defective Record/Playback Head (open circuit or short circuit).
- (4) Record/Playback Head is dirty.
- (5) Defective Dolby NR Circuit.
- (6) Mute is not released.
- (7) Defective Record Amplifier.
- (8) Defective Record Switch.
- (9) Defective Record Link Ass'y.
- (10) Wire between Record/Playback Head and Record Amplifier is cut.
- (11) Defective Input Amplifier and/or Input Jack.
- (12) Inaccurate tape travel.

14.2.8. Excessive Wow/Flutter:

- (1) Defective Flywheel Ass'y.
- (2) Defective Motor.
- (3) Defective Motor Governor.
- (4) Defective Drive Belt.
- (5) Defective Pressure Roller Ass'y.
- (6) Defective Idler Pulley Ass'y.
- (7) Slippage between Pressure Roller and tape.
- (8) No clearance between Flywheel Ass'y and Flywheel Holder Ass'y.
- (9) Defective Cassette Tape (hard to rotate).
- (10) Defective Tape Counter (hard to rotate or sticky, etc.).
- (11) Excessive Back-tension.
- (12) Irregular Take-up Torque.

14.2.9. Does not erase or incomplete erasure:

- (1) Erase Head is dirty.
- (2) Defective Erase Head (open circuit or short circuit).
- (3) Inaccurate tape travel.
- (4) Weak Bias oscillation or does not oscillate.
- (5) Excessively high frequency of Bias oscillator.
- (6) Wire between Erase Head and Bias oscillator is cut.

14.2.10. Auto shut-off does not work at end of tape:

- (1) Defective Auto Shut-off Detector.
- (2) Defective Auto Shut-off Driver.
- (3) Defective Solenoid Driver.
- (4) Defective Deck Button (hard to operate).
- (5) Wire between Solenoid and Driver is cut.
- (6) Incorrect adjustment of Solenoid.

14.2.11. Auto Shut-off activates at position other than tape end:

- (1) Defective Auto Shut-off Detector.
- (2) Defective Auto Shut-off Driver.
- (3) Defective Solenoid Driver.
- (4) Defective Counter Ass'y.
- (5) Defective Counter Belt.
- (6) Defective Cassette Tape (hard to rotate).

14.2.12. Meters do not flutter:

- (1) Defective Meter (open circuit or short circuit).
- (2) Defective Meter Circuit.
- (3) Wire between Meter and Meter Circuit is cut.
- (4) Tape does not play back (in playback mode).
- (5) Meter lead is shorted.
- (6) Defective Input Amplifier.

14.2.13. Defective tape travel:

- (1) Record/Playback Head is misaligned against Capstan.
- (2) Pressure Roller is misaligned against Capstan.
- (3) Excessive Take-up Torque.
- (4) Pressure of Pressure Roller is weak.
- (5) Erase Head is misaligned against Capstan.
- (6) Defective Capstan (bent, etc.).
- (7) Defective Capstan Flange (bent, etc.).
- (8) Reference Pin is bent.
- (9) Head Base is bent.
- (10) Incorrect adjustment of Record/Playback Head position.
- (11) Defective Erase Head.
- (12) Defective Pressure Roller Ass'y.
- (13) Excessive clearance of Pressure Roller Ass'y.
- (14) Incorrect adjustment of Tape Guide height (Erase Head, Record/Playback Head).

14.2.14. Pause button does not release:

- (1) Defective Shut-off Solenoid.
- (2) Defective Solenoid Driver.
- (3) Defective Solenoid Linkage.

14.2.15. Tape does not rotate:

- (1) Defective Motor.
- (2) Defective Motor Governor.
- (3) Defective Drive Belt.
- (4) Drive Belt is out of place.
- (5) Defective Reel Hub Ass'y.
- (6) Defective cassette tape (hard to rotate).
- (7) Incorrect loading of cassette tape.
- (8) Pressure Roller is not in contact with Capstan.

14.2.16. Drive Belt is out of place:

- (1) Motor is misaligned.
- (2) Idler Pulley Ass'y is misaligned.
- (3) Excessive clearance between Flywheel Ass'y and Flywheel Holder Ass'y.
- (4) Defective Drive Belt.

14.2.17. Signal to Noise Ratio is deteriorated:

- (1) Record/Playback Head is magnetized.
- (2) Excessive Bias Leakage.
- (3) Record/Playback Head is dirty.
- (4) Defective Record/Playback Head.
- (5) Defective cassette tape.
- (6) Defective DC Power Supply P.C.B. (excessive ripple).
- (7) Defective Input Amplifier (noise is great).
- (8) Defective Output Amplifier (noise is great).
- (9) Incorrect adjustment of hum balance wire.

14.2.18. Channel separation is deteriorated:

- (1) Incorrect tape travel.
- (2) Defective Record/Playback Head.

14.2.19. Tape speed is too fast or slow:

- (1) Defective Motor.
- (2) Defective Motor Governor.
- (3) Pressure Roller is not in contact with Capstan.
- (4) Defective Mute Switch (contacting chassis).
- (5) Defective cassette tape (hard to rotate).

14.2.20. Does not Eject:

- (1) Defective Eject Linkage Arm.
- (2) Defective Stop/Eject Button.
- (3) Eject Linkage Arm is out of place.
- (4) Defective cassette tape.

14.2.21. Level variations:

- (1) Incorrect tape travel.
- (2) Record/Playback Head is dirty.
- (3) Defective Record/Playback Head.
- (4) Record/Playback Head is misaligned.
- (5) Defective cassette tape.
- (6) Incorrect adjustment of Head Base stroke.

14.2.22. Bias does not oscillate:

- (1) No voltage to Bias oscillation circuit.
- (2) Defective Bias oscillation circuit.
- (3) Defective Erase Head (open circuit or short circuit).

14.2.23. No sound from Headphone

- (1) Defective + 9 V Power Supply.
- (2) Defective Headphone Amp.
- (3) Defective Headphone Jack.

14.3. Check method when parts are replaced.

When any part/part ass'y of the Nakamichi 600II is replaced with new one, please check to insure the following:

14.3.1. When Motor is replaced:

- (1) Tape speed.
- (2) Wow/Flutter.
- (3) Drive Belt position (out of place).

14.3.2. When Drive Belt is replaced:

- (1) Drive Belt position (out of place).
- (2) Tape speed.
- (3) Wow/Flutter.

14.3.3. When Record/Playback Head is replaced:

- (1) The inclination of a Record/Playback head.
- (2) Azimuth/Height.
- (3) Tape Travelling.
- (4) Playback output.
- (5) Playback frequency response.
- (6) Overall frequency response.
- (7) Distortion.
- (8) Signal to Noise Ratio.
- (9) Channel separation.

14.3.4. When Erase Head is replaced:

- (1) Tape travelling.
- (2) Azimuth/Height (record/playback head).
- (3) Bias frequency.
- (4) Erasure.
- (5) Overall frequency response.

14.3.5. When Flywheel Ass'y is replaced:

- (1) Clearance between Flywheel and Flywheel Holder.
- (2) Tape travelling.
- (3) Azimuth/Height.
- (4) Tape speed.

14.3.6. When Pressure Roller Ass'y is replaced:

- (1) Tape travelling.
- (2) Azimuth/Height.
- (3) Tape speed.
- (4) Wow/Flutter.
- (5) Pressure Roller timing.

14.3.7. When Tape Counter Ass'y is replaced:

- (1) Tape speed.
- (2) Wow/Flutter.
- (3) Memory rewind operation.
- (4) Counter check (sticky, etc.).
- (5) Auto shut-off operation.

14.3.8. When Reel Hub Ass'y is replaced:

- (1) Torque check (take-up, fastforward and/or rewind).
- (2) Tape speed.
- (3) Wow/Flutter.

14.3.9. When Deck Button Ass'y is replaced:

- (1) Button operation.
- (2) Head base stroke.
- (3) Pause switch operation.
- (4) Record switch operation.
- (5) Mute switch operation.
- (6) Start switch operation.

14.3.10. When Idler Pulley Ass'y is replaced:

- (1) Drive Belt position (out of place).
- (2) Tape speed.
- (3) Wow/Flutter.
- (4) Rewind time.
- (5) Fastforward time.
- (6) Brake Timing.

14.3.11. When Motor Governor is replaced:

- (1) Tape speed.
- (2) Wow/Flutter.

14.3.12. When Level Meter is replaced:

- (1) Meter level.
- (2) Meter check (sticky, etc.).

14.3.13. When Solenoid is replaced:

- (1) Solenoid position.

14.3.14. When Record Link Ass'y is replaced:

- (1) Record Link ass'y adjustment (height).

15. SPECIFICATIONS

Power Source	100, 120, 220/240 V 50/60 Hz
Power Consumption	15 W Max.
Tape Speed	1-7/8 ips. (4.76 cm/sec.) \pm 1%
Wow and Flutter	Less than 0.12% WTD Peak
Frequency Response	40–20,000 Hz \pm 3 dB (SX, EXII Tapes, -20 dB Record Level)
Input	50 k ohms, 50 mV
Output	Line 580 mV (400 Hz, 0 dB, Output Level at Max.) Headphone 45 mW (400 Hz, 0 dB, Output Level at Max.)
Signal to Noise Ratio (Dolby NR In, SX Tape, WTD)	Better than 60 dB 400 Hz, 0 dB WTD rms (Better than 63 dB 400 Hz, 3% THD WTD rms)
Total Harmonic Distortion	Less than 1.5% 400 Hz 0dB (SX, EXII Tapes)
Erasure	Better than 60 dB below saturation level at 1 kHz
Separation	Better than 35 dB, 1 kHz, 0 dB
Crosstalk	Better than 60 dB, 1 kHz, 0 dB
Bias Frequency	105 kHz
Transistors	68
Diodes	31
ICs	2
Dimensions	15.75 (W) x 6.70 (H) x 9.33 (D) inches 400 (W) x 170 (H) x 237 (D) mm
Weight	14.3 lb. (approx.), 6.5 kg.

- Specifications and appearance design are subject to change for further improvement without notice.
- Dolby System under license from Dolby Laboratories.
- The word "DOLBY" and the Double-Symbol are trademarks of Dolby Laboratories.