

modulusTM
OWNER'S MANUAL



Infinity[®]

We at Infinity Systems, Inc. would like to take this opportunity to thank you for choosing the Modulus Loudspeaker System and commend you on your choice. These speakers are the result of years of research, development and experimentation, and represent Infinity's never-ending quest to produce a loudspeaker which combines form and function, science and art, and deliver all of the impact of a live performance. In order to bring out the best from these speakers it is imperative that you read through this manual before connecting and operating them.

Modulus loudspeakers are very special, as are the people who own them. With this in mind we have provided a "Modulus Registration Card" which we invite you to fill out and return to us. This will entitle you to receive periodic updates on the ever-expanding Modulus family as they develop.

CONTENTS:

Unpacking the Loudspeakers	1
Modulus Possibilities	1
Associated Components	2
Positioning the Loudspeakers	2
Bookshelf Placement	3
Installing the Isolation Feet	4
Connecting the Speakers	5
Adjusting the Tweeter Level	6
Care of Enclosures	6
In Case of Trouble	6

UNPACKING THE LOUDSPEAKERS

When unpacking the speakers, care should be taken not to damage the fine finish of the cabinets. Even though the baked polyester resin is durable and scratch resistant, it is, like the beautiful grand piano which it resembles, susceptible to damage if not handled properly. (The removal of fingerprints and other blemishes is covered in the section of this manual, "Care of the Enclosures.") If the speakers have been damaged in transit, contact your dealer or carrier *immediately*.

Packaged along with the Modulus speakers are six (6) black metal isolation feet, six (6) black plastic protective foot covers and one (1) packet of silicone adhesive.

We recommend that you save the packing materials, protected from exposure to moisture, in case of future need.

MODULUS POSSIBILITIES

The Modulus concept is, in a word, versatility. If you have not already done so, we invite you to discuss with your Infinity dealer some of the possible system configurations available for your new sound system, such as:

Mounting the speakers on a pair of the specially-designed Modulus Pedestals, in conjunction with a Modulus 12" Subwoofer (figure 1A);

Mounting the speakers to the walls using the optional Modulus Wall Mount Bracket Kit, in conjunction with a Modulus 12" Subwoofer (figure 1B);

Placing the speakers on a bookshelf or countertop (figure 1C).

Figure 1: Some possible system configurations

A:

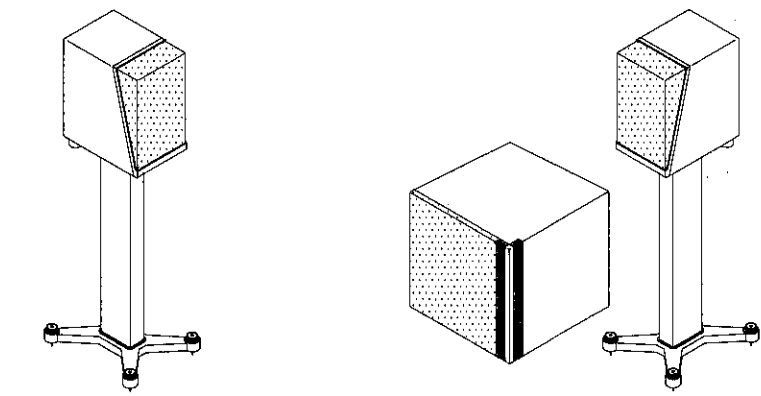

B:

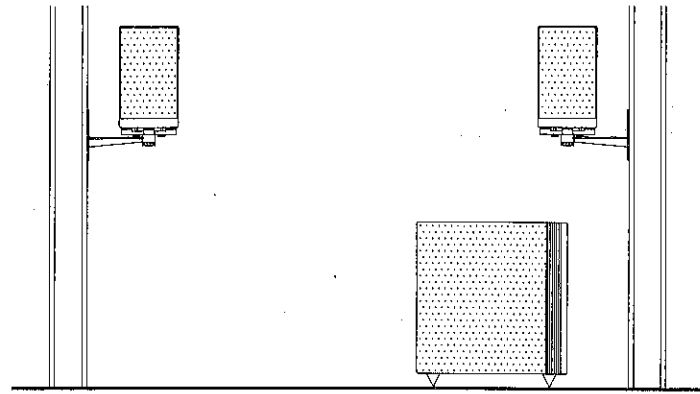

C:

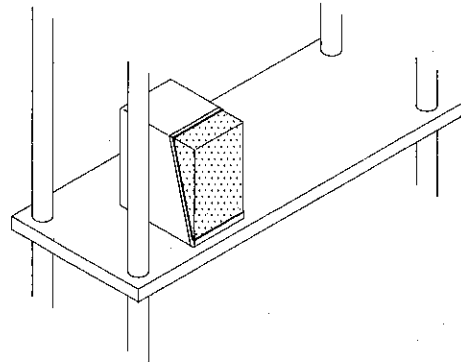

The flexibility of Modulus allows your imagination to be the designer!

ASSOCIATED COMPONENTS

Modulus loudspeakers are very accurate and "revealing" and will faithfully reproduce the audio signal they receive. The cleaner and more accurate the signal, the more pleasing the music. Because of this, the choice of audio components and even connecting cables is extremely important and should be given serious consideration.

Although we cannot recommend which components you should buy, we can offer the following guidelines:

All of the components in your system must be of the highest quality. Remember, the audio chain is only as strong as its weakest link: one poor quality component can degrade the overall sound of your system no matter how good your other components may be. Also, the proper interconnecting and speaker cables are of great importance since skimping here may also keep you from fully realizing the potential of Modulus.

Your power amplifier must be able to deliver its full rated output into a 4 ohm load without clipping. A high-current amplifier, with a strong power supply, will have no trouble driving the Modulus speakers. A weak, low-current amplifier will not allow the speakers to produce clean, well-defined bass (and can damage the tweeters if it is driven past its capabilities).

Modulus loudspeakers require a quality amplifier with an output power rating of 60 to 140 watts-per-channel RMS into 4 ohms.

Your Infinity dealer can respond to any questions you may have concerning component selection as well as make quality suggestions and recommendations.

POSITIONING THE LOUDSPEAKERS

Modulus loudspeakers are designed to perform their best when mounted on the specially designed, acoustically isolated Modulus Pedestals, with plenty of room around them to avoid coloration of the sound from room boundaries. A suggested starting position is offered on the following page: from there, some experimentation will be in order to find the exact placement which yields the most natural sound in your particular listening environment.

For the least coloration of the sound from room boundaries, the speakers must be placed at least 3-4' (1 meter) from the rear and side walls of your listening room: the farther away the better, as long as the speakers are not less than 6-7' (2 meters) apart. The distance from the speakers to the primary listening area should be about 1 1/2-times the distance between the speakers (see figure 2).

Figure 2: Suggested starting position

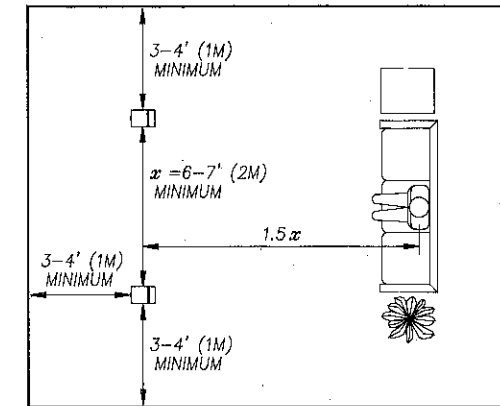

If your listening room is larger than average, and your primary listening position is farther from the speakers than normal, set the speakers further apart and angle them in slightly toward the primary listening area (see figure 3).

Figure 3: Suggested starting position, large rooms

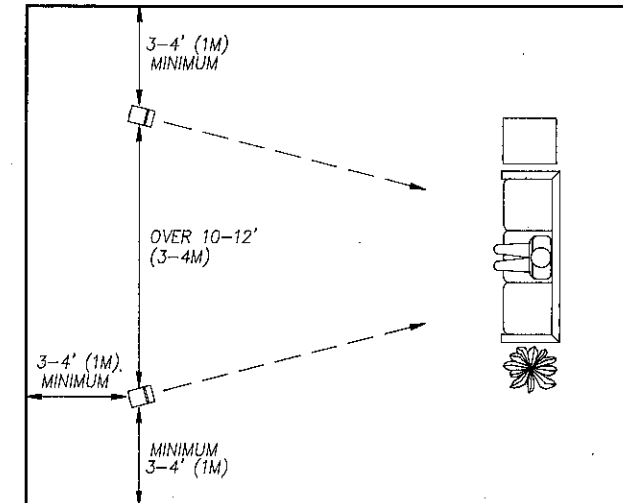

Moving the speakers in relation to the rear and side walls will have an effect on their tonal balance in the bass and lower middle frequencies. Try several different positions, listening to a wide variety of music and making changes in small increments until you find the placement which is most pleasing to you.

BOOKSHELF PLACEMENT

Although the optimum method of installation for the Modulus loudspeakers is on the specially designed Modulus pedestals, you may have chosen to place the speakers on a bookshelf (or countertop, etc.). Place the speakers as far as possible from room boundaries (including the solid vertical risers of some bookcases, for example): preferably, at least 3-4' (1M).

Placing the speakers on the shelf which positions the tweeter closest to the ear level of the primary listening area will provide the best performance when placed on a bookshelf. Do not place the speakers close to the floor or ceiling. Also, placing the speakers towards the front edge of the shelves will help reduce diffraction from the shelves.

Please note that the Modulus loudspeaker is NOT designed to operate placed on its sides: it must be placed vertically at all times.

Figure 4: Bookshelf placement

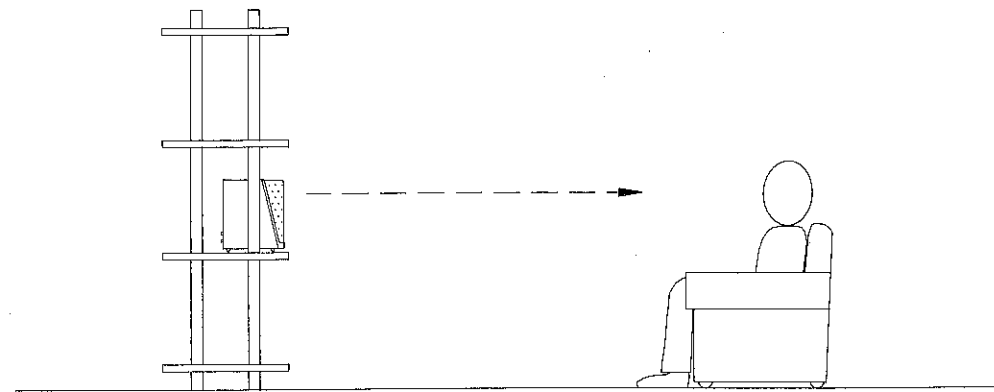

INSTALLING THE ISOLATION FEET

On the underside of the Modulus speaker you will see 5 plastic screws which seal mounting holes in the cabinet. Remove the two screws along the rear edge of the cabinet and the one towards the cabinet's front edge. Screw three of the Modulus isolation feet into these threaded holes (see figure 5).

NOTE: The two remaining holes are used to secure the speakers to the Modulus Pedestal or Wall Mount Bracket and will remain covered if the speaker is not being placed on the pedestals or wall mount brackets.

Figure 5: Installing the feet

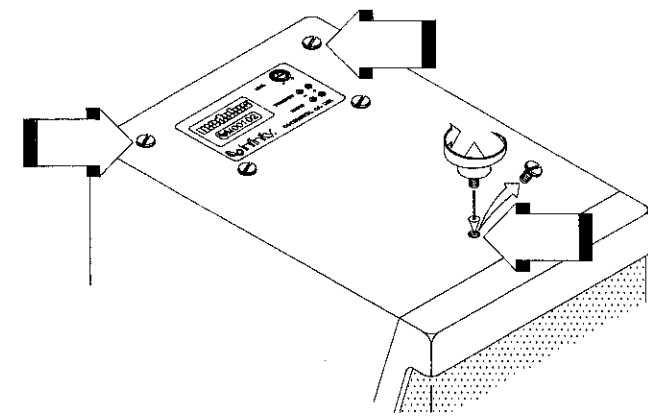

Before setting the speakers onto a bookshelf or countertop, you may choose to use the protective plastic foot covers provided with the speakers to keep the sharp feet from scratching the surface. Supplied with the speakers is a packet of silicone adhesive which you may use to glue the covers to the feet if desired. (Use only a tiny dab of the adhesive on each foot.) Do not use the covers if you are placing the speakers on the Modulus Pedestals, Wall Mount Brackets, or Column Subwoofers. (See figure 6.)

Figure 6: Applying the protective foot covers

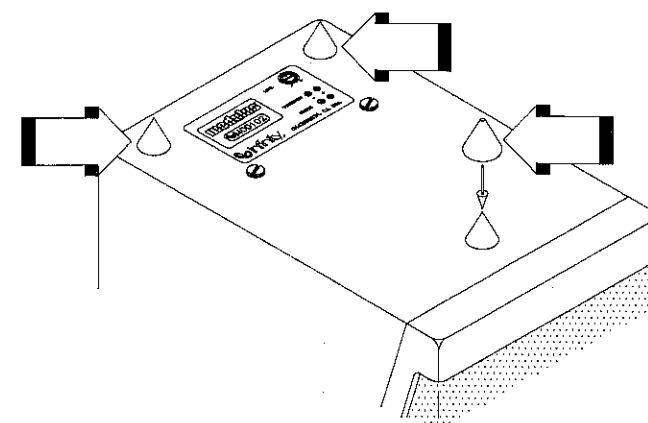

CONNECTING THE SPEAKERS

Turn all components OFF before connecting the speakers.

Your Modulus speakers must be connected using high quality speaker cables of the proper gauge:

Up to 12' (4 meters):	16 gauge minimum
12 to 25' (4 to 8 m):	14 gauge minimum
25 to 50' (8 to 15m):	12 gauge minimum
over 50' (15 meters):	10 gauge minimum

Proper polarity must be observed for the proper performance. If your system is non-inverting, connecting the "+" outputs of your amplifier to the red input terminals and the "-" outputs to the black terminals will keep the system in proper polarity. However, if your audio system inverts its output, then the outputs to the speakers must be reversed (+ to -, - to +) to maintain proper polarity (see figure 7). Most audio components are non-inverting: check your owners's manuals or contact the dealer or manufacturer if in doubt.

Figure 7: Connecting the speakers in proper polarity

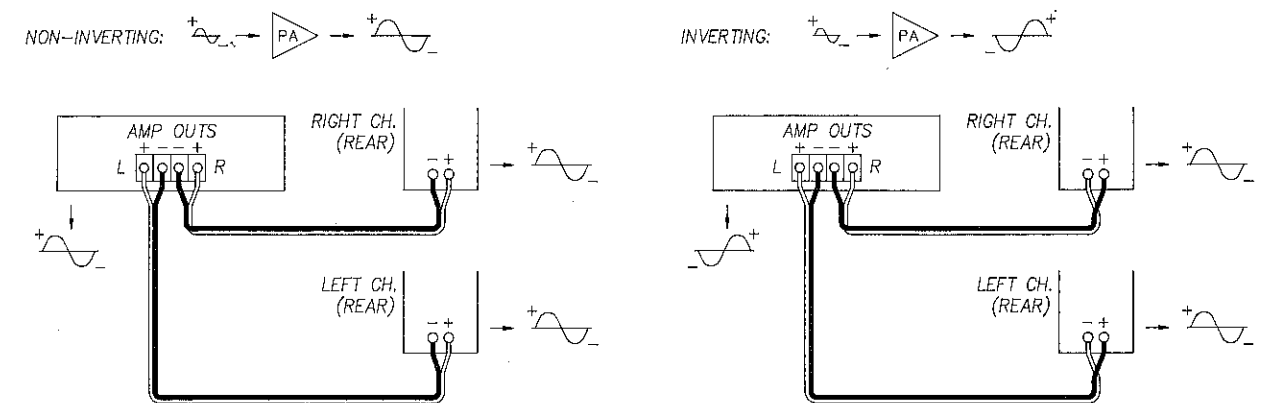

On the back of the Modulus speaker are two pairs of inputs, joined together by gold-plated shorting straps. This configuration offers you the option of using one power amplifier to drive the speaker, or two separate power amplifiers, one driving the woofer and the other driving the tweeter, for optimum power and clarity. (It is believed by many audio experts that this is the best way to achieve optimum performance from high-end speaker systems.) The two pairs of inputs also allow you to use one amplifier to drive the speaker, with two cables connecting it to the speaker (for optimum current flow). Figure 8A shows standard, single-amplifier/single-cable connection, in which the shorting straps are left in place. Figures 8B and 8C show the use of bi-amping and bi-wiring the speaker, in which the shorting straps are removed from the speaker.

Figure 8: Modulus wiring capabilities

A: Using one amplifier and one set of cables

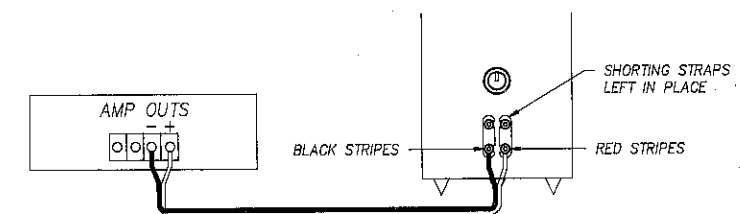

B: Using two amplifiers and two sets of cables (bi-amping)

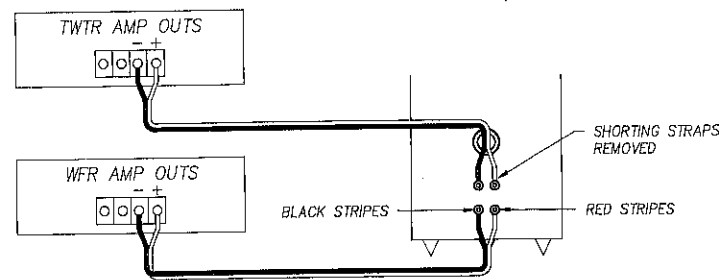

C: Using one amplifier and two sets of cables (bi-wiring)

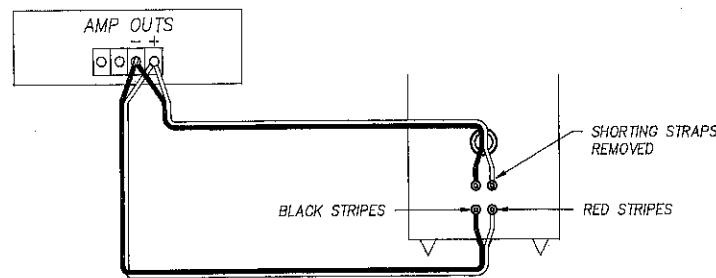

ADJUSTING THE TWEETER LEVEL

On the back of each Modulus speaker, above the input terminals, is the tweeter level control. The output level of the tweeter can be adjusted with this control to match the speaker to your listening room and tailor the overall sound to your liking.

Once your system is connected, listen to a wide variety of your favorite recordings while making small adjustments to the tweeter level. Start with the control at the 12:00 (straight-up) position and adjust it until you find the setting which offers the best balance of highs to mids and lows. Turning the control clockwise will increase the tweeter's output level, while turning it counter-clockwise will reduce its output level. In general, rooms with wide expanses of glass, tile, mirrors and other reflective surfaces will require less output from the tweeters than rooms with heavy drapes, thick carpets and plush furnishings. When the speakers are placed on a bookshelf or near a wall, the tweeter level may need to be increased to compensate for the nearby boundaries.

CARE OF THE ENCLOSURES

The cabinetry of the Modulus loudspeakers is finished with a durable, high-gloss polyester resin scratch resistant piano finish. Treat the finish carefully and keep it clean by dusting it occasionally with a lint-free cotton cloth. Fingerprints and other minor blemishes may be removed with a lint-free cotton cloth slightly dampened with an ammonia-free window cleaner. *Do not use abrasives or chemical cleaners!*

The baffles may be dusted with a lint-free cotton cloth. Fingerprints may be removed by slightly dampening the cloth with plain water, or a mild soap solution.

The grilles may be cleaned by gently vacuuming with a furniture brush attachment.

If the cabinets sustain scratches or other damage, a qualified furniture repair shop should be able to restore them to their original condition.

IN CASE OF TROUBLE

If your Modulus loudspeakers exhibit a change in performance, or quit playing altogether, *immediately* discontinue playing them. Before calling for assistance, follow the instructions to see if you can pinpoint (and possibly correct) the source of the trouble.

Then, if you are unsuccessful in locating or correcting the trouble, contact your Infinity dealer for the name of the service center nearest you, or call Infinity's Customer Service department at (818) 709-9400.

Do not send a loudspeaker or component to a service center or the Infinity Factory without prior authorization.

First, check to see if the fault is in both speakers. If it is, then the problem most likely lies within your audio components or cables. Connect a speaker which is known to operate properly to the speaker cables: if the speaker exhibits the same problem the source of the trouble is elsewhere in your system.

If the fault is in only one speaker, reverse the outputs of your amplifier to the speakers (left-to-right and right-to-left). If the problem moves to the other speaker, the source of the trouble is not in your speakers.

If one of the tweeters seems to be malfunctioning, inspect it carefully for signs of damage: burned, broken or lifted traces on its voice coil, for example. If such damage is found, call the service center. If no damage can be seen, remove the tweeter from the cabinet by extracting the 5/32" socket head screws from around its outer perimeter and switch the tweeter with the one from the other speaker. If the problem follows the tweeter, it is defective. If not, then the problem lies within the speaker's passive crossover network: call for assistance.

If one of the woofers seems to be malfunctioning, remove it from the cabinet and switch it with the one from the other speaker. If the problem follows the woofer, it is defective. If not, then the problem lies within the speaker's passive crossover network: call for assistance.

Infinity strives always to update and improve existing products, as well as create new ones. Therefore, the specifications and construction details in this Infinity publication and others are subject to change without notice.

LIMITED WARRANTY

Who is protected by the warranty?

Your Infinity Warranty protects the original retail purchaser and all subsequent owners, during the stated warranty period, from any failure as a result of an original manufacturing defect so long as: (1) your Infinity product was purchased within the fifty United States, or purchased by military personnel from an authorized military outlet and (2) the original dated bill of sale is presented whenever service is required during the warranty period. This warranty does not apply to products purchased elsewhere; other purchasers should contact their local Infinity distributor for warranty information.

How long is the warranty period?

Product Type	Warranty Period	
	Labor	Parts
Electronic Products	1 year	1 year
Speaker Systems	5 years	5 years

What does the Infinity Warranty cover?

Except as specified below, the Infinity Warranty covers all defects in original materials and workmanship. The following are not covered: Damage caused by accident, misuse, abuse, neglect, product modification; damage occurring during shipment; damage caused by failure to follow instructions in your owner's manual, including failure to perform recommended periodic or routine maintenance; damage resulting from repairs by someone not authorized by Infinity; claims based upon any misrepresentations by the seller; and any Infinity product on which the serial number has been altered, defaced or removed.

Who pays for what?

During the period that both parts and labor are covered by this warranty, Infinity will pay all of the labor and material expenses to repair a warrantable defect; during the period that parts ONLY are covered by this warranty, Infinity will pay for all materials to correct a warranted defect, but you must pay for the labor charges.

How can warranty service be obtained?

In the event that your Infinity product requires service, you should first contact the Infinity dealer from whom the product was purchased or if this is not practical, contact us at Infinity (Attn: Customer Service) at 9409 Owensmouth Avenue, Chatsworth, CA 91311 (818) 709-9400. We may direct you to an authorized service center for Infinity products or ask you to send your unit to us for repair. In either case you will have to present your **original dated bill of sale** to establish warranty coverage. Do not send your product to us without prior authorization.

You are responsible for transporting your product for repair and for payment of all shipping charges. However, Infinity will pay the return shipping charges if the repairs are covered by the warranty. If you experience difficulty in transporting your product, please advise us and we may suggest alternative procedures.

LIMITATION OF IMPLIED WARRANTIES: All implied warranties, including fitness for a particular purpose and merchantability are limited in duration to the length of the warranty period for your product.

LIMITATION OF INCIDENTAL OR CONSEQUENTIAL DAMAGES: Infinity is not responsible for any incidental or consequential damage of any kind. Our liability is limited to the repair or replacement, at our option, of a defective product.

Some states do not allow limitations on how long an implied warranty lasts and/or do not allow the exclusion of incidental or consequential damage, so the above limitations or exclusions may not apply to you.

This warranty gives you specific legal rights and you may also have other rights which vary from state to state.

NOTE: In the event that there is a difference between this warranty and the provisions in your owner's manual, the terms of this warranty will prevail.



We get you back to what it's all about. Music.