

 PIONEER®

SX-850



A High Power AM/FM Stereo Receiver with Super-Quiet Phono Equalizer and Outstanding FM Selectivity/Sensitivity.

How do you know when to trust a stereo receiver to fill your musical needs? Power output by itself is not much help, because unless your listening room is the size of a concert hall, a receiver with far less than concert-hall-sized output will do nicely. The answer, obviously, is to put your trust in the circuitry—the kind that you'll enjoy in the Pioneer SX-850. It delivers a continuous power output of 65 watts* per channel, min. RMS at 8 ohms, from 20 to 20,000 Hertz, with no

more than 0.1% total harmonic distortion. But even more importantly, it has the strength and finesse to handle that power with a healthy respect for musicality. The SX-850 has a super-quiet phono equalizer in a 3-stage direct-coupled design to achieve wide dynamic range and ± 0.2 dBRIAA equalization accuracy. An FET in the Tone Control section, plus a 2-step frequency turnover switch for BASS and another for TREBLE, 2-deck monitor/dubbing, 2-system speaker drive, separable

pre/main and more, mean further control versatility. The superb FM/AM section uses a dual-gate MOS FET and a 4-gang variable capacitor to boost sensitivity and selectivity, a PLL IC in the multiplex to improve stereo separation, and a special Integrated Circuit in the AM for still better reception and less noise. It's the Pioneer SX-850—the one you can trust to keep faith with your musical needs.

*Walnut veneered top and side panels are used in the construction of this cabinet.

*Measured pursuant to the Federal Trade Commission's Trade Regulation Rule on Power Output Claims for Amplifiers.

SX-850

PHONO EQUALIZER OFFERS WIDE DYNAMIC RANGE AND ± 0.2 dB RIAA EQ.



Because the plus/minus split power supply delivers a high voltage (+25V/-16V) at all times to the circuit, the phono equalizer in the Pioneer SX-850 features an extended phono overload of 200mV (1kHz, THD 0.1%) against its input sensitivity of 2.5mV. This assures sufficient dynamic margin to reproduce the very wide dynamic range available in today's records, and to do so with absolute minimal distortion even when large output cartridges are employed. The equalizer circuit has a 3-stage direct-coupled design using a one-stage PNP to achieve high gain amplification. Distortion is kept low by applying sufficient negative feedback. Since the precision elements used permit reproduction within ± 0.2 dB of the RIAA curve, unwanted coloration is avoided and a near-perfect flat frequency response is achieved.

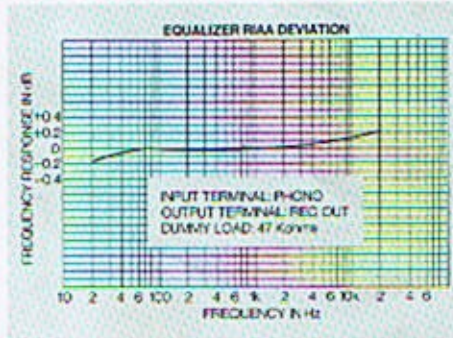
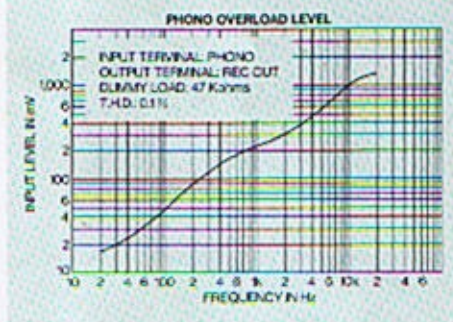

TONE CONTROL FET MINIMIZES NOISE

Pioneer takes maximum advantage of up-to-date circuitry by using an FET (Field Effect Transistor) in the first stage of the flat amplifier in the tone control section. When volume is altered, no additional noise occurs.

TONE CONTROL 2-STEP TURNS FOR BASS AND TREBLE



An independent turnover frequency selector switch is provided for each of the tone controls. BASS turnover is either 200Hz or 400Hz; TREBLE turnover is either 2.5kHz or 5kHz, depending on your selection. A third switch, TONE ON/OFF, is provided to bypass the tone control circuit instantly to provide flat (uncolored) reproduction without changing tone control settings.

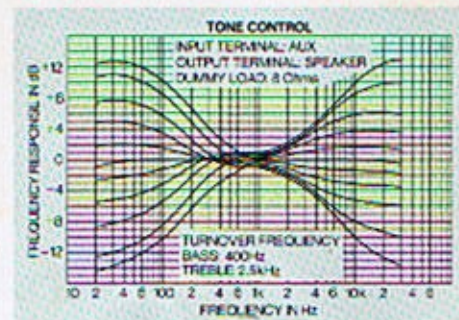
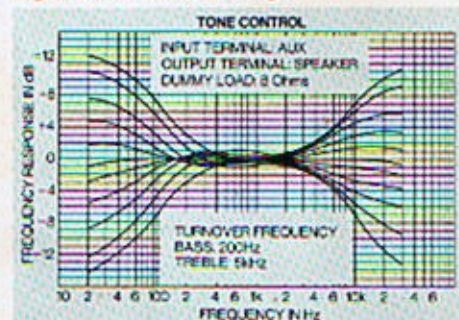

LOW/HIGH FILTERS

The filters in the SX-850 are designed to cut noise in the low and high ranges without harming too much of musical content. For this reason they have sharp cut-off characteristics (6dB/oct.). Cut-off is 30Hz and below for Low and 6kHz and above for High.

POWER AMPLIFIER DELIVERS CLEAN 65 WATTS (RMS) PER CHANNEL WITH LOW DISTORTION AND HIGH S/N

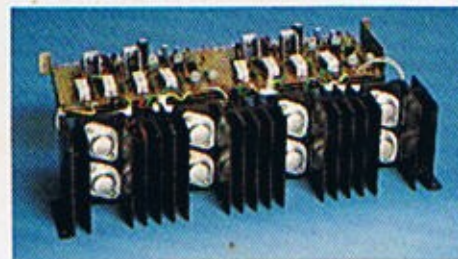

The all-stage direct-coupled OCL circuit in the Pioneer SX-850 delivers a **continuous power output of 65 watts* per channel, min. RMS at 8 ohms, from 20 to 20,000 Hertz, with no more than 0.1% total harmonic distortion.** The circuit has a remarkably good signal-to-noise ratio, and features a first-stage PNP differential amplifier which makes available sufficient negative feedback to lower distortion, suppress voltage fluctuations introduced by outside factors, and increase stability for better musical reproduction. A constant-current differential amplification pre-driver enables the reproduction of massive low-frequency signals by eliminating the time constant in the low range. Power transistors (4 per channel) in the output stage are connected in parallel, dividing the current required by half, to take advantage of increased linearity, improve heat-dissipation efficiency, and provide a large and steady power reserve from the lows through the super-highs. Since the output stage is the single-ended, push-pull type, even-numbered harmonics are eliminated and a wide margin is maintained for low-distortion output.

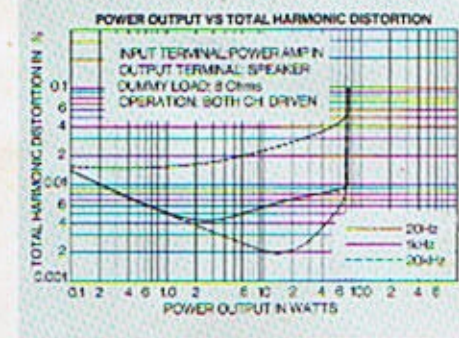

*Measured pursuant to the Federal Trade Comm

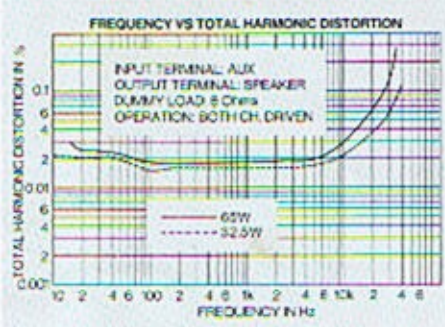
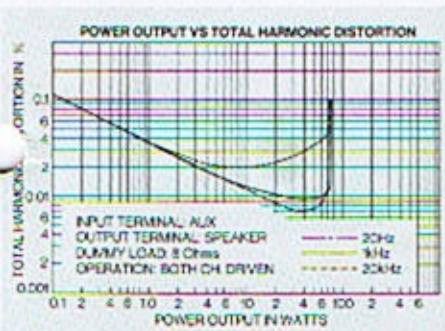

MASSIVE POWER SUPPLY GIVES LOW FREQUENCY SIGNALS REQUIRED HEADROOM

Realistic sound reproduction in the low frequencies — the kind that you not only hear but also feel, is assured with the use of a heavy power supply section: a large transformer using extra-large coil and cores, and two huge power capacitors (15,000µF x 2) provide the headroom this kind of musical reproduction requires.



POWER PROTECTION CIRCUIT PREVENTS DAMAGE

The SX-850 has a power relay type protection circuit (in place of fuses) to prevent the destruction or damage of power output transistors and connected speakers in the event of power-related mishaps. It is self restoring.



Trade Regulation Rule on Power Output Claims for Amplifiers.

HIGH PERFORMANCE FM FRONT END WITH DUAL-GATE MOS FET AND 4-GANG VARIABLE CAPACITOR



Two distinct performance advantages are provided in the carefully designed FM front end of the tuner section in the Pioneer SX-850 — high sensitivity and high selectivity. The first guarantees clean, sensitive reception of weak or distant FM signals, while the second weeds out interference in areas where FM signals may be too strong. The RF amplifier uses a dual-gate MOS FET coupled with a precision 4-gang variable capacitor to achieve both of these prime requisites without compromise. Intermodulation distortion, arising in the non-linear section of a tuner when a "ghost" station appears, is discouraged. The "ghost" is rejected, and the station you want comes through clean and clear.

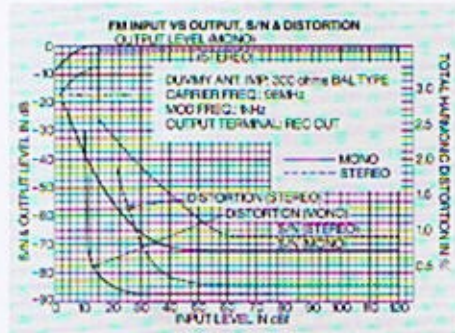

FM IF SECTION WITH THREE 2-ELEMENT CERAMIC FILTERS AND A SPECIAL IC

High selectivity in the IF stage is imperative to prevent alternate channel interference, good capture ratio to reject unwanted FM stations as well as interference on the same frequency as the desired frequency. High selectivity also enhances AM suppression. In the SX-850, three two-element ceramic filters with excellent phase characteristics are employed in the IF stage to ensure superb selectivity, while an advanced LSI (Large Scale Integrated) circuit, comprising more than 200 different elements into an integrated circuit, activates a 5-stage limiter to provide superior AM suppression. Another feature of the FM IF section is a quadrature detector, which covers a wide frequency range and contributes to low distortion and a high S/N ratio.

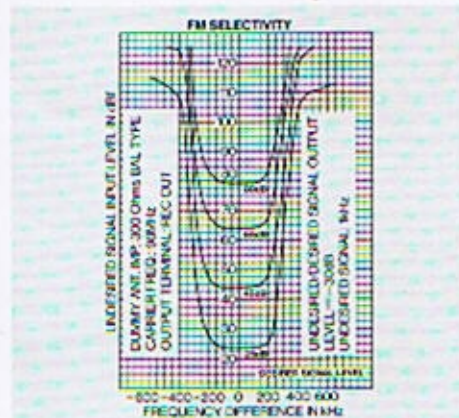

FM STEREO PERFORMANCE UPGRADED WITH PLL (PHASE-LOCKED LOOP) IC, HIGH-GAIN IC AND LOW-PASS FILTER

Conventional multiplex (MPX) circuits in FM tuners are often adversely affected by temperature and humidity changes, and are therefore unstable and unreliable in delivering a properly demodulated (separated) stereo signal. Pioneer ends this difficult technical problem by employing a newly-designed PLL (Phase-Locked Loop) integrated circuit (IC) in the stereo FM section of the SX-850. The PLL is a loop circuit that automatically sees to it that the MPX switching signal produced in the tuner is always in phase with the 19kHz pilot signal transmitted from the stereo FM station. The circuit is impervious to temperature/humidity fluctuations and aging. Pioneer uses two additional innovations in this tuner to improve your FM stereo listening: (1) a new high-gain IC in the PLL itself further contributes to excellent separation characteristics, and (2) a low-pass filter with sharp cut-off leads to a very flat frequency response. The latter also lets you record stereo FM directly with no beat or cross modulation interference and also free from Dolby mis-function.

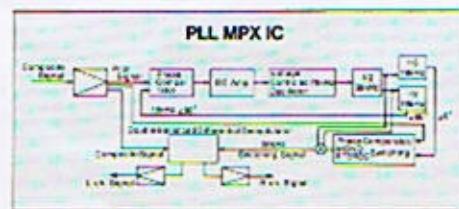
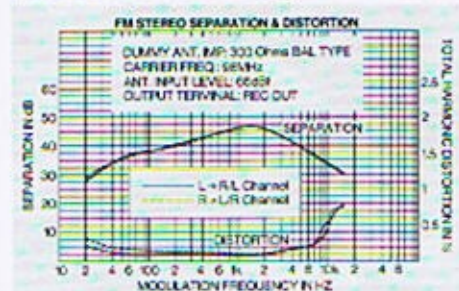

PURE ELECTRONIC FM MUTING

The annoying "static" noise heard between FM stations as you tune, and the "pop" and "thump" sounds heard as you tune past stations, are entirely eliminated by a special 3-transistor, all-electronic muting circuit.

AM RECEPTION IMPROVED WITH SPECIAL INTEGRATED CIRCUIT

Stable power output thanks to excellent AGC (Automatic Gain Control) characteristics regardless of input signal strength is guaranteed in the AM section of the SX-850 with the use of a Pioneer-developed special Integrated Circuit. Improved AM sound is also assured with the use of a first-stage RF amplifier and a 2-gang variable capacitor.

PLEASANT, EFFICIENT DESIGN AND SIMPLE OPERATION

A softly lighted dial scale, calibrated for FM-linear tuning ease in increments of 200kHz, and a simplified switch/control layout on the front panel, are two of the

design elements that contribute not only to good looks but to increased user ease as well. The tuning mechanism employs a large, high-inertia flywheel and a lighted tuning indicator. Twin tuning meters are provided. The front panel is made of durable, easy-to-clean aluminum; side and top panels are finished in walnut grain.

OTHER QUALITY FEATURES



- (1) TAPE-TO-TAPE – Dubbing (copying) a tape from Deck-1 to Deck-2 or vice versa is easy. The switch layout permits the monitoring of either deck or the listening to another source during dubbing.
- (2) INPUTS include PHONO-1, PHONO-2, AUX, ADAPTOR and the two tape input/output circuits.
- (3) A MICROPHONE input circuit is provided, activated (with source selector in

PHONO-2 position) when a mic plug is inserted in the jack provided.

(4) Two sets of stereo SPEAKERS (A and B) may be connected and driven independently or simultaneously (A, B, A+B).



(5) LOUDNESS circuit (switched) compensates lows and highs during low-level listening to achieve flatter response to human ear.

(6) PRE/MAIN terminals are linked by jumper-pins; the SX-850 thus may be interconnected with other amplifiers and/or adaptors.

BLOCK DIAGRAM

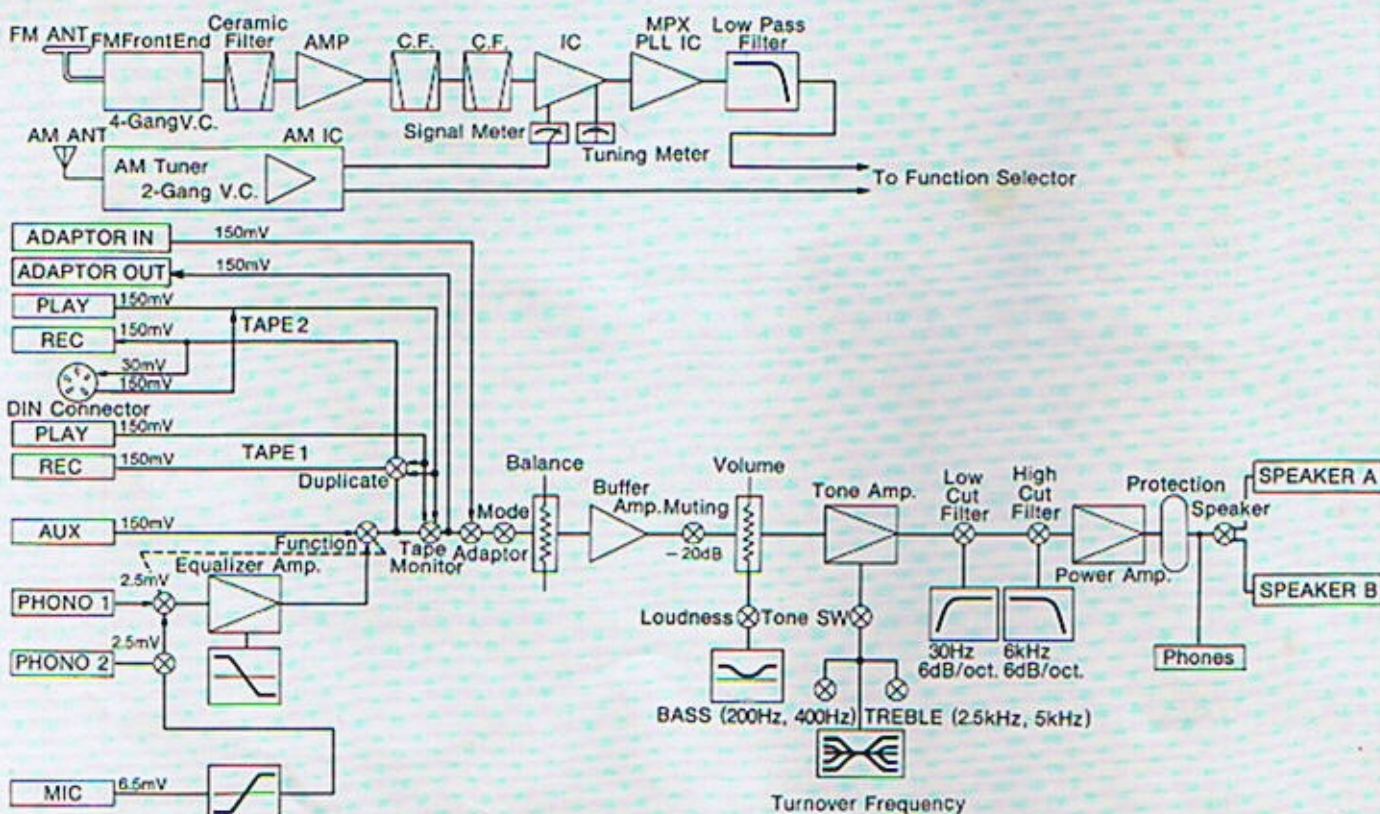

PIONEER

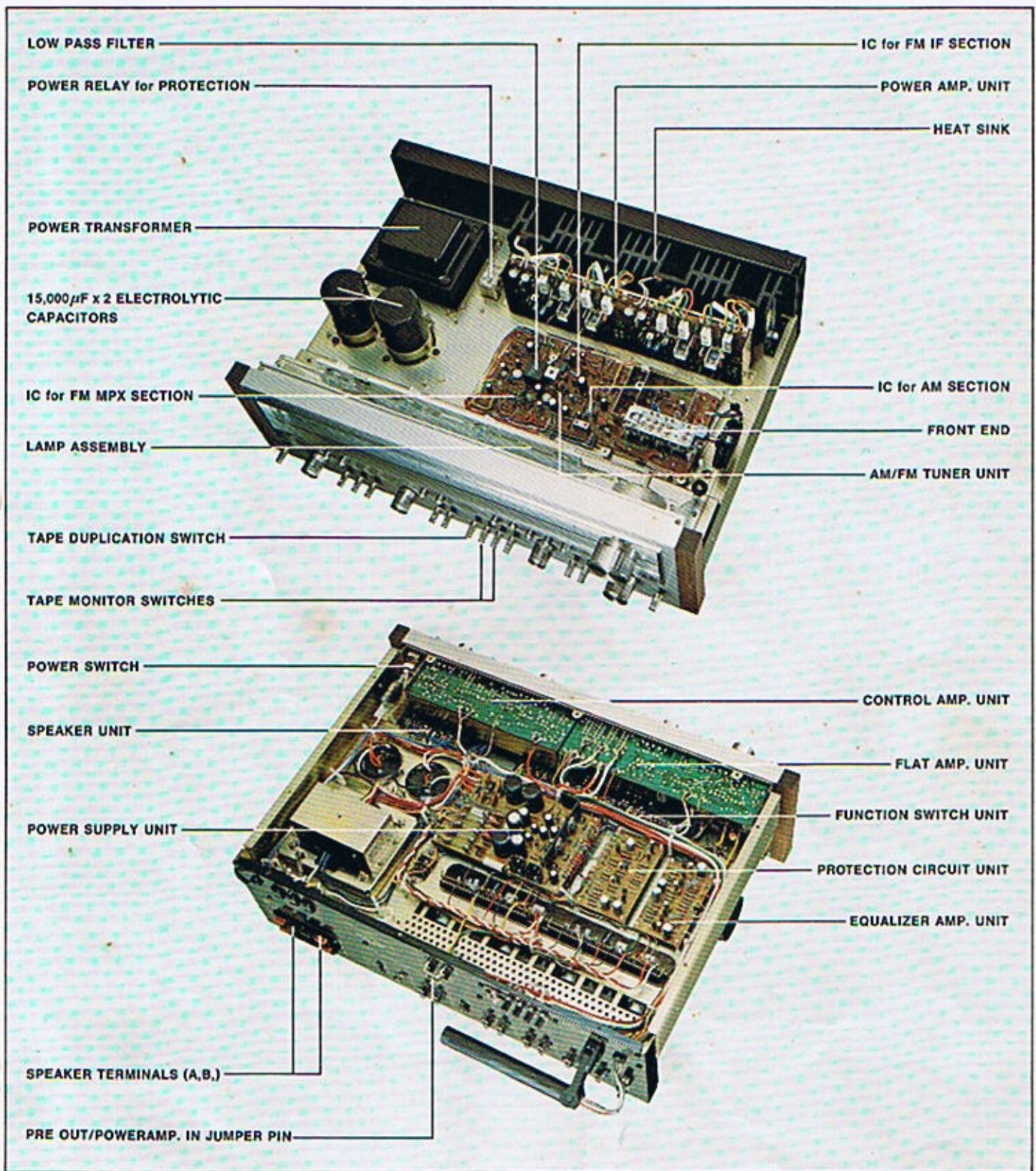
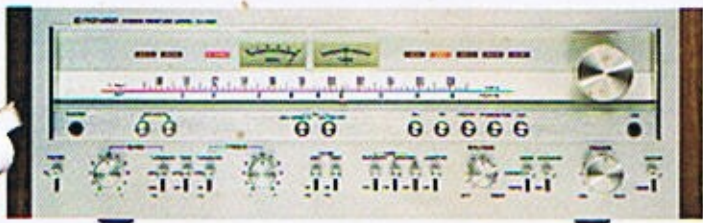

SX-850 SPECIFICATIONS

POWER AMPLIFIER SECTION

Continuous Power Output is 65 watts* per channel, min. RMS at 8 ohms or 85 watts* per channel at 4 ohms from 20 to 20,000 Hertz with no more than 0.1% total harmonic distortion.

Total Harmonic Distortion: (20 to 20,000 Hertz, from AUX)	No more than 0.1% (continuous rated power output) No more than 0.05% (33 watts per channel power output, 8 ohms) No more than 0.05% (1 watt per channel power output, 8 ohms)
Intermodulation Distortion: (50 Hertz; 7,000 Hertz = 4:1, from AUX)	No more than 0.1% (continuous rated power output) No more than 0.05% (33 watts per channel power output, 8 ohms) No more than 0.05% (1 watt per channel power output, 8 ohms)
Frequency Response:	7 to 90,000Hz +0dB, -1dB
Input (Sensitivity/Impedance):	1V/50 Kohms (POWERAMP. IN)
Output Speaker:	A, B, A+B
Headphones:	Low impedance
Damping Factor:	25 (20 to 20,000 Hz, 8 ohms)
Hum and Noise:	100dB (IHF, short-circuited A network)

PREAMPLIFIER SECTION

Input (Sensitivity/Impedance)	
PHONO 1:	2.5mV/50 Kohms
PHONO 2:	2.5mV/50 Kohms
MIC:	6.5mV/50 Kohms
AUX:	150mV/50 Kohms
TAPE PLAY 1:	150mV/50 Kohms
TAPE PLAY 2:	150mV/50 Kohms
TAPE PLAY 2 (DIN connector):	150mV/50 Kohms
PHONO Overload Level (T.H.D. 0.1%)	
PHONO 1:	200mV (1kHz)
PHONO 2:	200mV (1kHz)
Output (Level/Impedance)	
TAPE REC 1:	150mV
TAPE REC 2:	150mV
TAPE REC 2 (DIN connector):	30mV/80 Kohms
PRE OUT:	1V/100 ohms
Total Harmonic Distortion:	No more than 0.05% (20 to 20,000 Hz, 1V output)
Frequency Response	
PHONO (RIAA Equalization):	30 to 15,000Hz, ± 0.2 dB
AUX, TAPE PLAY:	10 to 50,000Hz, +0dB -1dB
Tone Control	
BASS:	± 7 dB/ ± 10 dB (100Hz) Turnover Frequency 200Hz/400Hz
TREBLE:	± 7 dB/ ± 10 dB (10kHz) Turnover Frequency 5kHz/2.5kHz
Filter:	
LOW:	30Hz (6dB/oct.)

HIGH:	6kHz (6dB/oct.)
Loudness Contour:	+6dB (100Hz), +3dB (10kHz) (volume control set at -40dB position)
Hum & Noise (IHF, short-circuited A network, rated power)	
PHONO:	70dB
AUX, TAPE PLAY:	90dB
Muting:	-20dB

FM TUNER SECTION

Usable Sensitivity:	Mono: 10.3dBf (1.8 μ V), Stereo: 22.2dBf (7.1 μ V)
50dB Quieting Sensitivity:	Mono: 17.2dBf (4.0 μ V), Stereo: 38.0dBf (44 μ V)
Signal-to-Noise Ratio (at 65dBf):	Mono: 72dB, Stereo: 67dB
Distortion (at 65dBf)	
100Hz:	Mono: 0.15%, Stereo: 0.3%
1kHz:	Mono: 0.15%, Stereo: 0.3%
6kHz:	Mono: 0.4%, Stereo: 0.4%
Frequency Response:	30 to 15,000Hz +0.2dB, -2.0dB
Capture Ratio:	1.0dB
Alternate Channel Selectivity:	80dB
Spurious Response Ratio:	100dB
Image Response Ratio:	85dB
IF Response Ratio:	100dB
AM Suppression Ratio:	55dB
Muting Threshold:	14.0dBf (2.8 μ V)
Stereo Separation:	40dB (1kHz), 30dB (30 to 15,000Hz)
Subcarrier Product Ratio:	62dB
SCA Rejection Ratio:	62dB
Antenna Input:	300 ohms balanced, 75 ohms unbalanced

AM TUNER SECTION

Sensitivity:	300 μ V/m (IHF, ferrite antenna), 15 μ V (IHF, ext. antenna)
Selectivity:	35dB
Signal-to-Noise Ratio:	50dB
Image Response Ratio:	40dB
IF Response Ratio:	65dB
Antenna:	Built-in ferrite loopstick antenna

SEMICONDUCTORS

FETs:	3
ICs:	3
Transistors:	56
Diodes:	36

MISCELLANEOUS

Power Requirements:	For U.S.A. and Canada: 120V 60Hz only, For other countries: 220/240V (switchable) 50Hz or 110/120/220/240V (switchable) 50-60Hz
Power Consumption:	180 watts (UL), 400 VA (CSA), 500 watts (Max.)
Dimensions:	Without package: 20-23/32(W) x 6-13/16(H) x 16-3/16(D) inches 526.8(W) x 173(H) x 411.5(D)mm Without package: 42 lb. 2 oz./19.1kg
Weight:	

NOTE: Specifications and design subject to possible modification without notice.

*Measured pursuant to the Federal Trade Commission's Trade Regulation Rule on Power Output Claims for Amplifiers.



PIONEER ELECTRONIC CORPORATION / 4-1, Meguro 1-chome, Meguro-ku, Tokyo 153, Japan
U.S. PIONEER ELECTRONICS CORPORATION / 75 Oxford Drive, Moonachie, New Jersey 07074, U.S.A.
PIONEER ELECTRONIC (EUROPE) NV / Luthegen Haven 9, 2030 Antwerp, Belgium
PIONEER ELECTRONICS AUSTRALIA PTY. LTD. / 178-184 Bouncery Road, Braeside, Victoria 3195, Australia