

# Operating Instructions

# REVERBERATION AMPLIFIER SR-60

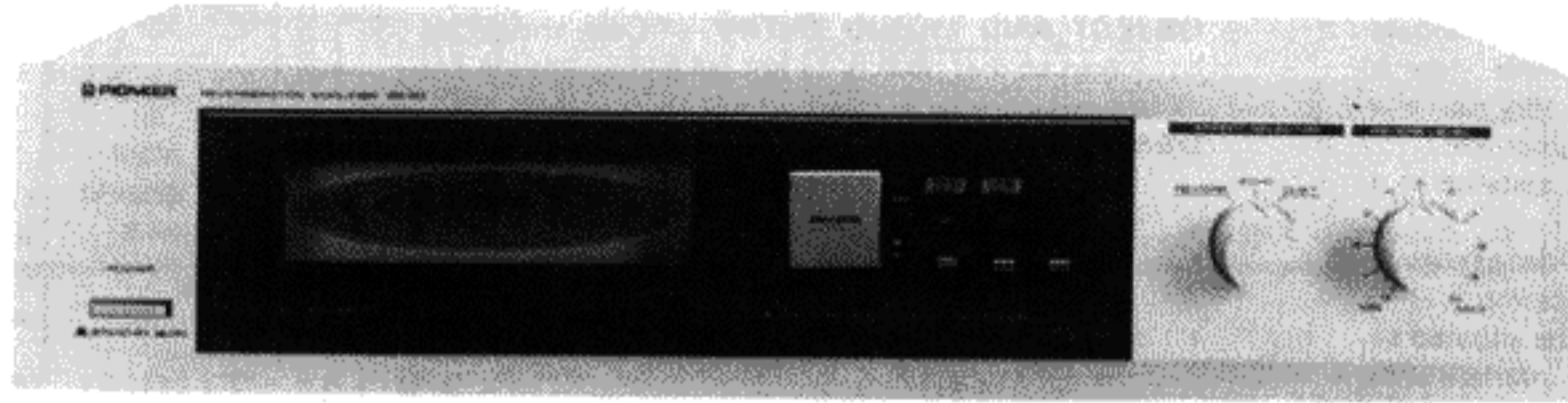

Thank you for buying this Pioneer product. Please read through these operating instructions and then you will know how to operate your model properly. After you have finished reading the instructions, put them away in a safe place for future reference.

These operating instructions are based on the model KU, and they can be used for the KC, HEM, HB, YP, S, S/G models. The differences between the models are given below.

#### HEM model:

For Europe ('HEM' stamped on packing case): power line voltage is a.c. 220 volts ~.

#### HB model:

For U.K. ('HB' stamped on packing case): power line voltage is a.c. 240 volts ~.

#### YP model:

For Australia ('YP' stamped on packing case): power line voltage is a.c. 240 volts ~.

#### KU and KC models:

For U.S.A. and Canada ('KU' or 'KC' stamped on packing case): power line voltage is AC120 volts.

#### S and S/G models:

For destinations excluding above (S or S/G stamped on packing case), A 4 point (AC110/120/220/240 volts) voltage selector switch is provided.

[For KC model]

**CAUTION:** TO PREVENT ELECTRIC SHOCK DO NOT USE THIS (POLARIZED) PLUG WITH AN EXTENSION CORD, RECEPTACLE OR OTHER OUTLET UNLESS THE BLADES CAN BE FULLY INSERTED TO PREVENT BLADE EXPOSURE.

**ATTENTION:** POUR PREVENIR LES CHOCS ELECTRIQUES NE PAS UTILISER CETTE FICHE POLARISEE AVEC UN PROLONGATEUR UNE PRISE DE COURANT OU UNE AUTRE SORTIE DE COURANT, SAUF SI LES LAMES PEUVENT ETRE INSEREES A FOND SANS EN LAISSER AUCUNE PARTIE A DECOUVERT.

## LINE VOLTAGE SELECTOR SWITCH

Only S and S/G models are provided with this switch but KU, KC and other models (HEM, HB, YP) are not provided with this switch. You will find the line voltage selector switch on rear panel. This switch has positions for 110V, 120V, 220V and 240V power sources. Before your model is shipped from the factory, the switch is set to the power requirements of the destination; nevertheless, you should check that it is set properly before plugging the power cord into the AC outlet. If the voltage is not properly set or if you move to an area where the voltage requirements differ, adjust the selector switch as follows. Before adjusting, disconnect the power cord.

1. Provide yourself with a medium size screwdriver.
2. Insert the screwdriver into the arrow on the voltage selector and adjust so that the tip of the arrow points to the voltage value of your area.

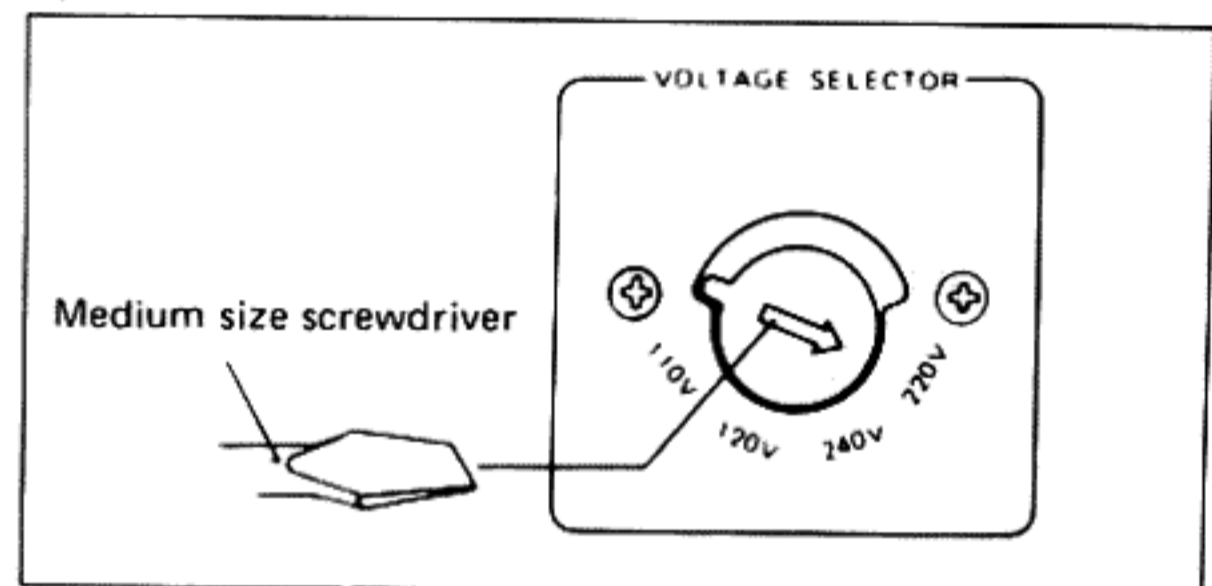

## IMPORTANT NOTICE

[For KU and KC models]

The serial number for this equipment is located on the rear panel. Please write this serial number on your enclosed warranty card and keep in a secure area. This is for your security.

**WARNING: TO PREVENT FIRE OR SHOCK HAZARD, DO NOT EXPOSE THIS APPLIANCE TO RAIN OR MOISTURE.**

## CONTENTS

REAR PANEL FACILITIES . . . . .	3	USING A TAPE DECK . . . . .	7
CONNECTIONS . . . . .	4	EFFECTIVE OPERATION . . . . .	8
FRONT PANEL FACILITIES . . . . .	5	BLOCK DIAGRAM . . . . .	12
OPERATION . . . . .	6	SPECIFICATIONS . . . . .	12

# SAFETY INSTRUCTIONS [FOR KU MODEL]

**READ INSTRUCTIONS** — All the safety and operating instructions should be read before the appliance is operated.

**RETAIN INSTRUCTIONS** — The operating instructions should be retained for future reference.

**HEED WARNING** — All warnings on the appliance and in the operating instructions should be adhered to.

**FOLLOW INSTRUCTIONS** — All operating and use instructions should be followed.

**WATER AND MOISTURE** — The appliance should not be used near water — for example, near a bathtub, washbowl, kitchen sink, laundry tub, in a wet basement, or near a swimming pool, etc.

**LOCATION** — The appliance should be installed in a stable location.

**WALL OR CEILING MOUNTING** — The appliance should not be mounted to a wall or ceiling.

**VENTILATION** — The appliance should be situated so that its location or position does not interfere with its proper ventilation. For example, the appliance should not be situated on a bed, sofa, rug, or similar surface that may block the ventilation openings; or, placed in a built-in installation, such as a bookcase or cabinet that may impede the flow of air through the ventilation openings.

**HEAT** — The appliance should be situated away from heat sources such as radiators, heat registers, stoves, or other appliances (including amplifiers) that produce heat.

**POWER SOURCES** — The appliance should be connected to a power supply only of the type described in the operating instructions or as marked on the appliance.

**POWER-CORD PROTECTION** — Power-supply cords should be routed so that they are not likely to be walked on or pinched by items placed upon or against them, paying particular attention to cords at plugs, convenience receptacles, and the point where they exit from the appliance.

**CLEANING** — The appliance should be cleaned only with a polishing cloth or a soft dry cloth. Never clean with furniture wax, benzene, insecticides or other volatile liquids since they may corrode the cabinet.

**POWER LINES** — An outdoor antenna should be located away from power lines.

**NONUSE PERIODS** — The power cord of the appliance should be unplugged from the outlet when left unused for a long period of time.

**OBJECT AND LIQUID ENTRY** — Care should be taken so that objects do not fall and liquids are not spilled into the enclosure through openings.

**DAMAGE REQUIRING SERVICE** — The appliance should be serviced by Pioneer authorized service center or qualified service personnel when:

- The power-supply cord or the plug has been damaged; or
- Objects have fallen, or liquid has been spilled into the appliance; or
- The appliance has been exposed to rain, or
- The appliance does not appear to operate normally or exhibits a marked change in performance; or
- The appliance has been dropped; or the enclosure damaged.

**SERVICING** — The user should not attempt to service the appliance beyond that described in the operating instructions. For all other servicing, contact the nearest Pioneer authorized service center.

**OUTDOOR ANTENNA GROUNDING** — If an outside antenna is connected to the antenna terminal, be sure the antenna system is grounded so as to provide some protection against voltage surges and built up static charges.

In the U.S.A. section 810 of the National Electrical Code, ANSI/NEPA No. 70-1981, provides information with respect to proper grounding of the mast and supporting structure, grounding of the lead-in wire to an antenna discharge unit, size of grounding conductors, location of antenna-discharge unit, connection to grounding electrodes, and requirements for the grounding electrode. See Fig. A.

## EXAMPLE OF ANTENNA GROUNDING AS PER NATIONAL ELECTRICAL CODE INSTRUCTIONS

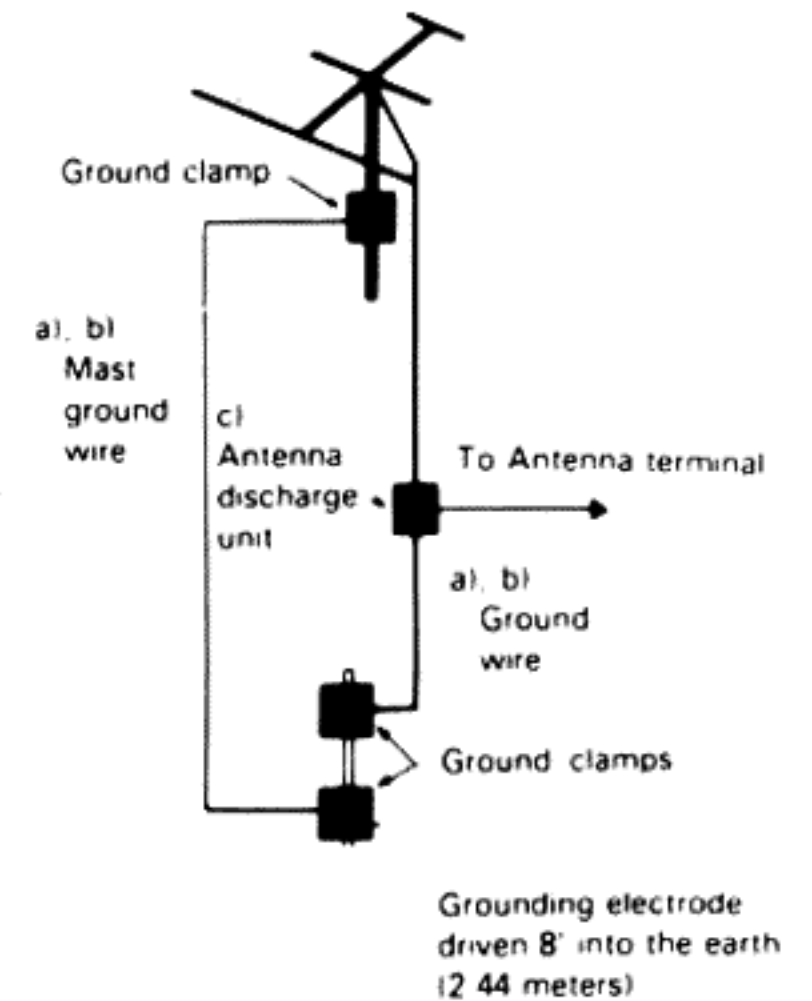

Fig. A

- Use No. 10 AWG (5.3 mm<sup>2</sup>) copper or No. 8 AWG (8.4 mm<sup>2</sup>) aluminum or No. 17 AWG (1.0 mm<sup>2</sup>) copper-clad steel or bronze wire, or larger as ground wires for both mast and lead-in.
- Secure lead-in wire from antenna to antenna discharge unit and mast ground wire to house with stand-off insulators, spaced from 4 feet (1.22 meters) to 6 feet (1.83 meters) apart.
- Mount antenna discharge unit as closely as possible to where lead-in enters house.

## IMPORTANT [FOR KU MODEL]



The lightning flash with arrowhead, within an equilateral triangle, is intended to alert the user of the presence of uninsulated "dangerous voltage" within the product's enclosure that may be of sufficient magnitude to constitute a risk of electric shock to persons.

**CAUTION**  
**RISK OF ELECTRIC SHOCK**  
**DO NOT OPEN**

**CAUTION:**  
**TO PREVENT THE RISK OF ELECTRIC SHOCK, DO NOT REMOVE COVER (OR BACK). NO USER-SERVICEABLE PARTS INSIDE. REFER SERVICING TO QUALIFIED SERVICE PERSONNEL.**



The exclamation point within an equilateral triangle is intended to alert the user of the presence of important operating and maintenance (servicing) instructions in the literature accompanying the appliance.

## IMPORTANT 2

If the apparatus is fitted with AC main power outlet(s), see REAR PANEL FACILITIES for convenient connection of additional Hi-Fi component(s). Make all connections to the AC outlet(s) and the signal terminals first. Connect the plug to the wall socket last, make sure that the power switch is off. Disconnect the wall plug when the equipment is not in regular use, e.g. when on vacation.

### FOR USE IN THE UNITED KINGDOM AND AUSTRALIA

**CAUTION 240 V:** Mains supply voltage is factory adjusted at 240 V.

### FOR USE IN THE UNITED KINGDOM

**WARNING:** This plug must only be connected to electronic apparatus equipped with suitable sockets. Otherwise cut off and dispose of the plug, and fit an appropriate one in accordance with the instruction below.

The wires in this mains lead are coloured in accordance with the following code:

Blue: Neutral  
Brown: Live

As the colours of the wires in the mains lead of this apparatus may not correspond with the coloured marking identifying the terminals in your plug proceed as follows:

The wire which is coloured blue must be connected to the terminal which is marked with the letter N or coloured black.

The wire which is coloured brown must be connected to the terminal which is marked with the letter L or coloured red.

# CONNECTIONS

## CONNECTION DIAGRAM

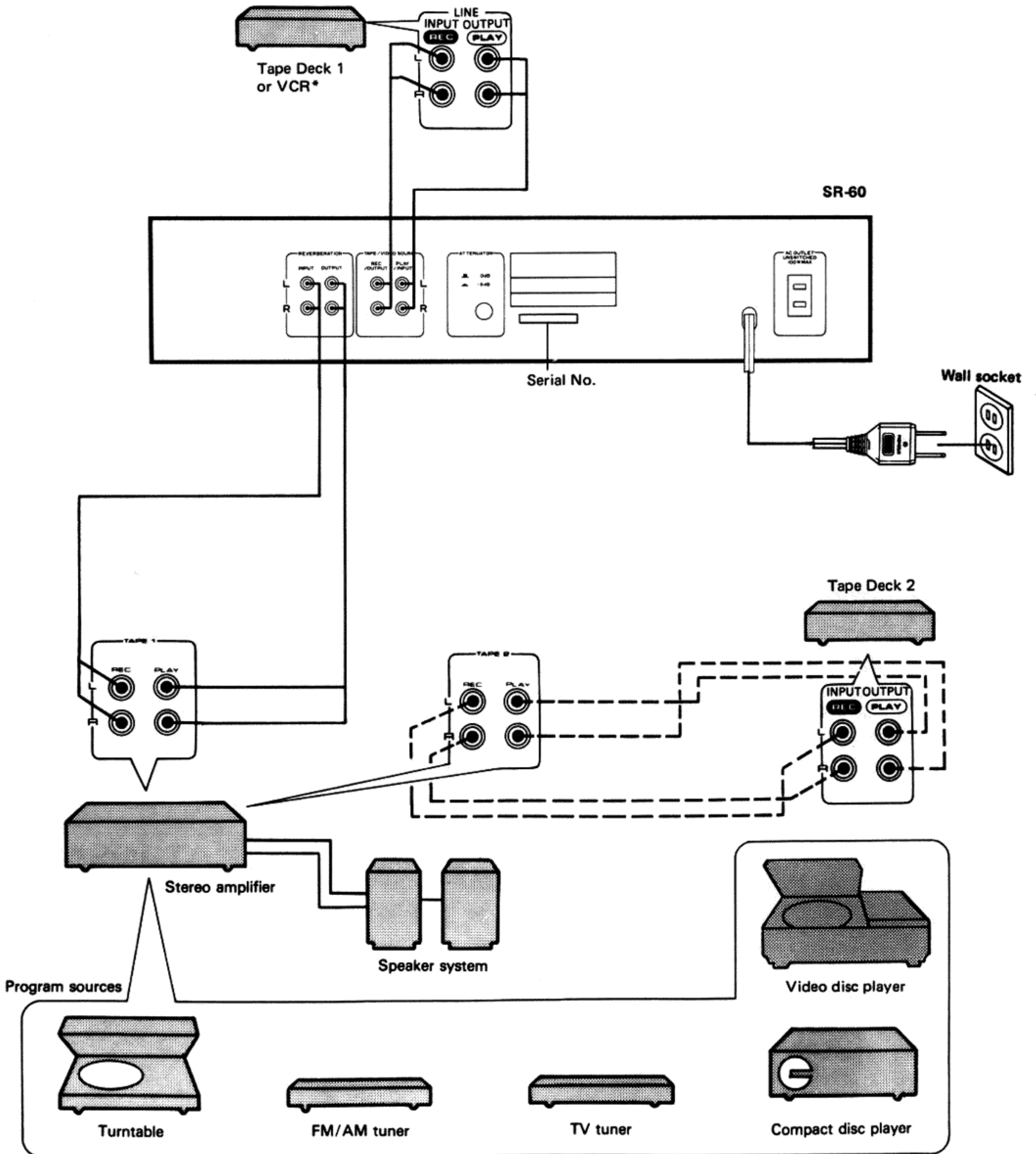

\* If the VCR is not applicable for stereo, use a "Stereo-monaural" converting cord available on the market.

# FRONT PANEL FACILITIES

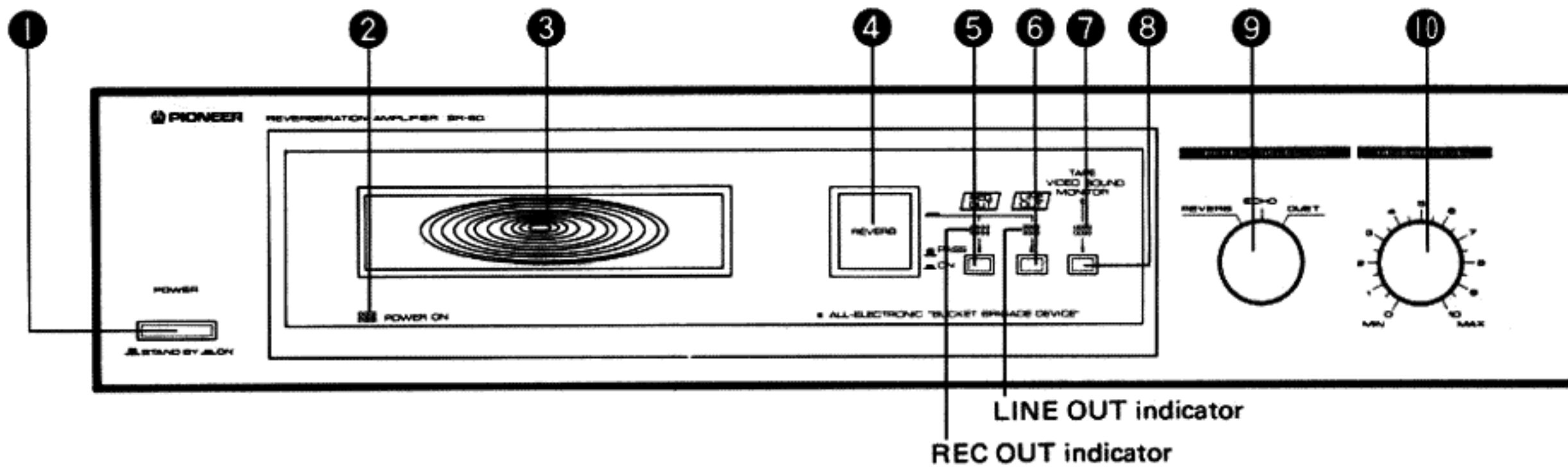

## 1 POWER SWITCH

When this switch is set to the ON position, power is supplied to the unit's main circuits and the indicator lights. The unit's power switch is geared to selecting the transformer's secondary and so even at the STANDBY position, the unit's circuitry will work as long as the power cord is connected to the power outlet. Disconnect the power cord from the power outlet when you do not plan to use the unit for a long period of time.

## 2 POWER INDICATOR

This comes on as soon as the SR-60's power switch is set to ON to indicate that power is being supplied.

## 3 REVERBERATION EFFECT INDICATOR

This graphically displays the reverberation effect. When the reverberation effect is increased (the REVERB LEVEL control is rotated clockwise) the winking intervals of the light are lengthened. Conversely, when this time is reduced (the reverb level control is rotated counterclockwise), these intervals are cut short. The lighting area also increases in proportion to the size of the reverberation components. This area is increased as the reverb level control is rotated clockwise. The reverb level control is set to the preferred position as you check out the reverberation, but if the reverberation indicator's circle of light remains on the display, it means that the reverberation components are excessive (too much echo). Use this as a base for adjustments.

## 4 REVERBERATION SWITCH

Depress this switch to produce a reverberation effect with the signals fed from the REVERBERATION INPUT jacks. The reverberation effect indicator will come on, and signals featuring a reverberation effect only will be fed out from the model SR-60's OUTPUT jacks.

## 5 RECORDING (REC) OUT SWITCH

Depress this switch when recording a program source whose signals feature a reverberation effect onto a tape in a deck connected to the model SR-60's TAPE/VIDEO SOUND jacks. This will allow signals with the reverberating sound to be made available from the SR-60's the TAPE REC/OUTPUT jacks.

## 6 LINE OUT SWITCH

Depress this switch to produce a reverberation effect with the signals fed from the REVERBERATION INPUT jacks or TAPE/VIDEO SOUND MONITOR PLAY jacks.

### NOTE:

The REC OUT switch and LINE OUT switch are coupled. When you depress one switch, make sure that another is released. Do not depress more than one switch at a time.

## 7 TAPE/VIDEO SOUND MONITOR INDICATOR

This comes on when the tape monitor switch is depressed.

## 8 TAPE/VIDEO SOUND MONITOR SWITCH

Depress this switch to monitor the sound on the tape as it is being recorded or when playing back a tape using a tape deck connected to the SR-60's TAPE/VIDEO SOUND jacks (the tape monitor indicator comes on).

## 9 EFFECT SELECTOR

Use these to select the type of reverb effect.

REVERB: For normal reverb effect.

ECHO: For an echo effect even though only one person is singing. This is particularly effective with an electric guitar.

DUET: For a duet effect even though only one person is singing.

Try out the selector and find the best combinations that suit your particular purpose.

## 10 REVERB LEVEL CONTROL

This is used to adjust the depth of the reverberation. When it is set to the '0' (MIN) position, only the original sound will be heard. The reverberation component increases as this control is rotated clockwise. Listen to the sound as it reverberates and adjust this control to the optimum position.

# OPERATION

---

## PRIOR TO SWITCHING POWER ON

Set the controls and switches to the following positions before operating the model SR-60.

1. Select the EFFECT selector.
2. Set the REVERB LEVEL control to the '0' (MIN) position.
3. Set the REVERBERATION switch to the PASS position.
4. Set the tape monitor switch to OFF (released).
5. Set the tape monitor switch (which is related to the TAPE jacks connecting the SR-60) on the stereo amplifier to ON.

### NOTE:

*Even when the SR-60's power switch is at stand-by, the INPUT signal will bypass the reverberation circuit and it will be fed out to the OUTPUT jacks and TAPE REC jacks when the reverberation switch is depressed (PASS position).*

## Operation procedure

1. Play the program source on the stereo amplifier, and listen to the sound without adding the reverberation effect.
2. Set the REVERBERATION switch to ON.
3. Select the EFFECT selector. Set this control to the optimum position.
4. Rotate the REVERB LEVEL control. Set this control to the optimum position.

The level fluctuations of the reverberated sound will make the reverberation indicator's light ring weak and strong. Rotate the reverb level control and adjust so that the light ring fluctuates widely between strong light and weak light. Remember that when the light ring of the reverberation indicator comes on strongly, the reverberation effect is excessive.

## USING THE ECHO/REVERB EFFECT

When you sing in a bathroom or hall, you can sound almost professional – unlike the way you normally sound. This is due to the echo effect. The depth of the echo can be adjusted as desired with this unit. Three types of echo effect can be selected.

### **Making the most of the echo reverb/effect with a background music tape:**

The important point to remember is to keep the sound volume of the background music tape to a level slightly lower than the vocals. This will result in wellbalanced mixing and full use of the echo effect.

## ECHO TYPES AND EFFECTS

### **REVERB effect**

Set this selector to add a normal echo to all the channels or to give added depth to the sound.

### **ECHO effect**

Set this selector to provide a chorus atmosphere even though only one person is singing. It is really effective for guitars.

### **DUET effect**

Set this selector to provide a duet effect where it appears that two people are singing instead of one.

# USING A TAPE DECK

## WHEN PRODUCING A REVERBERATION EFFECT IN THE REPRODUCED SIGNAL ONLY AND RECORDING THE ORIGINAL SOUND (WITHOUT THE REVERBERATION EFFECT) ON A TAPE DECK:

1. Depress the reverberation switch (make sure the REC OUT switch is released).
2. Set the tape deck which you have connected to the model SR-60's TAPE jacks to the recording mode.
3. The original sound is now available at the TAPE REC jacks. When monitoring the recording, depress the tape/video sound monitor switch (the tape video sound monitor indicator comes on).

## WHEN RECORDING A SIGNAL WITH THE REVERBERATION EFFECT

1. Depress the reverberation switch (make sure the LINE OUT switch is released).
2. Set the tape deck which you have connected to the model SR-60's TAPE jacks to the recording mode.
3. When monitoring the recording, depress the tape/video sound monitor switch (the tape/video sound monitor indicator comes on).

## WHEN PRODUCING A REVERBERATION EFFECT IN THE PLAYBACK SIGNALS OF THE TAPE DECK.

1. Depress the tape/video sound monitor switch (the tape/video sound monitor indicator comes on).
2. Set the tape deck which you have connected to the model SR-60's TAPE jacks to the playback mode.
3. Depress the reverberation switch (make sure the REC OUT switch is released). If you want to reproduce the original sound (without the reverberation effect) when the SR-60 is used between a preamplifier and a power amplifier, release the reverberation switch (PASS) and the tape/video sound monitor switch. There is no need to set the power switch to ON.

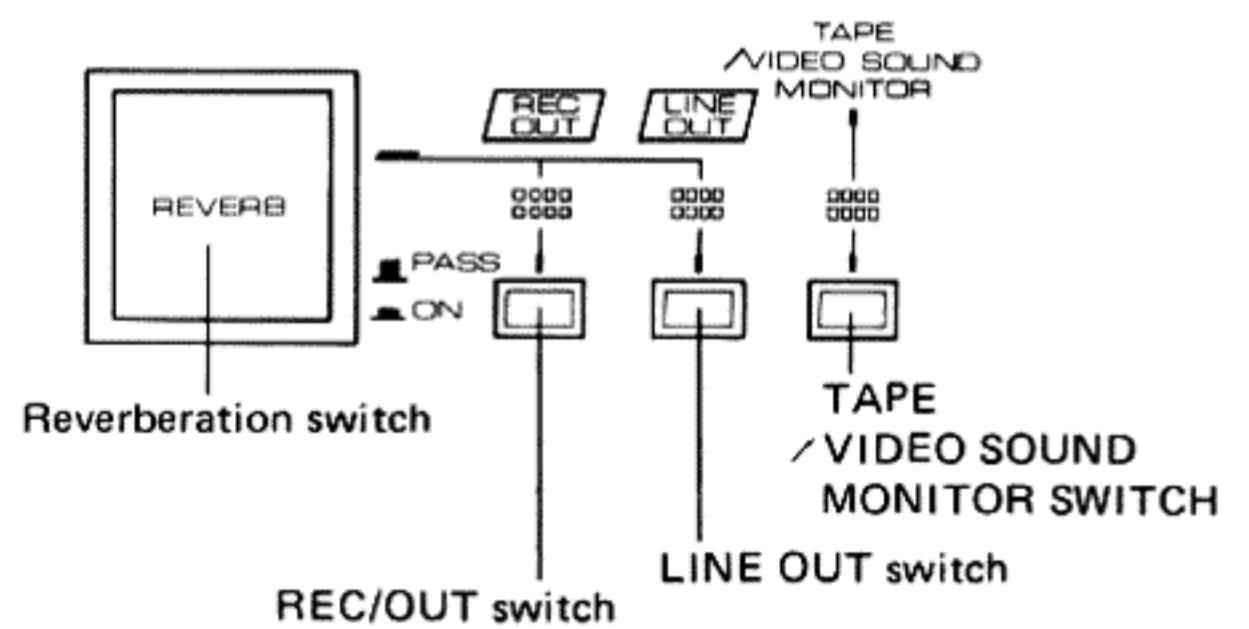

Relationship between signals and combinations of the REVERB switch and tape/video sound monitor switch

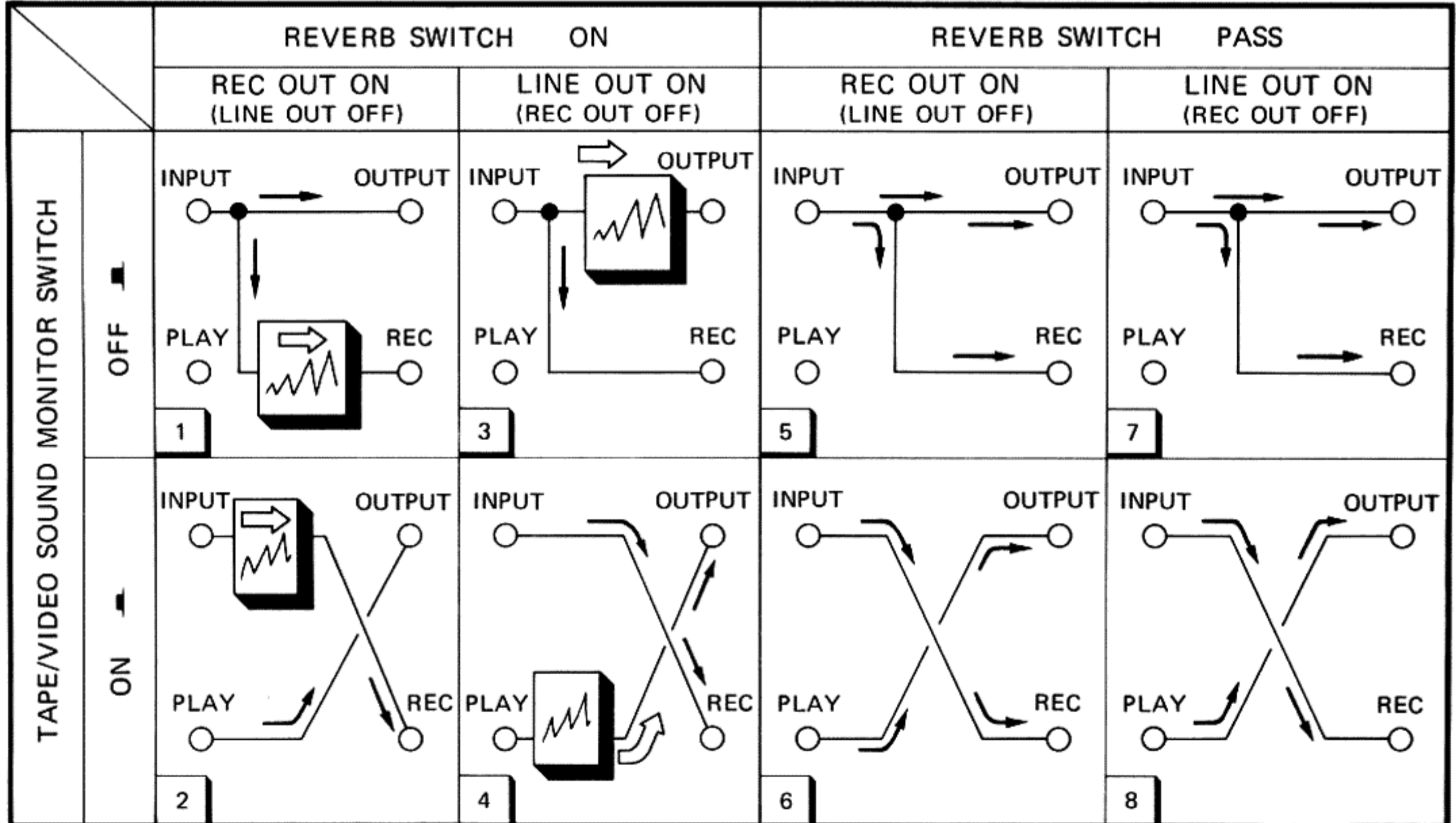

→ : Non-Processed signal (original signal)    ⇨ : Processed signal    *W* : Reverberation

# EFFECTIVE OPERATION

1. When the SR-60 and SG-60 are used at the same time.

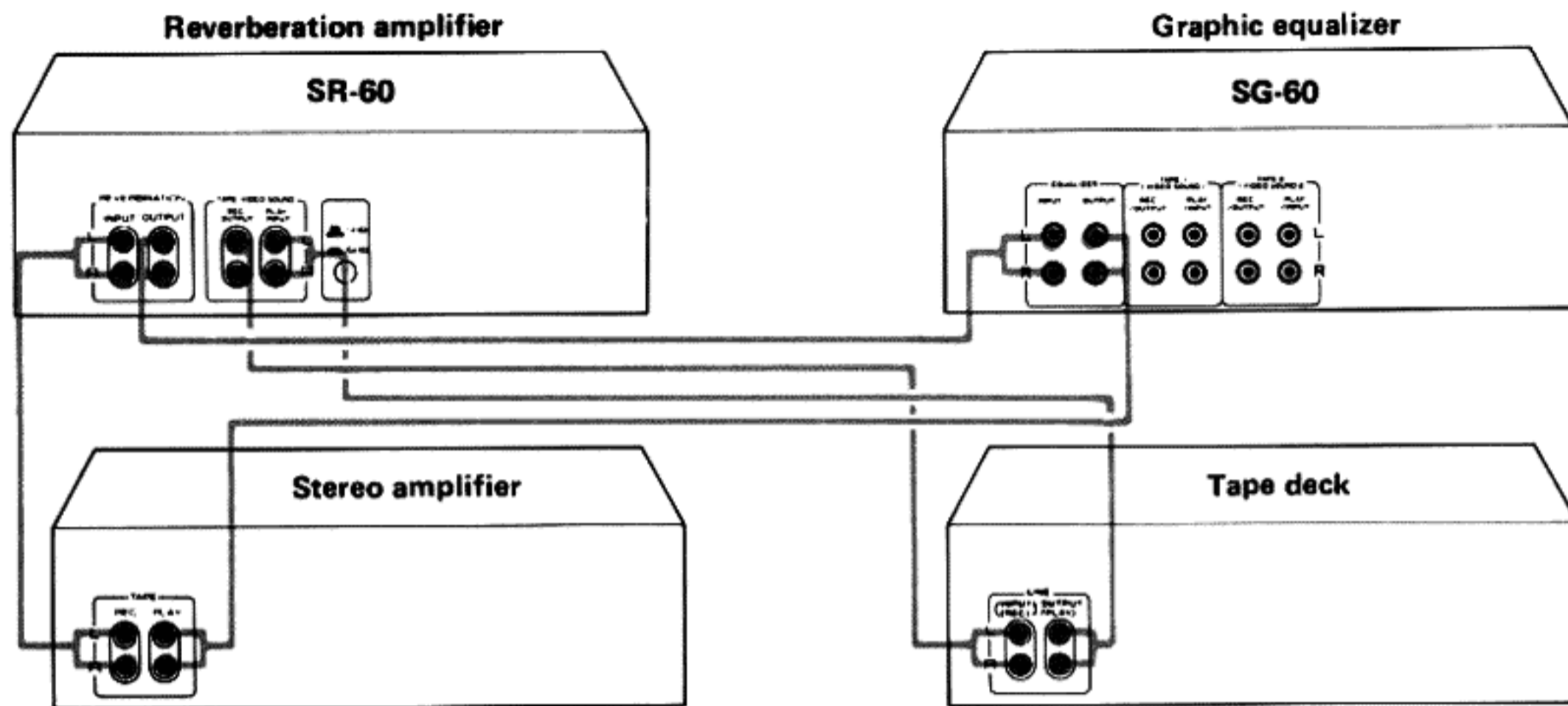

NOTE 1

NOTE 2

	PREMAIN AMP.			SR-60						SG-60			
	FUNCTION	REC OUT	TAPE MONITOR	POWER	TAPE /VIDEO SOUND MONITOR	RE-VERB	EFFECT SELEC-TOR	REVERB LEVEL	LINE OUT	POWER	LINE OUT SELECTOR	INPUT SELECTOR	OCTAVE CONTROLS
Record, AM, FM recording	TAPE 1	PHONO or TUNER	OFF	ON	OFF	PASS	-	-	ON	-	SOURCE	-	-
Record, AM, FM reproduction + Equalizing	TAPE 1	PHONO or TUNER	ON	ON	OFF	PASS	-	-	ON	ON	EQUALIZER	SOURCE	Adjust
Record, AM, FM reproduction + Reverberation	TAPE 1	PHONO or TUNER	ON	ON	OFF	ON	Select	Adjust	ON	-	SOURCE	-	-
Record, AM, FM reproduction + Equalizing + Reverberation	TAPE 1	PHONO or TUNER	ON	ON	OFF	ON	Select	Adjust	ON	ON	EQUALIZER	SOURCE	Adjust
Tape playback	TAPE 1	-	ON	ON	ON	PASS	-	-	OFF	-	SOURCE	-	-
Tape playback + Equalizing	TAPE 1	-	ON	ON	ON	PASS	-	-	OFF	ON	EQUALIZER	SOURCE	Adjust
Tape playback + Reverberation	TAPE 1	-	ON	ON	ON	ON	Select	Adjust	ON	-	SOURCE	-	-
Tape playback + Equalizing + Reverberation	TAPE 1	-	ON	ON	ON	ON	Select	Adjust	ON	ON	EQUALIZER	SOURCE	Adjust

NOTES: 1. When premain amplifiers (A-9, A-8, A-7, A-6, A-5, etc.) equipped with a REC OUT SELECTOR are used.  
2. When other premain amplifiers, receivers, etc. are used.

2. When the SR-60 and RG-60 are used at the same time.

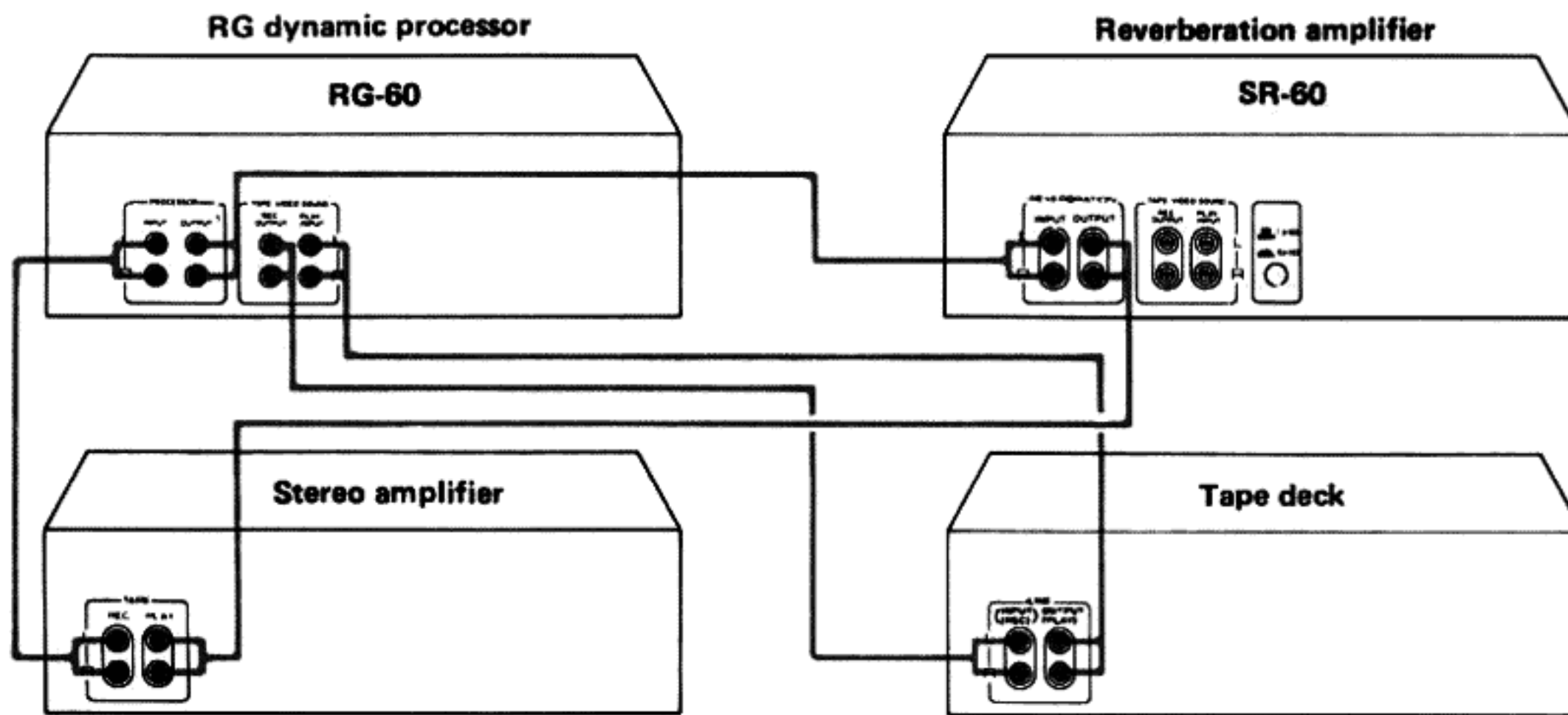

NOTE 1

NOTE 2

NOTE 3

	PREMAIN AMP.			SR-60						RG-60				
	FUNCTION	REC OUT	TAPE MONITOR	POWER	TAPE /VIDEO SOUND MONITOR	RE-VERB	EFFECT SELEC-TOR	REVERB LEVEL	LINE OUT	POWER	PROC-ESSOR	TAPE /VIDEO SOUND MONITOR	DYNAMIC EXPAN-SION	INPUT LEVEL
Record, AM, FM recording	TAPE 1	PHONO or TUNER	OFF	ON	OFF	PASS	-	-	ON	-	PASS	OFF	-	Adjust
Record, AM, FM reproduction + Reverberation	TAPE 1	PHONO or TUNER	ON	ON	OFF	ON	Select	Adjust	ON	-	PASS	OFF	-	Adjust
Record, AM, FM reproduction + Expansion	TAPE 1	PHONO or TUNER	ON	ON	OFF	PASS	-	-	ON	ON	ON	OFF	Adjust	Adjust
Record, AM, FM reproduction + Reverberation + Expansion	TAPE 1	PHONO or TUNER	ON	ON	OFF	ON	Select	Adjust	ON	ON	ON	OFF	Adjust	Adjust
Tape playback	TAPE 1	-	ON	ON	OFF	PASS	-	-	ON	-	PASS	ON	-	Adjust
Tape playback + Reverberation	TAPE 1	-	ON	ON	OFF	ON	Select	Adjust	ON	-	PASS	ON	-	Adjust
Tape playback + Expansion	TAPE 1	-	ON	ON	OFF	PASS	-	-	ON	ON	ON	ON	Adjust	Adjust
Tape playback + Expansion + Reverberation	TAPE 1	-	ON	ON	OFF	ON	Select	Adjust	ON	ON	ON	ON	Adjust	Adjust

- NOTES:
1. When premain amplifiers (A-9, A-8, A-7, A-6, A-5, etc.) equipped with a REC OUT SELECTOR are used.
  2. When other premain amplifiers, receivers, etc. are used.
  3. When the TAPE MONITOR of the premain amplifier is set to ON (or TAPE 1), the RG-60 will not produce a sound if the input level is set to  $-\infty$ . Be sure to adjust the input level control.



**3. When the SR-60, RG-60 and SG-60 are used at the same time.**

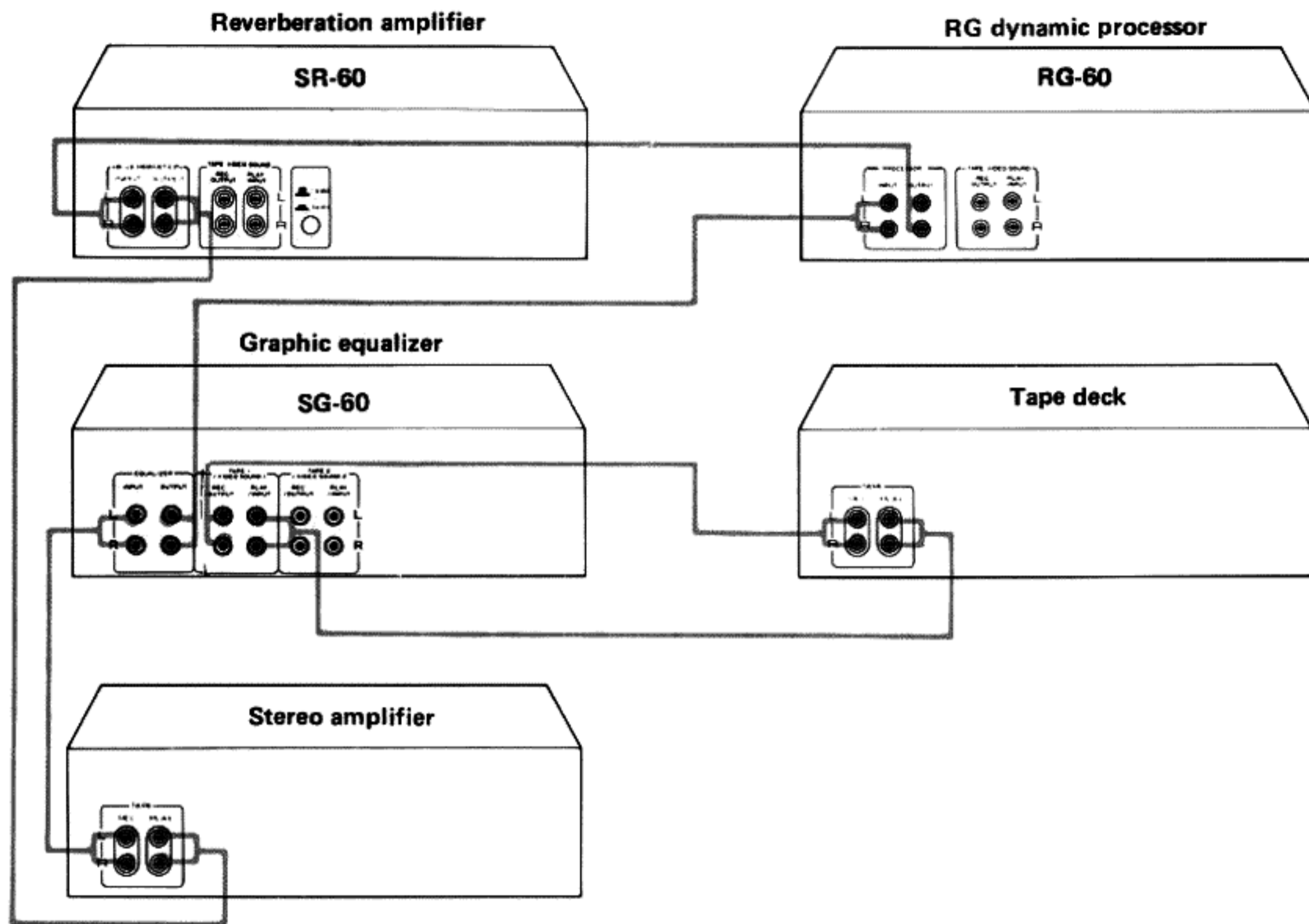

- Shown above is an example where the RG-60 RG dynamic processor ,SG-60 Graphic equalizer and SR-60 Reverberation amplifier are combined. Connect these components properly so you can enjoy the best sounds. For details, see the relevant Operating Instructions.

NOTE 1

NOTE 2

NOTE 3

	PREMAIN AMP.		PRE-MAIN AMP.	SR-60						RG-60					SG-60				
	FUNCTION	REC OUT	TAPE MONITOR	POWER	TAPE /VIDEO SOUND MONITOR	REVERB	EFFECT SELECTOR	REVERB LEVEL	LINE OUT	POWER	PROCESSOR	TAPE /VIDEO SOUND MONITOR	DYNAMIC EXPANSION	INPUT LEVEL	POWER	LINE OUT SELECTOR	INPUT SELECTOR	OC-TAVE CONTROLS	TAPE REC OUT
Record, AM, FM recording	TAPE 1	PHONO or TUNER	OFF	ON	OFF	PASS	-	-	ON	-	PASS	OFF	-	-	-	SOURCE	SOURCE	-	PASS
Record, AM, FM reproduction + Equalizing	TAPE 1	PHONO or TUNER	ON	ON	OFF	PASS	-	-	ON	-	PASS	OFF	-	Adjust	ON	EQUALIZER	SOURCE	Adjust	ON
Record, AM, FM reproduction + Reverberation	TAPE 1	PHONO or TUNER	ON	ON	OFF	ON	Select	Adjust	ON	-	PASS	OFF	-	Adjust	-	SOURCE	SOURCE	-	PASS
Record, AM, FM reproduction + Expansion	TAPE 1	PHONO or TUNER	ON	ON	OFF	PASS	-	-	ON	ON	ON	OFF	Adjust	Adjust	-	SOURCE	SOURCE	-	PASS
Record, AM, FM reproduction + Equalizing + Reverberation	TAPE 1	PHONO or TUNER	ON	ON	OFF	ON	Select	Adjust	ON	-	PASS	OFF	-	Adjust	ON	EQUALIZER	SOURCE	Adjust	ON
Record, AM, FM reproduction + Reverberation + Expansion	TAPE 1	PHONO or TUNER	ON	ON	OFF	PASS	-	-	ON	ON	ON	OFF	Adjust	Adjust	ON	EQUALIZER	SOURCE	Adjust	ON
Record, AM, FM reproduction + Reverberation + Expansion	TAPE 1	PHONO or TUNER	ON	ON	OFF	ON	Select	Adjust	ON	ON	ON	OFF	Adjust	Adjust	-	SOURCE	SOURCE	-	PASS
Record, AM, FM reproduction + Equalizing + Reverberation + Expansion	TAPE 1	PHONO or TUNER	ON	ON	OFF	ON	Select	Adjust	ON	ON	ON	OFF	Adjust	Adjust	ON	EQUALIZER	SOURCE	Adjust	ON
Tape playback	TAPE 1	-	ON	ON	OFF	PASS	-	-	ON	-	PASS	OFF	-	Adjust	-	TAPE 1	-	-	-
Tape playback + Equalizing	TAPE 1	-	ON	ON	OFF	PASS	-	-	ON	-	PASS	OFF	-	Adjust	ON	EQUALIZER	TAPE 1	Adjust	-
Tape playback + Reverberation	TAPE 1	-	ON	ON	OFF	ON	Select	Adjust	ON	-	PASS	OFF	-	Adjust	-	TAPE 1	-	-	-
Tape playback + Expansion	TAPE 1	-	ON	ON	OFF	PASS	-	-	ON	ON	ON	OFF	Adjust	Adjust	-	TAPE 1	-	-	-
Tape playback + Reverberation + Equalizing	TAPE 1	-	ON	ON	OFF	ON	Select	Adjust	ON	-	PASS	OFF	-	Adjust	ON	EQUALIZER	TAPE 1	Adjust	-
Tape playback + Equalizing + Expansion	TAPE 1	-	ON	ON	OFF	PASS	-	-	ON	ON	ON	OFF	Adjust	Adjust	ON	EQUALIZER	TAPE 1	Adjust	-
Tape playback + Reverberation + Expansion	TAPE 1	-	ON	ON	OFF	ON	Select	Adjust	ON	ON	ON	OFF	Adjust	Adjust	-	TAPE 1	-	-	-
Tape playback + Reverberation + Expansion + Equalizing	TAPE 1	-	ON	ON	OFF	ON	Select	Adjust	ON	ON	ON	OFF	Adjust	Adjust	ON	EQUALIZER	TAPE 1	Adjust	-

- NOTE: 1. When premain amplifiers (A-9, A-8, A-7, A-6, A-5, etc.) equipped with a REC OUT SELECTOR are used.  
 2. When other premain amplifiers, receivers, etc. are used.  
 3. When the TAPE MONITOR of the premain amplifier is set to ON (or TAPE 1), the RG-60 will not produce a sound if the input level is set to -∞. Be sure to adjust the input level control.

# BLOCK DIAGRAM

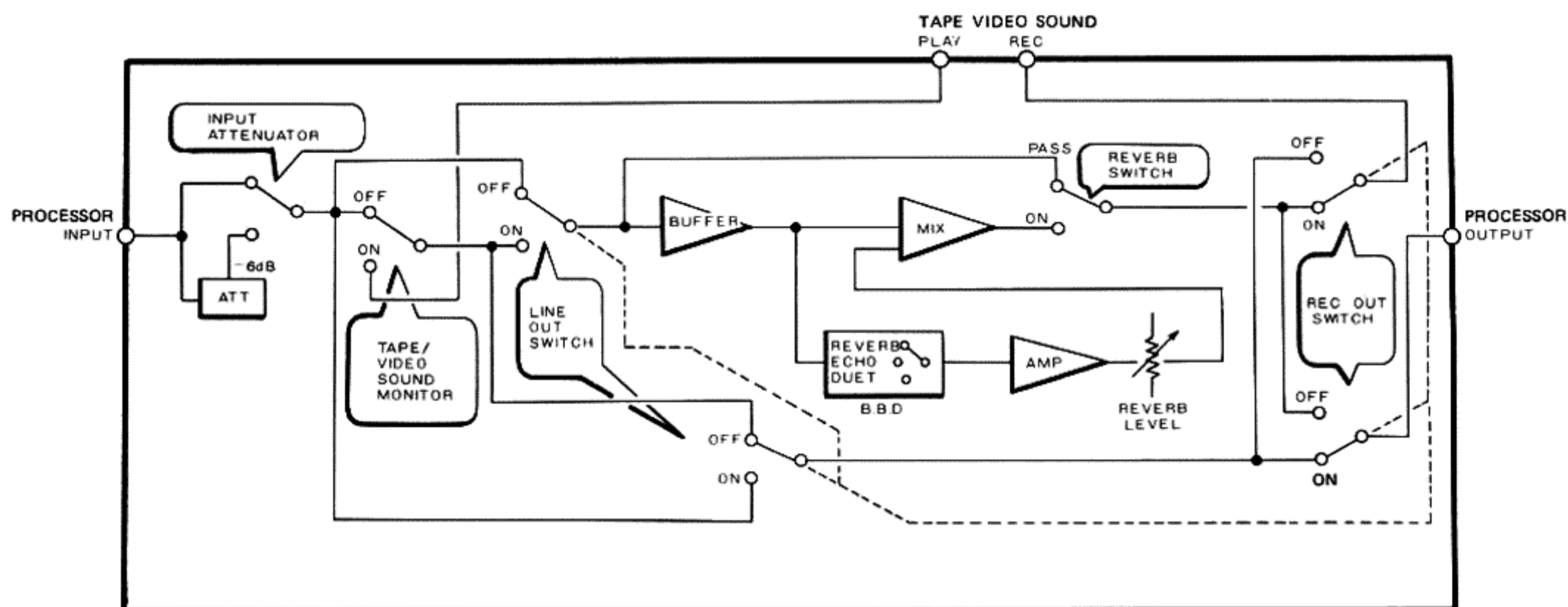

# SPECIFICATIONS

## Reverberation Amplifier Section

Reverb time (REVERB) 400Hz	0~3 sec
Reverb time (ECHO) 400Hz	0~3 sec
Delay time (DUET) 400Hz	100 m/sec
Input (Sensitivity/Impedance)	150mV/50kΩ
	(at 1kHz, REVERB LEVEL volume: 0)
Frequency Response	10Hz to 70kHz $\begin{matrix} +0 \\ -1 \end{matrix}$ dB
	(at REVERB LEVEL volume: 0)
Total Harmonic Distortion	0.005%
	(at 1kHz, 1V, REVERB LEVEL volume: 0)
Maximum Output Level	6.5V
	(at 1kHz, 0.01%, REVERB LEVEL volume: 0)
Signal to Noise Ratio (IHF A Network, short circuit)	
	at 1V, REVERB LEVEL volume: 0 ..... 98dB
	at 2V, REVERB LEVEL volume: 0 ..... 104dB
Output (level/Impedance)	
REVERBERATION OUTPUT	150mV/220Ω
	(at 1kHz, REVERB LEVEL volume: 0)
TAPE REC	150mV/220Ω

## Miscellaneous

### Power Requirements

KU, KC models	AC120 Volts, 60Hz
S, S/G models	~AC110V/120V/220V/240V
	(switchable), 50/60Hz

HB model ..... a.c. 240 Volts~50/60Hz

YP model ..... a.c. 240 Volts~50Hz

Power Consumption ..... 25 Watts

Dimensions ..... 420 (W) x 99 (H) x 340 (D) mm

16-9/16 (W) x 3-7/8 (H) x 13-3/8 (D) in

Weight (without package) ..... 4.6kg (10 lb 2 oz)

### Furnished Parts

Connection cord with pin plugs ..... 2

Operating instructions ..... 1

### NOTE:

*Specifications and the design are subject to possible modification without notice, due to improvements.*

**PIONEER ELECTRONIC CORPORATION** 4-1, Meguro 1-Chome, Meguro-ku, Tokyo 153, Japan

**PIONEER ELECTRONICS (USA) INC.** P.O. Box 1760, Long Beach, California 90801 U.S.A.

TEL: (800) 421-1404, (213) 420-5914

**PIONEER ELECTRONIC (EUROPE) N.V.** Keetberglaan 1, 2740 Beveren, Belgium TEL: 03/775-28-08

**PIONEER ELECTRONICS AUSTRALIA PTY. LTD.** 178-184 Boundary Road, Braeside, Victoria 3195, Australia

TEL: (03) 580-9911

<ARB-580-C>

<84J02Y5S10>