

HIGH-FIDELITY AUTOMATIC  
STEREO TURNTABLE

# PL-A35

PV  
PVT



OPERATING INSTRUCTIONS

**PIONEER**

---

Thank you for the confidence you have shown us in purchasing this Pioneer Fully Automatic Stereo Turntable. For the benefit of using your favorite stereo phono cartridge, the PL-A35 is not equipped with a factory-mounted cartridge. Although any standard stereo phono cartridge can be mounted, we recommend the use of a high-quality magnetic type cartridge.

## FEATURES

### PROFESSIONAL PERFORMANCE YET EFFORTLESS OPERATION

This Pioneer model combines studio-quality performance with the operational ease of a fully automatic. Simply flick the function lever to START position once, and the tonearm will be automatically moved over and lowered onto the record and, at the end of the disc, will return automatically to its rest. One-touch CUT and REPEAT features let you interrupt and repeat any record freely.

### SYNCHRONOUS MOTOR AND BELT DRIVE

The turntable platter is driven by a synchronous 4-pole motor of excellent stability independent from power voltage fluctuations. The drive belt is precision-finished on both sides, a feature that helps reduce wow and flutter to an absolute minimum. (The tonearm is moved by a separate, geared motor.)

### ANTI-SKATING DEVICE

Model PL-A35 features an effective countermeasure against skating (excess pressure of the stylus against the inner wall of the record groove).

The anti-skating device keeps the stylus correctly balanced in the groove and assures perfect tracking.

### DIRECTLY READABLE TRACKING FORCE ADJUSTMENT

The tracking force is adjustable over a wide range so that practically any cartridge (with standard EIA plug) can be accommodated. The balance weight is equipped with a gauge for easy, direct reading of the tracking force.

### HIGH QUALITY MAGNET-TYPE CARTRIDGE SUPPLIED

The supplied cartridge, Pioneer model PC-50, is a magnetic type of very true-to-the-record sound quality and a frequency response from 10 to 25,000 Hz. Its stylus is a durable diamond type.

### "FREE HINGE" DUST COVER

The transparent dust cover is held by spring-loaded hinges and can be arrested in any desired position. If desired, it can be removed altogether.

### OILED WALNUT BASE

Adds an extra touch of value and elegance to your stereo installation.

## INSTALLATION

Install the PL-A35 with the following points in mind.

- The place must be well-ventilated and free from humidity and dust.
- The unit should not be exposed to direct sunlight.
- The unit should not be placed near any source of heat.
- The unit should be placed as far from the speaker systems as possible.

## TYPICAL STEREO SETUP

The diagram shows a typical installation, and the relationship of turntable, amplifier or receiver and speakers (Fig. 1).

## LINE VOLTAGE AND FREQUENCY

Confirm the line voltage and frequency of your house current before turning power on, because your PL-A35 may not be conditioned for operation with the local line voltage and frequency.

### LINE VOLTAGE

- The LINE VOLTAGE SELECTOR SWITCH, provided inside the turntable, can be seen when the bottom plate is opened.
- Fig. 2 shows the location of the line voltage selector switch and metal stopper. Remove the screw, to free the metal stopper.
- Set the selector switch to the local voltage, hold the switch in position with the metal stopper, and tighten the screws.

### AC FREQUENCY (CYCLES)

The speed of the motor depends upon the frequency (cycles) of the AC power supply, which can be either 60Hz (USA, etc.) or 50Hz (most European countries, etc.).

The turntable is, of course, factory-adjusted for the AC frequency of the country to which it is being shipped. So, no readjustment is usually required if you use the unit in the same country or area where you bought it.

If you move to another country or region, however, please find out if the AC frequency is the same as at your former place of residence — if so, no problem. If it is different, your turntable must be readjusted as follows:

1. Remove the turntable platter. Now the motor pulley is accessible. The pulley is fastened to the motor shaft by one little screw. Remove this with the supplied screwdriver, and remove the pulley.
2. Set the speed selector lever at 33 RPM position.
3. Attach the supplied spare motor pulley and fasten it with the screw removed in step 1. Do not tighten the screw firmly, yet. Then set the turntable platter on the unit and lead the drive belt around the pulley.
4. The belt should be positioned in the belt guide and around the center of the upper (smaller) part of the motor pulley. To achieve this, it may be necessary to loosen the pulley once more and adjust its height. See Fig. 3.
5. Turn the unit on and confirm that the belt travels smoothly through the belt guide and around the pulley.

### HOW TO DISTINGUISH THE MOTOR PULLEYS

- Pulley for 50Hz AC: larger diameter  
 Pulley for 60Hz AC: smaller diameter, also has a groove in its lower part.

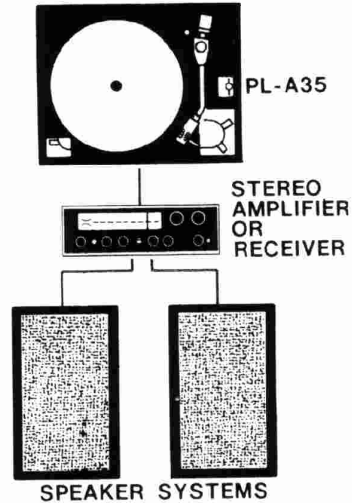

Fig. 1

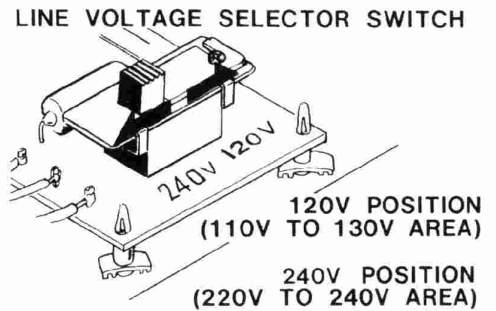

Fig. 2

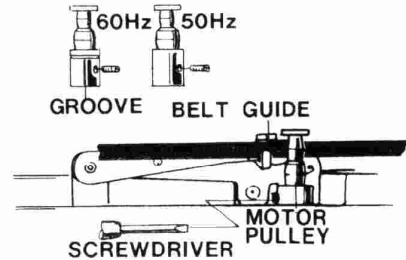

Fig. 3

**ARM HEAD**

Insert the arm head into the tonearm sleeve and lock it in place by turning the locking collar (Fig. 9). Then, untie the ribbon fastening the tonearm to the arm rest.

**NOTE:** In some parts of the world, model PL A35 is delivered without cartridge. If yours is one of these, purchase any high quality magnetic type stereo cartridge and install it as described in paragraph "EXCHANGING THE CARTRIDGE" below.

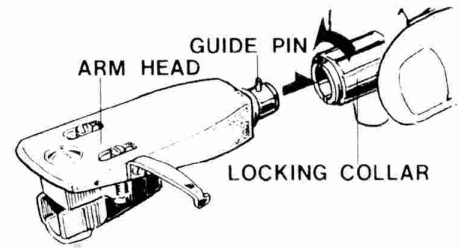

Fig. 9

**DUST COVER**

Attach the plastic dust cover by sliding the cutouts in the fasteners (on the cover) over the hinge pegs (on the base) as shown in Fig. 10. The hinge is designed to hold the cover open at any angle from 30° to 60°.

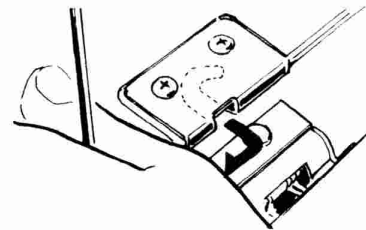

Fig. 10

**EXCHANGING THE CARTRIDGE**

When changing a cartridge, be sure to connect the lead wires correctly between cartridge pins and pin plug. After a cartridge has been mounted in the arm head, the arm overhang must be readjusted as follows: First, tighten the cartridge mounting screws somewhat but not completely. Then, inch the cartridge back and forth to obtain proper overhang, and finally tighten the screws securely (Figs. 11 and 12).

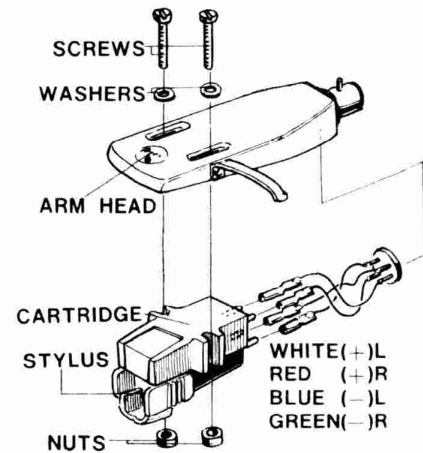

Fig. 11

**CONNECTION TO STEREO AMPLIFIER OR RECEIVER**

The cartridge supplied with the PL-A35 is an induced magnet type. Use the PHONO MAG input jacks of your amplifier for connection to the PL-A35.

- Connect the lead marked "L" to the left channel input jack and the lead marked "R" to the right channel jack. The third wire is a ground lead with a split lug on its end. Connect the split lug to the ground terminal on the amplifier (Fig.13).

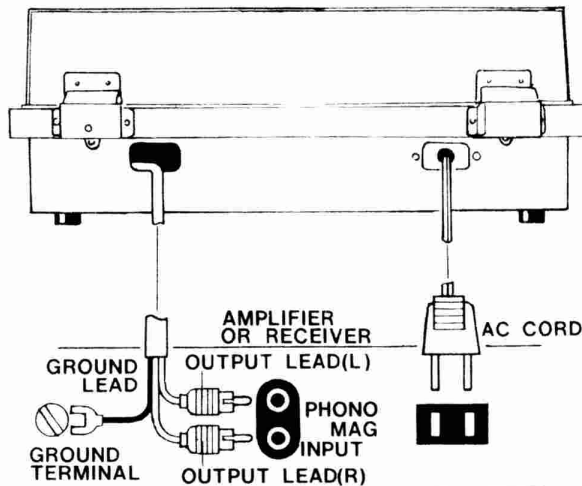

Fig. 13

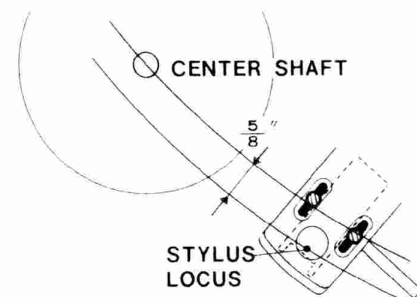
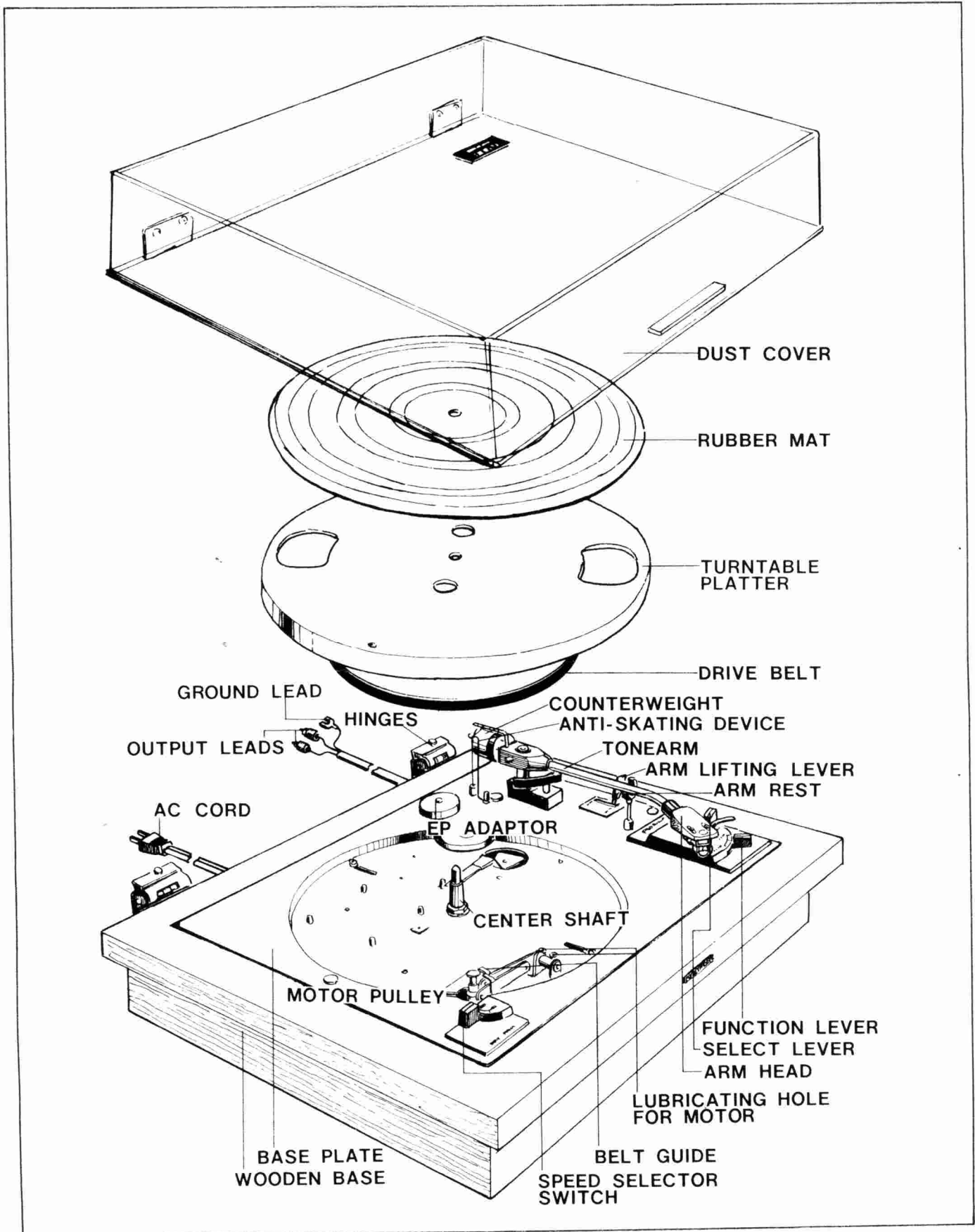

Fig. 12

**PLUGGING AC CORD**

If the AC cord plugging should cause much hum, re-plug the cord with its plug-pins reversed and such hum may be eliminated.



## ADJUSTMENTS

### TRACKING FORCE ADJUSTMENTS

With the tonearm off the arm rest, turn the counterweight in either direction until the tonearm is in perfect horizontal balance. A tracking force dial ring is provided at the front of the counterweight. While holding the counterweight in position, turn the dial ring until the 0 mark on the dial aligns with the black index line engraved on the tonearm. The tracking force is now zero (Fig. 14).

Now, turn the counterweight together with the tracking force dial (the dial is calibrated up to 4 grams in steps of 0.5 gram).

Set the tracking force at 1.5 ~ 2.1 grams which is optimum for the supplied PC-50 cartridge.

When using another type of cartridge, adjust the tracking force according to the instructions supplied by the cartridge manufacturer (Fig. 15).

### ANTI-SKATING DEVICE

Bar "B" of the anti-skating device has five thread positions corresponding to tracking force values as shown in Fig. 16. If the tracking force is 1.5 to 2 grams, for example, the thread with the aluminum-made weight furnished must be set in the 1st notch on the bar arm, if the tracking force is 2.1 to 2.5 grams, the thread with the brass-made weight furnished, too, must be set in the 2nd notch.

### ARM ELEVATION ADJUSTMENT

The tonearm is raised and lowered by the arm elevator under control of the function and tonearm lifting levers. The elevation, i.e. the stroke for the tonearm to travel up and down, can be adjusted by loosening the screw shown in Fig. 17. Usually, this adjustment is not required.



Fig. 14

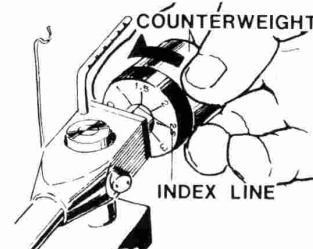

Fig. 15

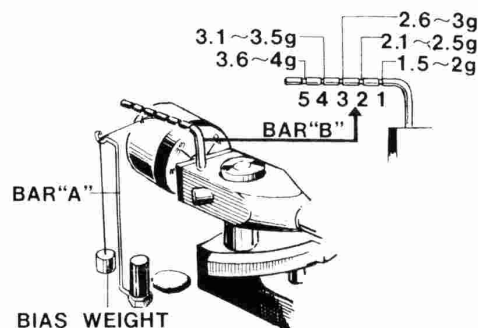

Fig. 16

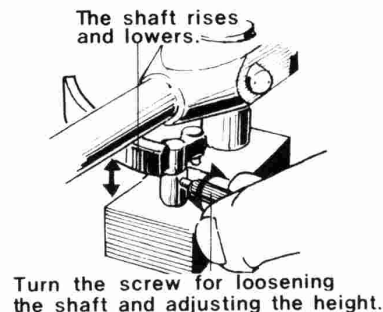

Fig. 17

# OPERATING CONSIDERATIONS

## CORRECT HANDLING OF FUNCTION LEVER

Always move function lever quickly and release it immediately. Do not touch the tonearm while it is in motion.

## KEEP THE STYLUS ALWAYS CLEAN

Dust on the stylus affects the sound quality. Clean the stylus frequently with a soft brush. Care must be taken not to touch it with your fingers. Also, the records must be kept clean.

## CHANGE TURNTABLE SPEED ONLY WHEN THE TURNTABLE IS ROTATING

In the belt drive system, the turntable speed is changed by shifting the belt up or down on the stepped motor pulley by the speed selector switch. The speed can be changed only while the turntable is rotating.

## NEVER OBSTRUCT THE ROTATING TURNTABLE BY HAND

Stopping the rotating turntable by hand may cause the belt to move off the pulley and can lead to stretching of the belt.

## AVOID SHOCKS AND VIBRATION

Model PL-A35 operates with a very small stylus tracking force. It should be in a stable position. Also, keep the unit as far apart from the loudspeakers as possible.

# OPERATION

## SPEED SELECTOR SWITCH

Speed can be changed only while turntable platter is rotating.

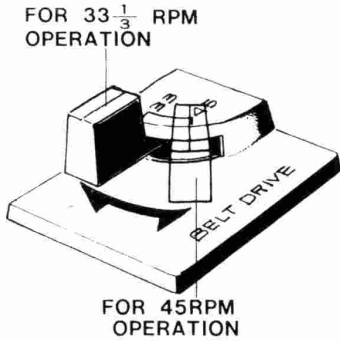

## ARM LIFTING LEVER

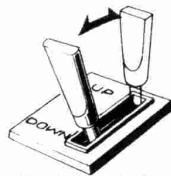

UP..... Set the lever in this position when you wish to stop playing the record temporarily.  
DOWN - Set the lever in this position normally.

## ARM REST

Adjust arm rest to same height as tonearm elevator.

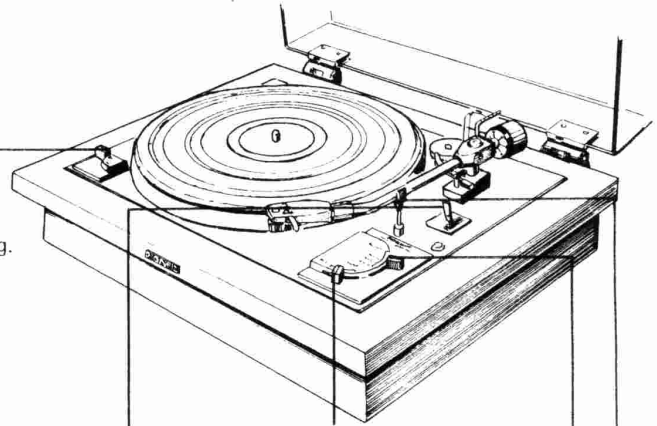

## FUNCTION LEVER

START/CUT.....For starting record play and stopping it in midway.  
REPEAT.....For playing the same record repeatedly.

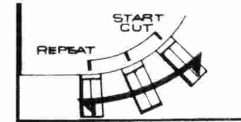

## SELECT LEVER

MANUAL.....For manual operation  
12" 30 .....For playing 12 (30cm)  
10" 25 .....For playing 10 (25cm)  
7" 17 .....For playing 7 (17cm)  
LP or EP record

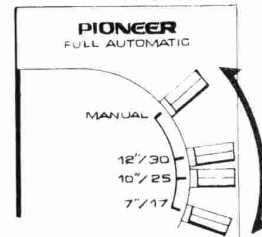

### AUTOMATIC PLAY

1. Make sure that the arm lifting lever is in **DOWN** position.
2. Set the select lever to the size of the record to be played: 12" (30cm), 10" (25cm) or 7" (17cm).
3. Check the position of the speed selector switch. If record speed and speed selector switch do not agree, reset the speed selector lever as follows:
  - (A) Set the select lever to **MANUAL** position.
  - (B) Set the function lever to **START/CUT** position and immediately release the lever. The turntable will start rotating. Then set the speed selector lever to the correct speed.
  - (C) Move the function lever to **START/CUT** position again. The turntable will stop.

**NOTES:**

- The speed select lever must be reset only while the turntable is rotating.
- Whenever the turntable is rotated for a speed change be sure to keep the select lever in **MANUAL** position.

4. Free the stylus cover from the stylus by pulling it forward.
5. Set the function lever to **START/CUT** position. The turntable will begin rotating, and the tonearm will automatically move over and float down onto the record.
6. At the end of the record, the tonearm will automatically return to the arm rest and the turntable will stop.

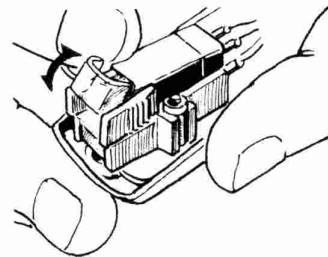

Fig. 18

### STARTING THE PLAY FROM A POINT MIDWAY IN THE RECORD OR MANUAL PLAY

1. Set the select lever to **MANUAL** position, the arm lifting lever to **DOWN**.
2. Move the tonearm over the spot from which you want to play the record.
3. Set the function lever to **START/CUT** position, then release it. The tonearm will float down onto the record.
4. When playback ends, the tonearm will automatically return to the arm rest, and the turntable will stop.

### INTERRUPTING PLAYBACK

To interrupt playback, move the function lever to **START/CUT** position and release the lever. The tonearm will return to the arm rest and the turntable platter will stop.

### REPEAT PLAYBACK

With the function lever set the **REPEAT** position, the unit will automatically repeat the same record again and again.

### ARM LIFTING LEVER

This lever is used to lift and lower the tonearm. Setting the lever to **DOWN** position will quietly float the arm down, and **UP** position will float the arm up from the record. Normally, the lever should be set to **DOWN** position.



## STYLUS REPLACEMENT

The stylus that comes with the unit is a diamond tip, PN-50. It should last about 1,200 to 1,500 hours of operation. Don't use the stylus longer than that because a worn stylus may damage the records or produce distorted sound. When replacing the stylus, unplug the arm head from the arm, and pull out the stylus together with its holder diagonally. Replace the stylus unit with a new one (Fig.19).

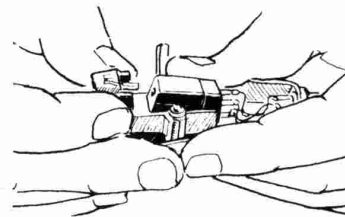

Fig. 19

## STYLUS DROP POINT ADJUSTMENT

It is not usually necessary to readjust the stylus drop point. If necessary, remove the rubber bush and with the tonearm resting on the arm rest, set the select lever to 12," 10," or 7" position and adjust the adjusting screw with a screwdriver. If the stylus touches down too far out, turn the screw clockwise; and if the stylus touches too far in, turn the screw counterclockwise (Fig. 20).

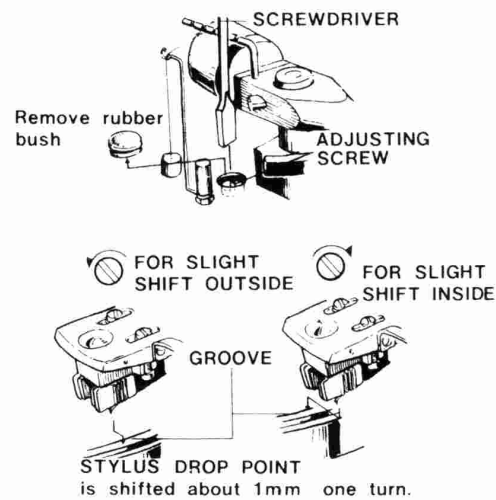

Fig. 20

## LUBRICATION

Mechanical noises, wow and flutter usually result from lack of lubricant in rotating parts. In extreme cases, lack of lubricant may cause the motor to freeze. Lubricate the specified spots at least once every two months if the PL-A35 under regular home use. One lubricating point is shown in Fig. 21. Also lubricate the center shaft of the turntable. Apply one or two drops of oil. Care must be taken not to put any oil on the motor pulley or belt. If this should happen, wipe with a soft cloth moistened with alcohol.

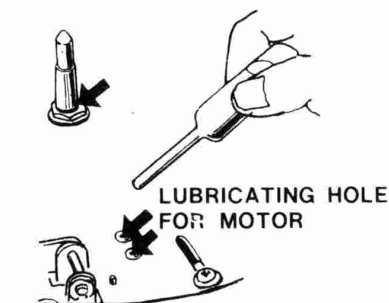

Fig. 21

## SPECIFICATIONS

### MOTOR AND TURNTABLE

Motor:	4-pole synchronous motor
Turntable drive:	Belt-driven
Speed:	Two speeds, 33 1/3 and 45rpm
Speed accuracy:	1.0% or less
Wow and flutter:	0.1% (WRMS) or less
S/N:	47dB or more
Turntable platter:	12" (30cm) diameter aluminum alloy

### ONEARM

Tonearm type:	Static balance type, pipe arm (S-shaped)
Effective arm length:	221mm
Usable cartridge weight:	4 ~ 10g
Furnished cartridge:	PC-50

### SUBFUNCTIONS

Anti-skating device control  
 Fully automatic tonearm  
 Light aluminum head shell plug-in type  
 Dust cover with free stop hinge  
 Wooden base with anti-acoustic feedback suspension  
 Counterweight with tracking force adjustment gauge  
 Hydraulic cueing device

### FURNISHED ACCESSORIES BIAS WEIGHT

Lubricator	1	EP abapotor	1
Screwdriver	2	Motor pulley	1
Bias weight:		Brass-made	1
		Aluminum-made	1

### MISCELLANEOUS

Power requirements:	AC, 110, 117, 130, 220 or 240V. 60Hz, 50Hz
Power consumption:	19W MAX.
Dimensions:	18-7/8(W) x 16-3/8(D) x 7-3/16(H) in. 480(W) x 415(D) x 183(H) mm
Weight:	19 lb 14oz. 9kg

### FURNISHED CARTRIDGE

Type:	Induced magnet type (PC-50)
Frequency response:	10Hz to 25,000Hz
Channel separation:	More than 25dB at 1,000Hz
Output voltage:	3mV at 1,000Hz (5cm/sec. or 2 ips)
Load impedance:	50k $\Omega$
Stylus:	0.5 mil diamond (PN-50)
Compliance:	12 x 10 <sup>-6</sup> cm/dyne at 100Hz (dynamic)
	22 x 10 <sup>-6</sup> cm/dyne (static)
Tracking force:	1.5 to 2.1 g
Weight:	0.21 oz 6g
Mounting:	Conforms to the EIA standards 1/2 inch (12.7 mm)

**NOTE:** Specifications and the design subject to possible modifications without notice due to improvements.

**PIONEER ELECTRONIC CORPORATION**

15-5, 4-Chome, Ohmori-nishi, Ohta-ku, Tokyo, Japan

**U.S. PIONEER ELECTRONICS CORPORATION**

178 Commerce Road, Carlstadt, New Jersey 07072 U.S.A.

**PIONEER ELECTRONIC (EUROPE) N.V.**

Meir-center, Meir 21, 2000 Antwerp, Belgium