

 **PIONEER®**

# Service Manual

**CIRCUIT & MECHANISM  
DESCRIPTIONS**

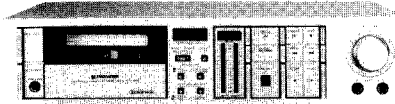

*Shown in this photo is Model CT-40.*

**ORDER NO.  
ARP-369-0**

**STEREO CASSETTE TAPE DECK**

# CT-40

**CT-940**

**CT-30**

**CT-740**

**CT-20**

**CT-540**

## CONTENTS

1. MODEL COMPARISONS .....	2
2. BLOCK DIAGRAMS .....	3
3. CIRCUIT DESCRIPTIONS .....	8
4. MECHANICAL OPERATIONS .....	18

[www.manualscenter.com](http://www.manualscenter.com)

**PIONEER ELECTRONIC CORPORATION** 4-1, Meguro 1-Chome, Meguro-ku, Tokyo 153, Japan  
**PIONEER ELECTRONICS (USA) INC.** 1925 E. Dominguez St., Long Beach, California 90810 U.S.A.  
**PIONEER ELECTRONIC (EUROPE) N.V.** Keetberglaan 1, 2740 Beveren, Belgium  
**PIONEER ELECTRONICS AUSTRALIA PTY. LTD.** 178-184 Boundary Road, Braeside, Victoria 3195, Australia

# 1. MODEL COMPARISONS

The same tape transport mechanism and basic electrical circuits are used in the CT-20, CT-30, CT-40, CT-540, CT-740, and CT-940. The different features included in each model are listed in Fig. 1-1 below.

- CT-40 and CT-940 differ only in style design (color). The mechanism and electrical circuits are identical.
- The CT-740 differs from the CT-940 in that the tape counter is a mechanical type, the Dolby NR system is type B only, and the headphones output has been omitted.
- The CT-30 differs from the CT-40 in that the MS (Music Search) and REC MUTE functions have been omitted, and the tape counter is mechanical.
- The CT-20 differs from the CT-30 in that the Dolby NR system is type B only.
- The CT-540 differs from the CT-740 in that the MS and REC MUTE functions have been omitted.

The export destinations for each model are listed in Fig. 1-2.

	CT-40	CT-940	CT-740	CT-30	CT-20	CT-540
MS (Music Search) function	○	○	○	—	—	—
REC MUTE (Unrecorded blank creation) function	○	○	○	—	—	—
B & C types Dolby NR system	○	○	—	○	—	—
B type Dolby NR system	—	—	○	—	○	○
Electronic tape counter (four figures LED numeric display)	○	○	—	—	—	—
Mechanical tape counter (three figures)	—	—	○	○	○	○
Headphones output	○	○	—	○	○	—

Fig. 1-1 Different features list

Type	Model						Remarks
	CT-40	CT-940	CT-740	CT-30	CT-20	CT-540	
KU	○	○	○	○	○	○	U.S.A. model
KC	○	—	—	—	○	○	Canada model
HE	—	○	○	—	—	○	European continent model
HB	—	○	○	—	—	○	United Kingdom model
HP	○	○	—	○	○	○	Australia model
D	○	○	—	○	○	○	General export model
D/G	—	—	—	—	○	—	U.S. Military model

Fig. 1-2 Export destinations list

## 2. BLOCK DIAGRAMS

### 2.1 FOR MODELS CT-40 AND CT-940

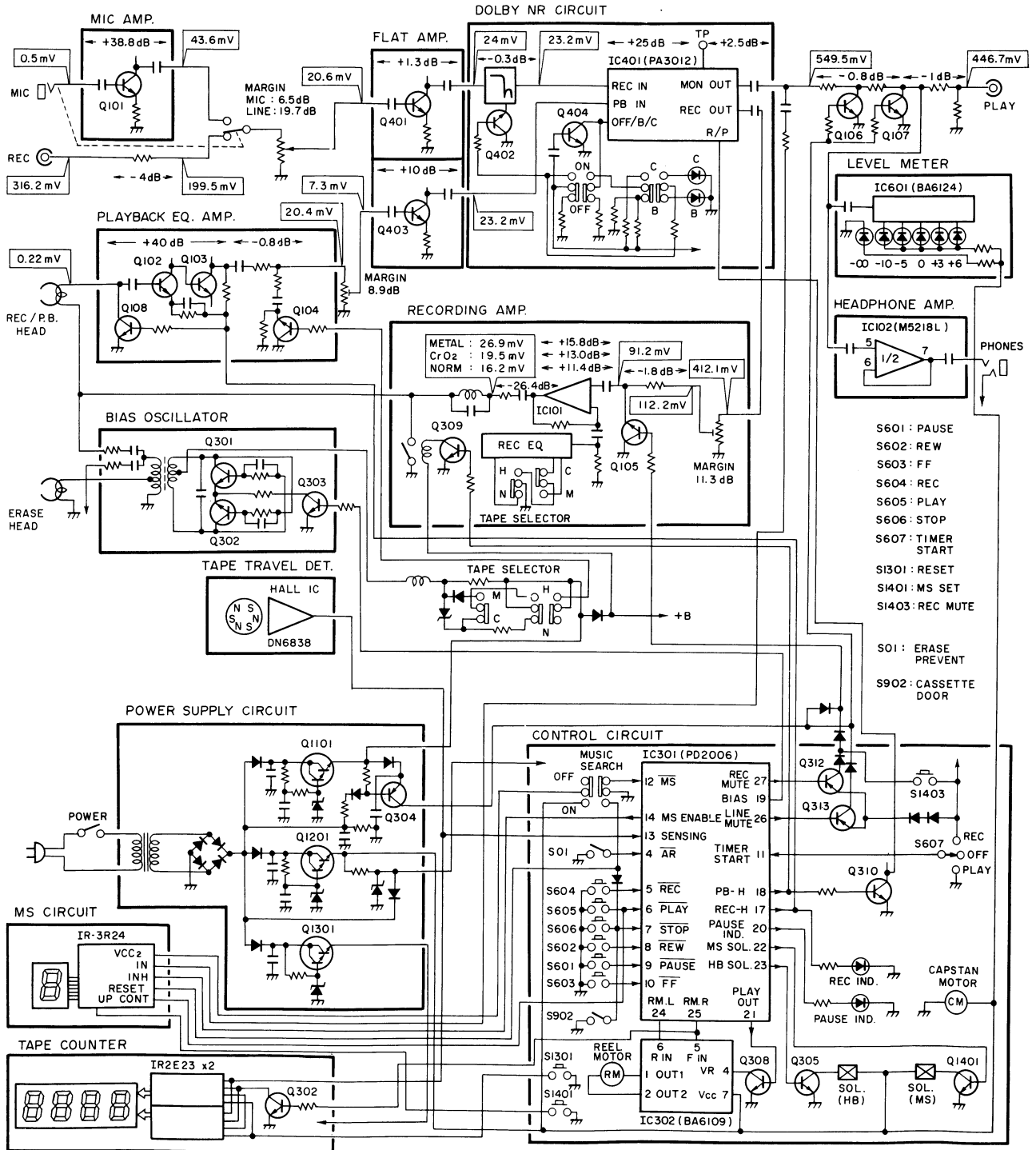

2.2 FOR MODEL CT-740

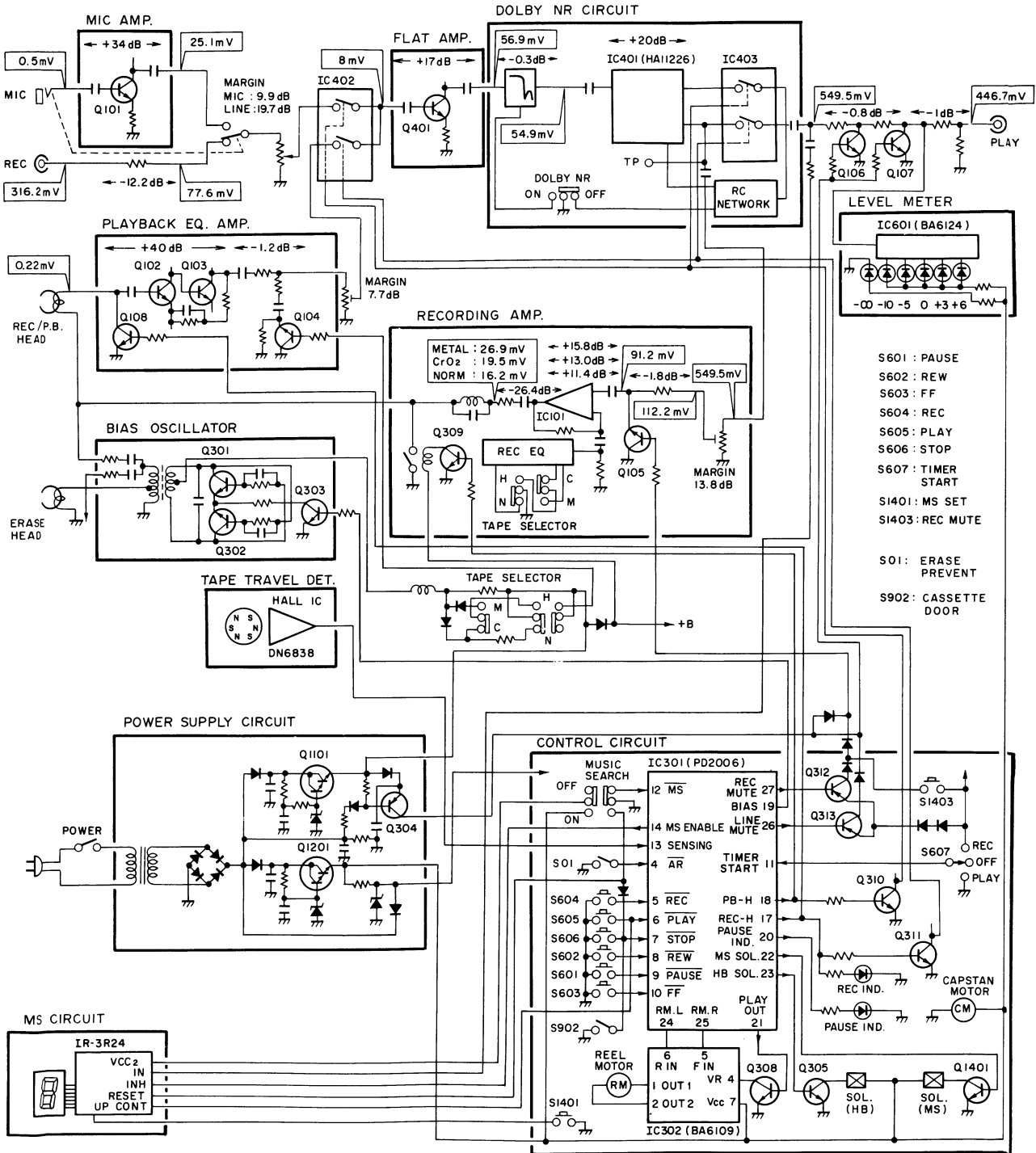



2.3 FOR MODEL CT-30

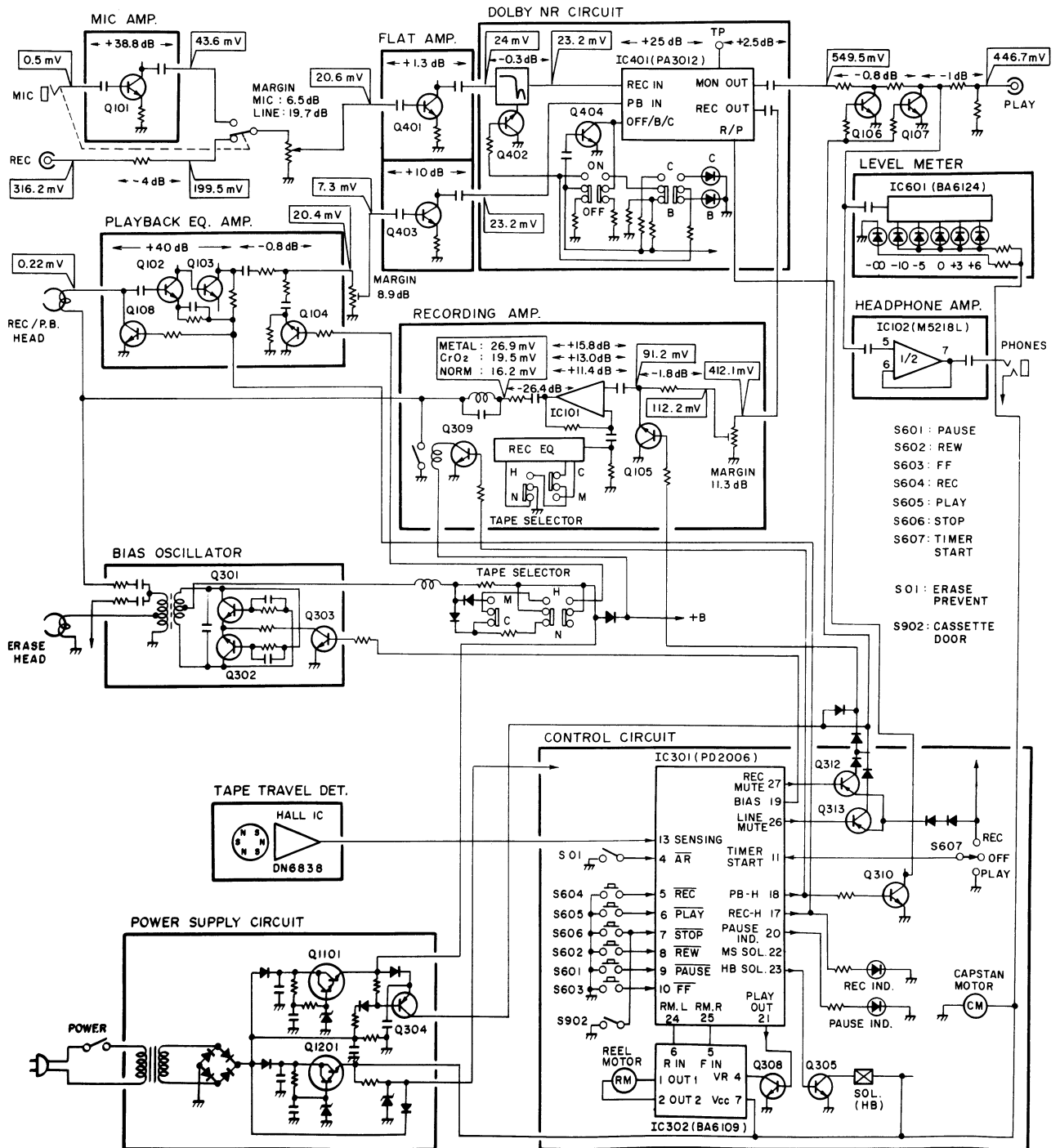

2.4 FOR MODEL CT-20

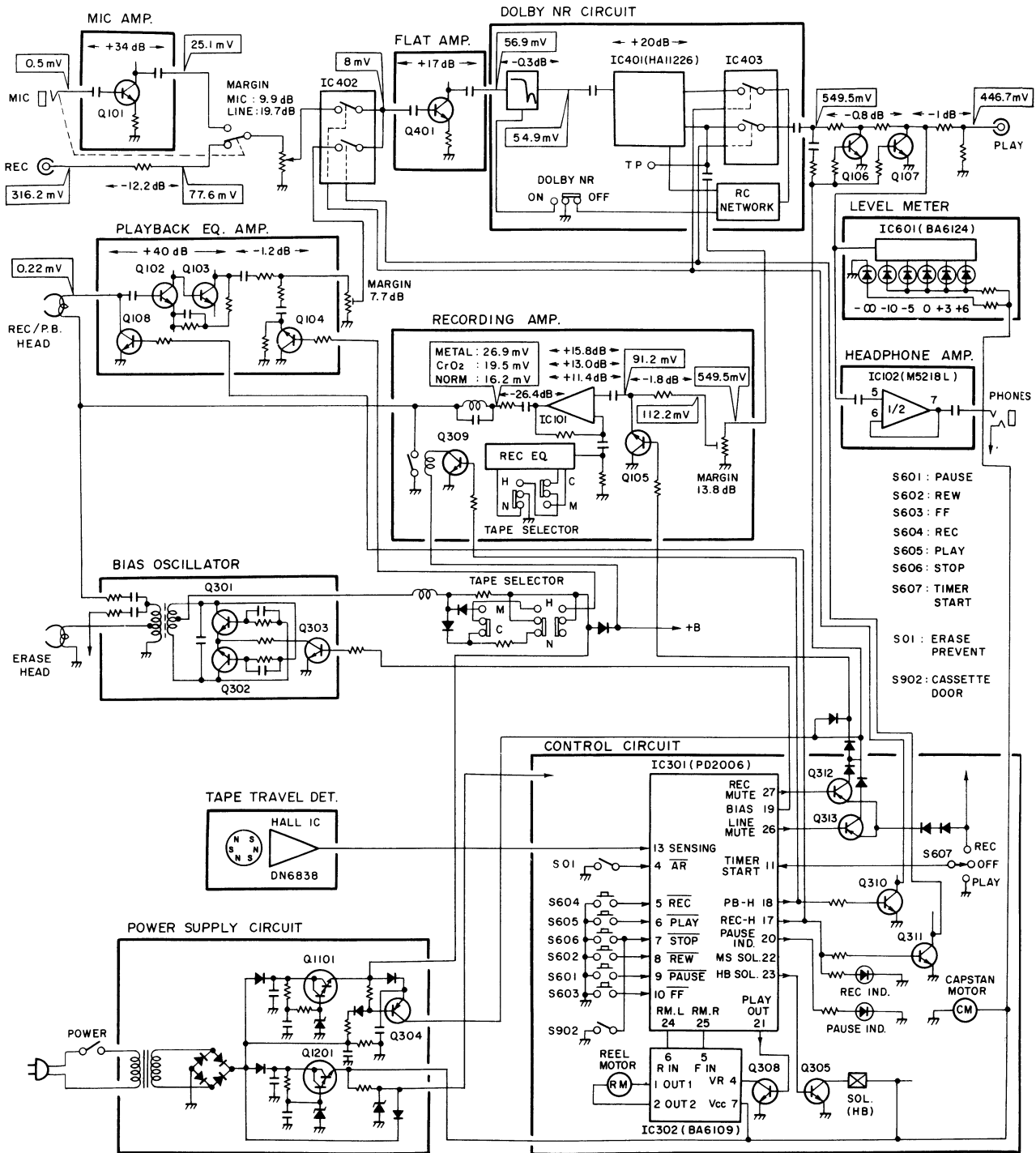

2.5 FOR MODEL CT-540

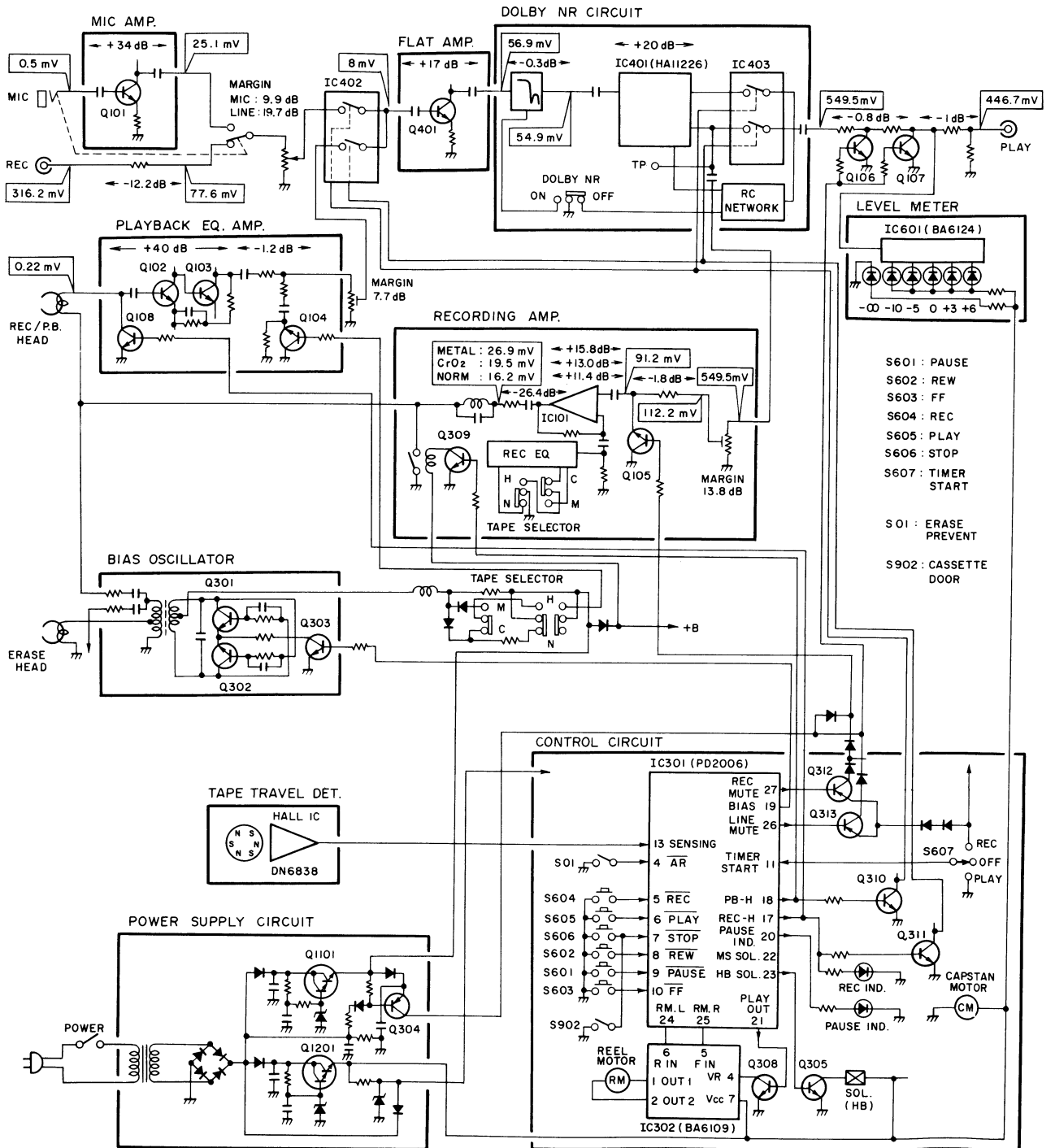

### 3. CIRCUIT DESCRIPTIONS

#### 3.1 OUTLINE OF MAIN STAGE

##### Playback Equalizer Circuit

The equalizer amplifier is a two-stage direct-coupled amplifier where the playback equalization for NORM tapes is achieved by NFB. Equalization for CrO<sub>2</sub> and METAL tapes is achieved by transistor switching of an RC network connected to the output of the equalizer amplifier.

##### Dolby Noise Reduction System

##### • CT-30, CT-40, and CT-940

These tape decks incorporate the type B and type C NR systems and the recording/playback switching in a single IC (PA3012). No adjustments are required. The type C Dolby noise reduction system consists of two processors (called the high-level and low-level stages)

connected in series to reduce noise by some 20 dB above 1kHz. The encoder circuit is outlined in Fig. 3-1, and the decoder circuit in Fig. 3-2.

##### • CT-20, CT-540, and CT-740

Type B Dolby NR is incorporated in the HA-11226 IC. Recording/playback switching is achieved by a switching IC (equivalent to HD-14066BP).

##### Recording Amplifier

A high-frequency peaking circuit has been incorporated with an operational amplifier IC (M5218L) in the recording amplifier, and the recording equalizer in an NFB loop.

The amplifier characteristics can be switched by the TAPE SELECT switch to match the characteristics of each type of tape.

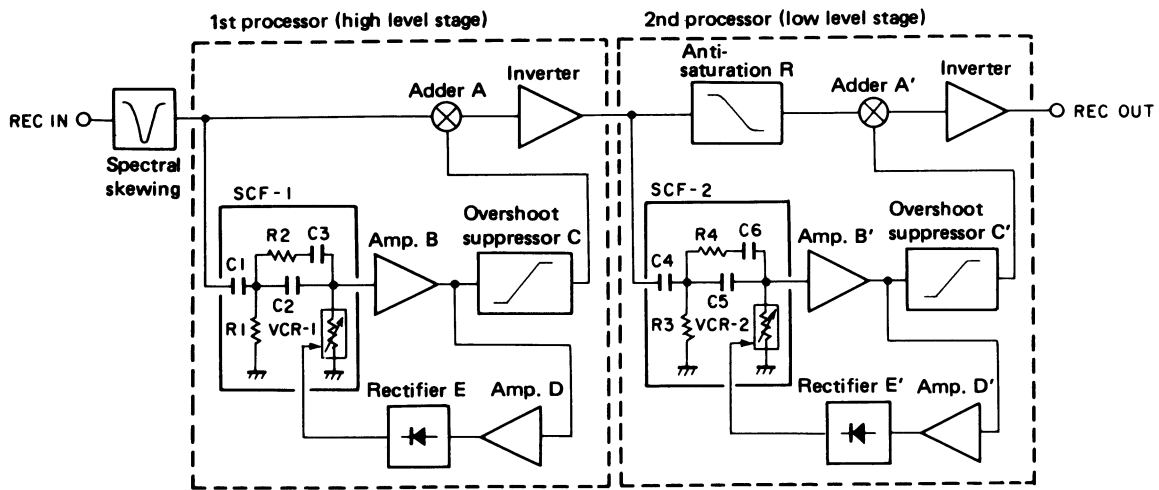

Fig. 3-1 Block diagram for encoding operation

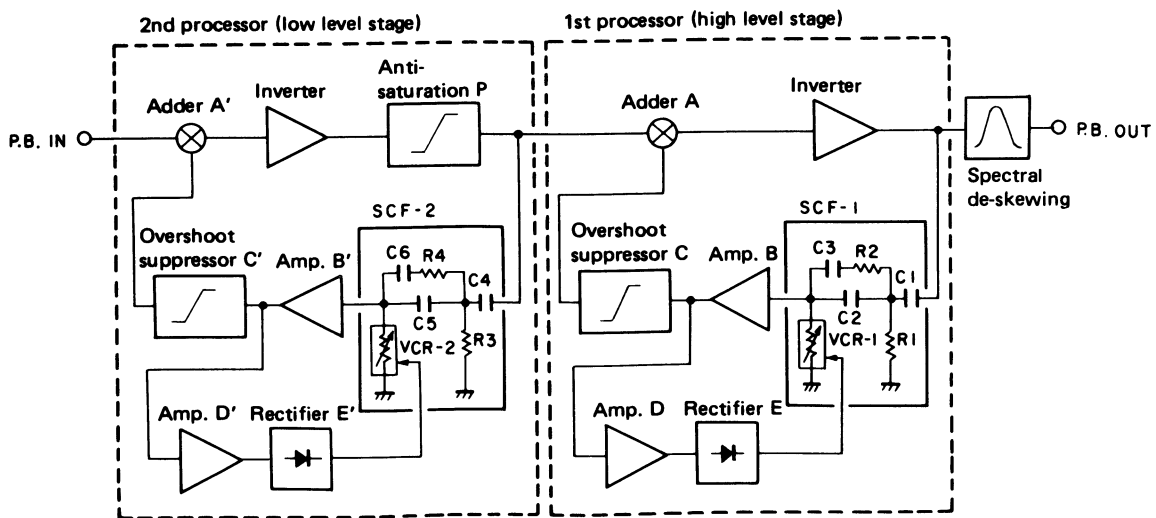

Fig. 3-2 Block diagram for decoding operation

**Bias Oscillator**

This is a push-pull generator controlled by the transistor switch in the emitter circuit of the oscillator transistor. Bias switching for different types of tapes involves changing the strength of the oscillation by changing the power line voltage in the oscillator circuit.

**3.2 CONTROL CIRCUITS**

The control system in this tape deck is based on a tape deck control IC (PD2006), major control operations involving non-lock feather-touch switch operations. This IC employs a digital counter system for setting of mechanism control timing, thereby ensuring accurate timing. The PD2006 pin functions are listed in Fig. 3-3, and the various control pin outputs and changes in timing during each mode are outlined in Figs. 3-4 thru 3-7.

Pin No.	Symbol	Input/Output	Function
1	GND	—	Ground.
2	CLOCK	—	External CR connection for built-in clock generator. f=12.8kHz setting.
3	CLEAR	Input	Cleared by "L". Due to built-in auto clear function, this pin can be left open (Note 1).
4	AR	Input	Anti-recording pin. Recording inhibited by "L". (Note 1).
5	REC	Input	REC KEY input. "L" active. (Notes 1 and 2).
6	PLAY	Input	PLAY KEY input. "L" active. (Note 1).
7	STOP	Input	STOP KEY input. "L" active. (Note 1).
8	REW	Input	REW KEY input. "L" active. (Note 1).
9	PAUSE	Input	PAUSE KEY input (cyclic input). (Notes 1 and 3).
10	FF	Input	FF KEY input. "L" active. (Note 1).
11	TIMER/START	Input	3-level input. Timer recording at "H", timer playback at "L", off when open. (Note 4).
12	MS	Input	MS ON (music search) when "L". (Note 1).
13	SENSING	Input	Tape end detector input. Stop mode activated if "L" level is maintained for 2 seconds. (Note 5).
14	MS ENABLE	Output	"H" output for CUE and REVIEW operations.
15	PB PULSE	Output	100ms "H" pulse output when switching from REC mode to another mode.
16	REC PULSE	Output	100ms "H" pulse output when REC mode is set.
17	REC-H	Output	"H" output during REC and REC-PAUSE modes. Used for recording/playback switching control.
18	PB-H	Output	"H" output when not in REC or REC-PAUSE mode. Used for recording/playback switching control.
19	BIAS	Output	"H" output during REC and REC-PAUSE modes. Used as bias oscillator control output.
20	PAUSE IND.	Output	PAUSE indicator output. "H" output during PAUSE, PLAY-PAUSE, and REC-PAUSE modes.
21	PLAY OUT	Output	PLAY indicator output, and reel motor supply voltage switching control output.
22	MS SOL.	Output	Plunger solenoid (MS) drive output, and FF, REW, CUE, and REVIEW mode "H" output.
23	HB SOL.	Output	Plunger solenoid (HB) drive output, and PLAY and REC mode "H" output.
24	RM.L	Output	Reel motor control output. "H" output during REW and REVIEW modes.
25	RM.R	Output	Reel motor control output. "H" output during FF, PLAY, REC, and CUE modes.
26	LINE MUTE	Output	Line muting control output. "H" output during PLAY, REC, and REC-PAUSE modes.
27	REC MUTE	Output	Recording mute control output. "H" output during REC mode.
28	VDD	—	+5V power supply pin.

Note 1. Built-in pull-up resistance.

Note 2. REC mode is activated only REC KEY is ON (when AR="H"). Pressing the REC KEY and PLAY KEY simultaneously results in stop mode.

Note 3. PAUSE mode is released by pressing the PAUSE KEY again, not by pressing the PLAY KEY.

Note 4. Four seconds after the power is switched on, REC mode is activated if the TIMER START pin is "H", PLAY mode if "L"; and STOP mode if open.

Note 5. Schmitt trigger input.

Fig. 3-3 PD2006 pin description

MS SW: OFF

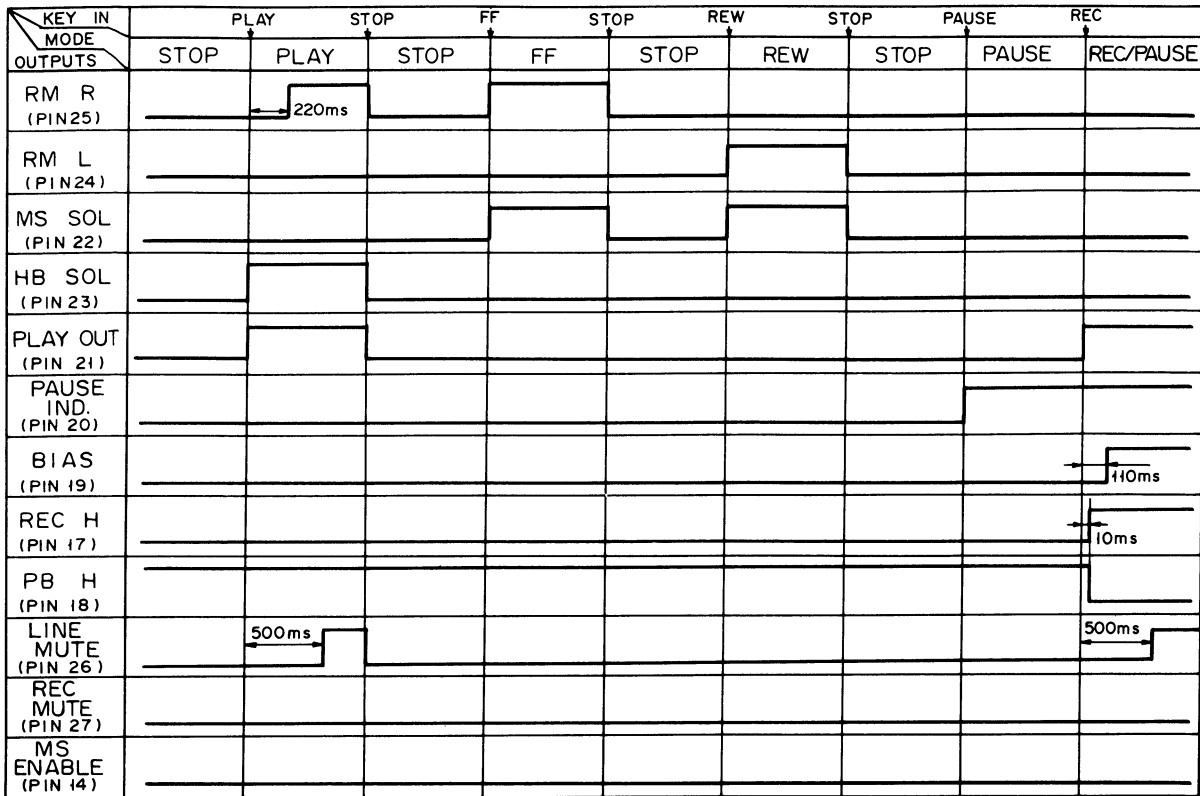

Fig. 3-4 PD2006 time chart (MS:OFF)

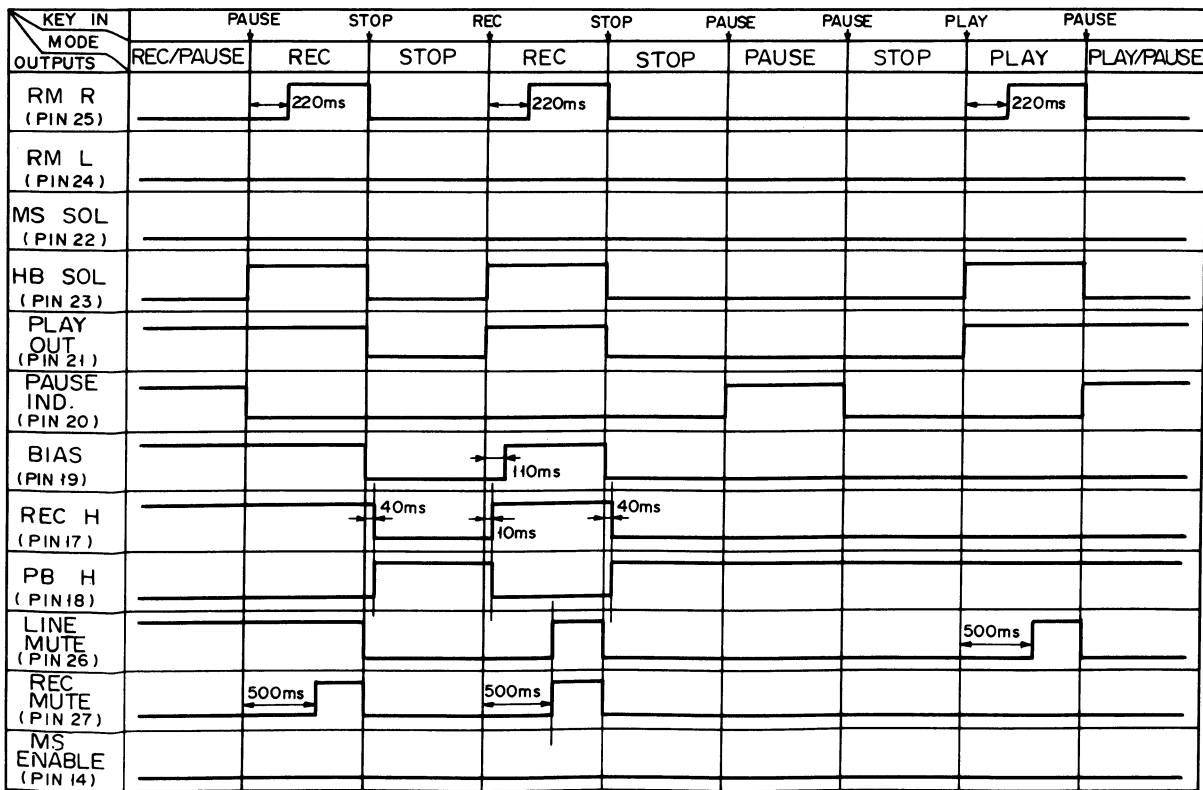

Fig. 3-5 PD2006 time chart (MS:OFF)

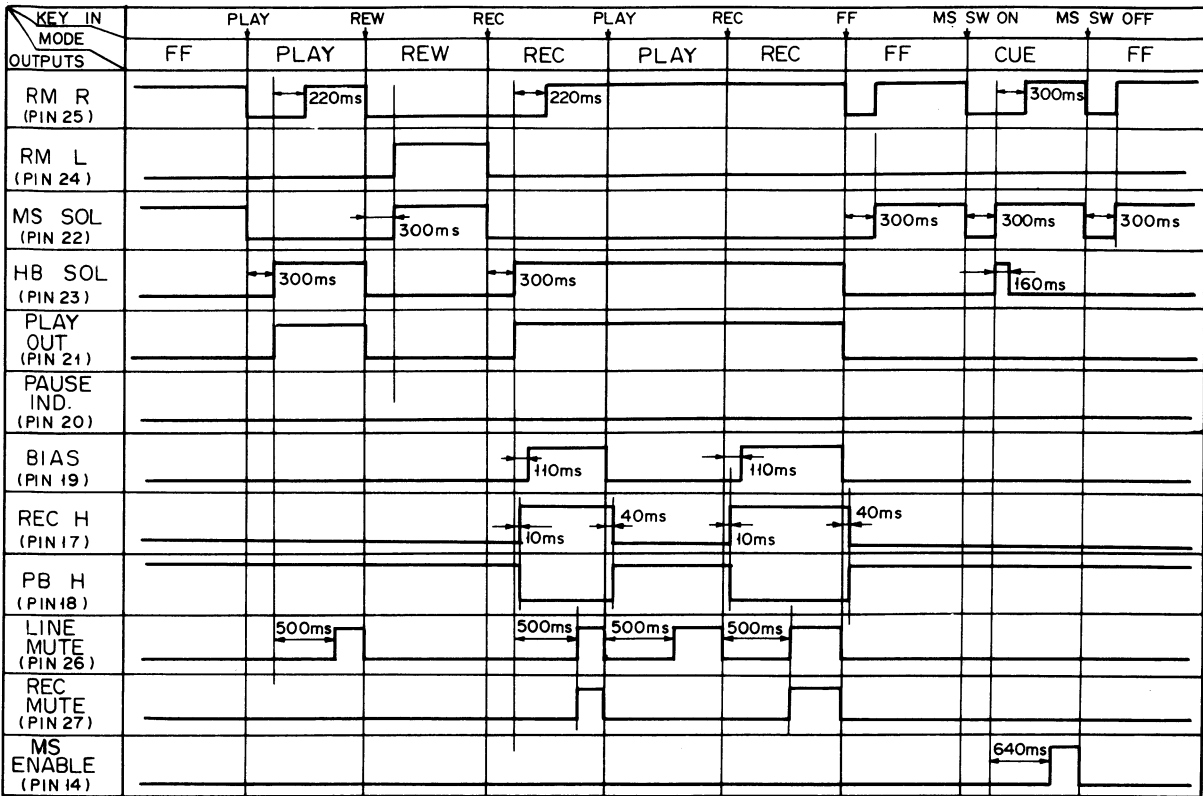

Fig. 3-6 PD2006 time chart (MS:OFF/ON)

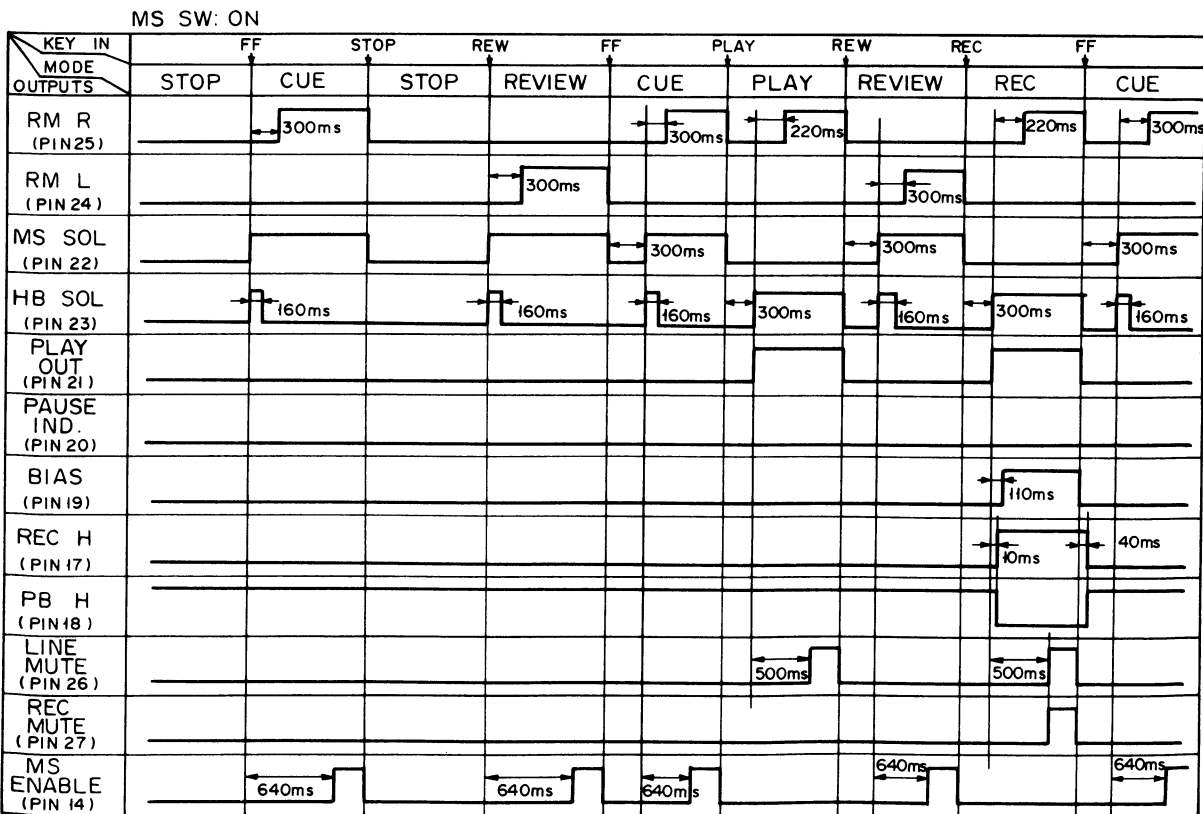
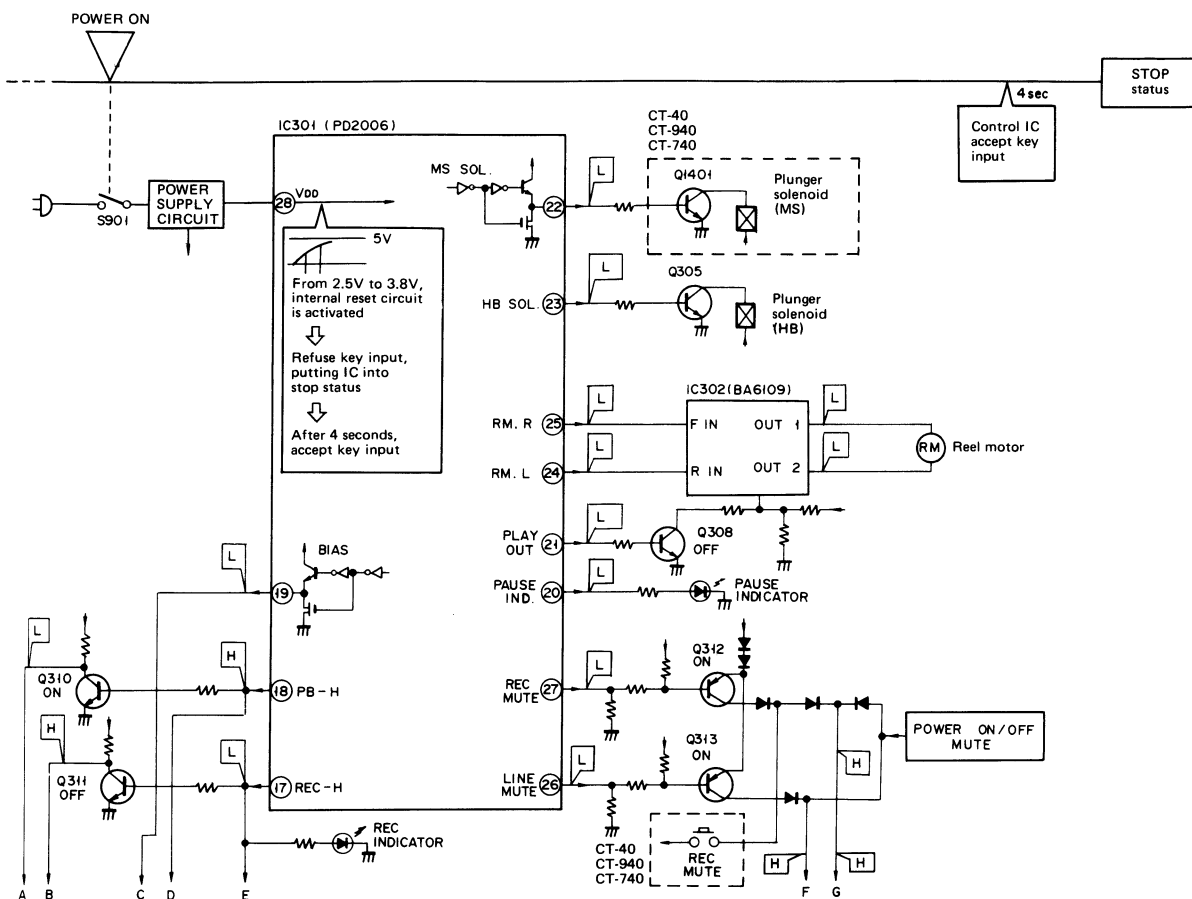
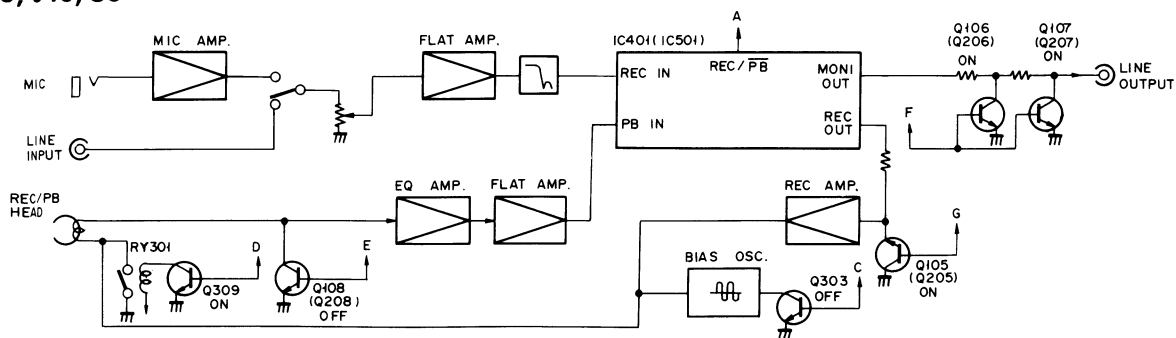

Fig. 3-7 PD2006 time chart (MS:ON)

POWER is ON



CT-40, 940, 30



CT-740, 20, 540

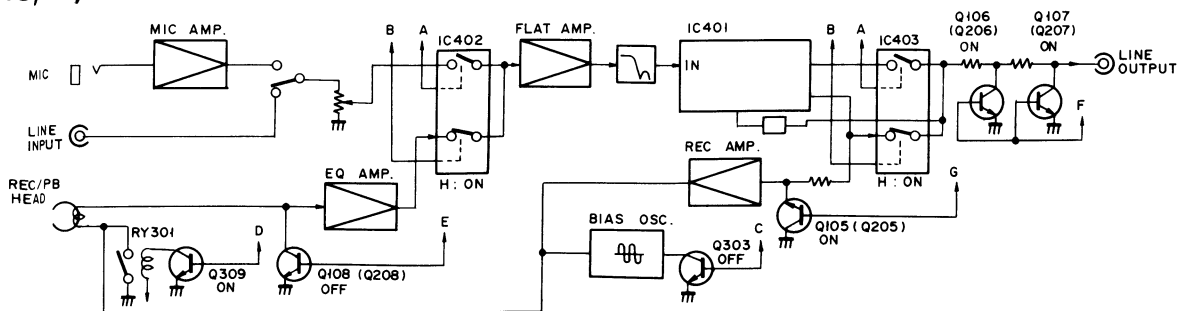
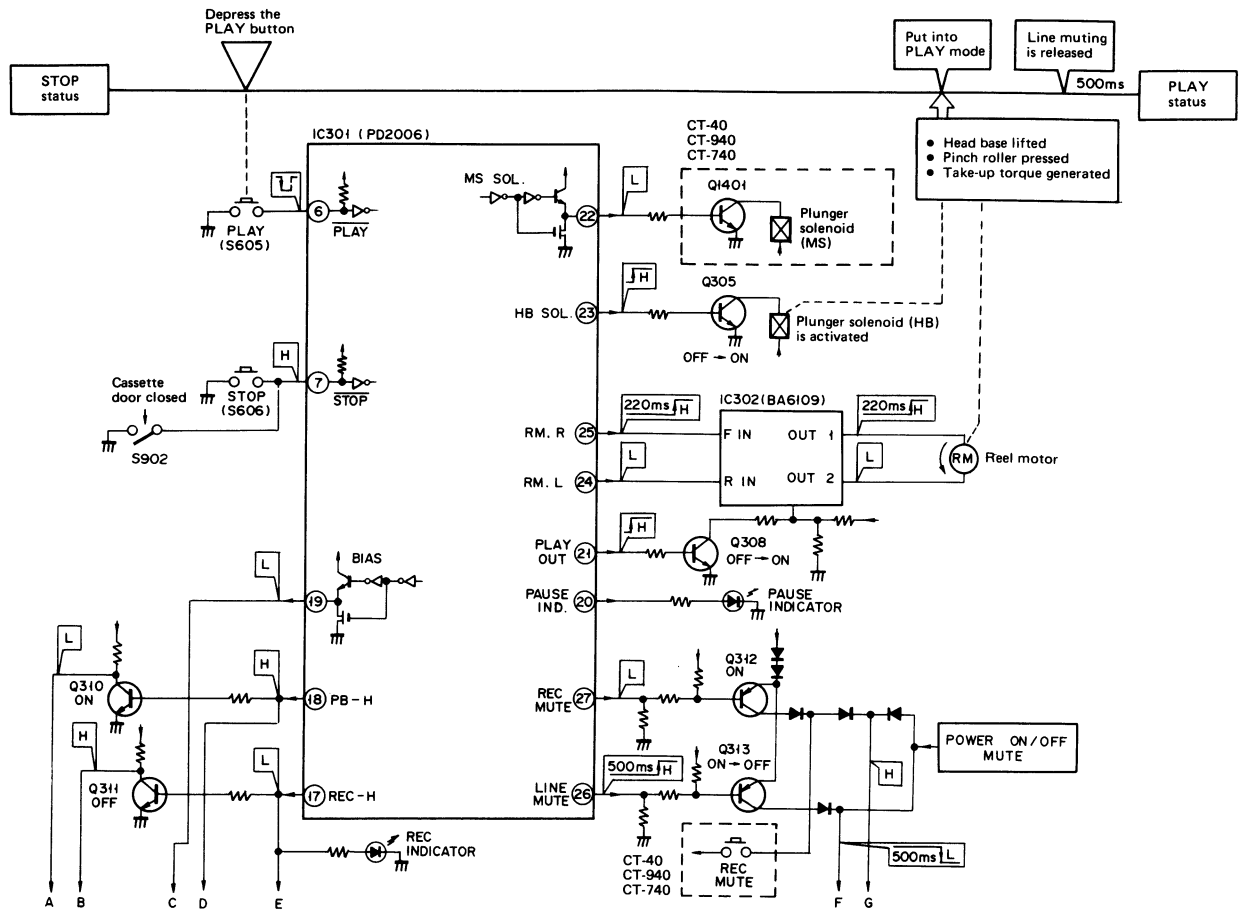

Fig. 3-8 Power ON



STOP to PLAYBACK



CT-40, 940, 30

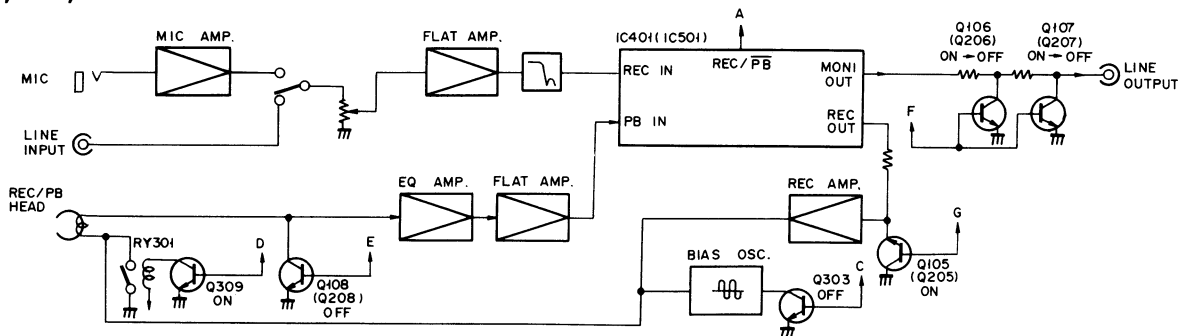

CT-740, 20, 540

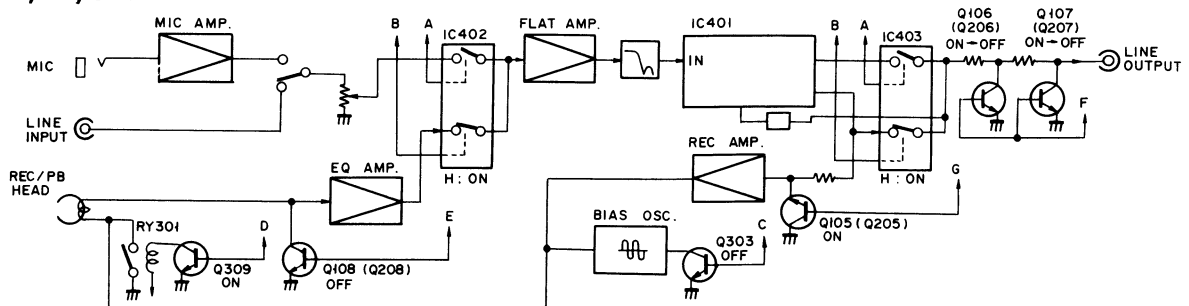

Fig. 3-9 Stop to playback



STOP to FF

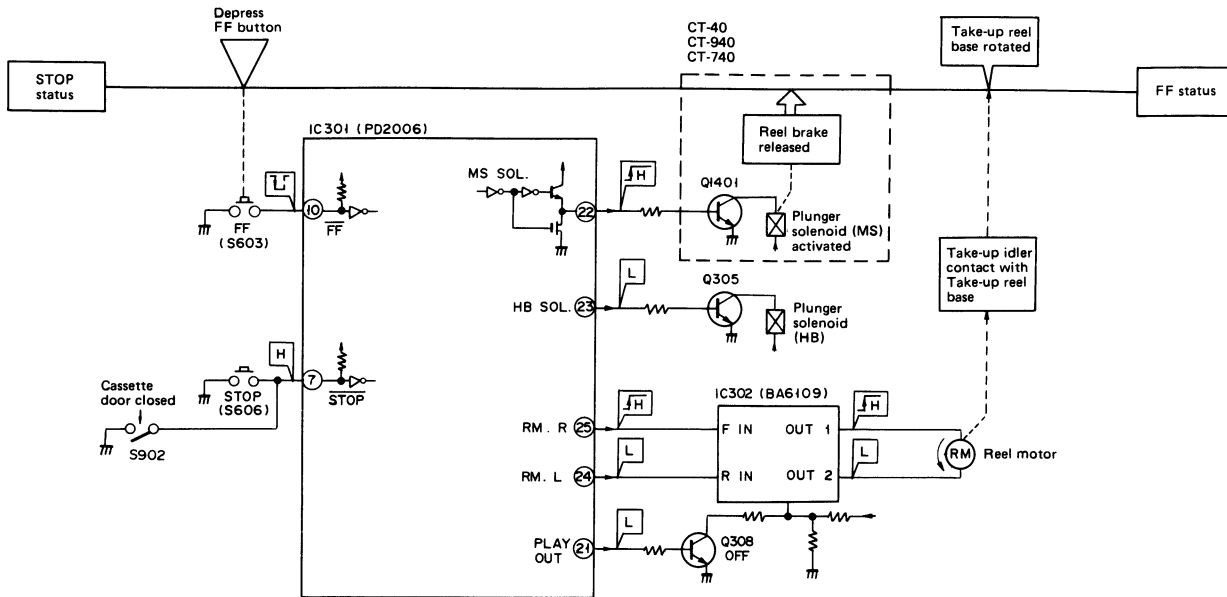

Fig. 3-11 Stop to FF

STOP to REW

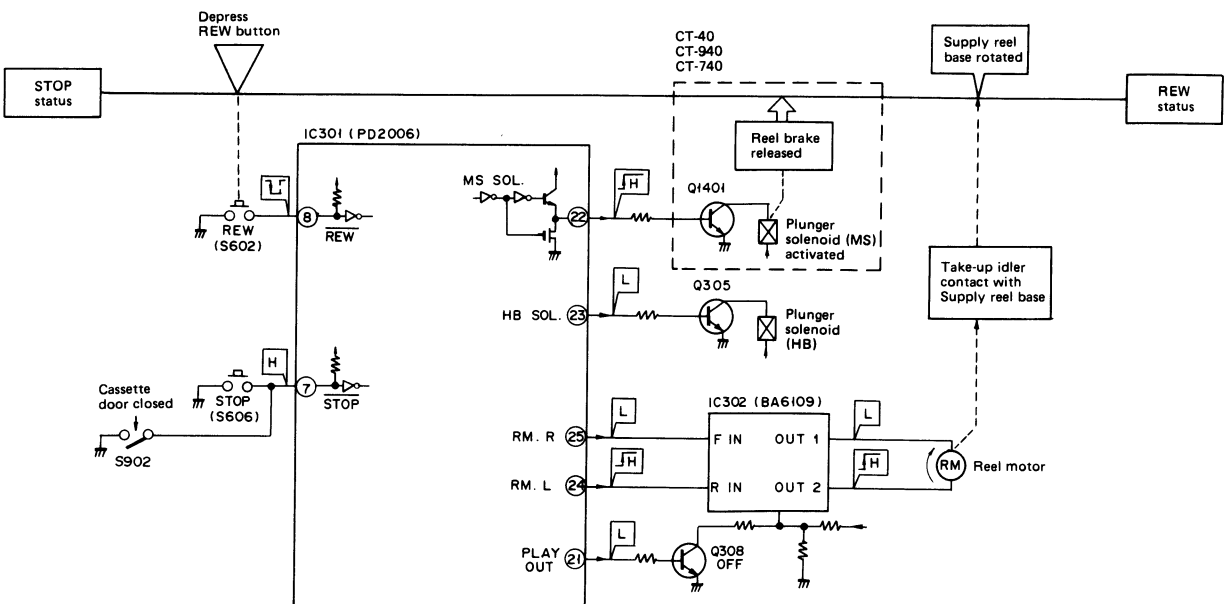

Fig. 3-12 Stop to REW

**Music Search (CT-40, CT-740, and CT-940)**

The music search function detects the beginning of specified recorded tunes, and can skip up to nine tunes during the search. The circuitry is centered in the music search assembly IC (IR-3R24). The number of skipped tunes is indicated in a yellow-green 7-segment LED numeric display (Fig. 3-13).

When the MUSIC SEARCH switch is OFF, the IR-3R24 RESET pin is at L level, and the Vcc2 supply is cut, thereby resetting the IC internal counter. Nothing appears in the display.

When the MUSIC SEARCH switch is ON, the RESET pin is opened, and the MS pin of IC301 (control IC) is switched to L level. And with the Vcc2 supply on, "0" is displayed as the skipped number of tunes. The number of tunes to be skipped is set by the MS SET switch. When the UP pin of IR-3R24 is switched to L level, the internal counter is counted up by one step by the trailing edge of the UP pin L level signal. (The display returns to "1" again after "9" is displayed). When the FF or REW button is pressed, the CUE or REVIEW operation is commenced, and the playback signal is applied to the PREAMP IN pin of

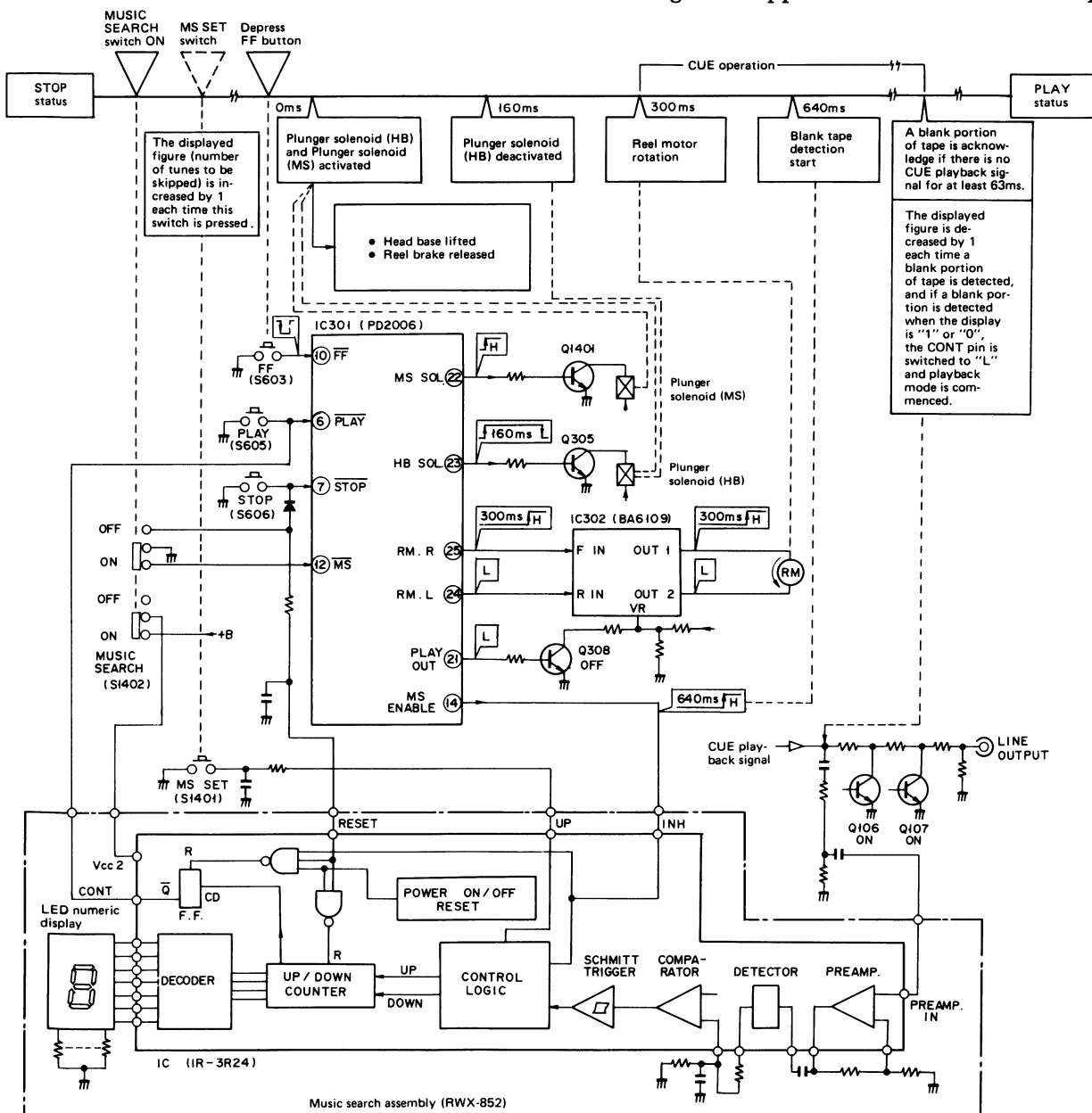

Fig. 3-13 Music search operation

IR-3R24. If the INH pin is at L level, the internal counter is prohibited from counting down. However, 640ms after the beginning of the CUE or REVIEW operation, the MS ENABLE pin of IC301 is switched to H level, resulting in the IR-3R24 INH pin also being switched to H to enable down-counting and the music search operation to commence. If the input signal applied to the PREAMP IN pin of IR-3R24 is delayed by more than 63ms, blank portion of tape is detected, and the internal counter is counted by one. If a blank portion of tape is detected when the display shows "1" or "0", the down count results in the CONT pin level being switched to L, followed by the IC301  $\overline{\text{PLAY}}$  pin level also being switched to L. The tape deck is thus switched to playback mode. If the STOP button is pressed, the RESET pin is switched to L level, the counter is reset, and "0" appears in the display.

**Auto-Stop Operation**

If the tape is stopped during a tape transport mode (playback, fast forward, rewind, recording), the tape deck is automatically switched to stop mode. (Fig. 3-14). Tape transport is monitored by a detector IC (IC701) employing Hall elements. While the tape is moving, a magnetic disc is belt-driven by reel base (R), resulting in IC701 generating pulse output signals. These pulse signals are applied to pin 13 of the control IC (IC301). This pin is a Schmitt trigger input where an internal counter is reset by "H" level inputs. Hence, this counter is continuously reset while the tape is moving. When the end of the tape is reached, or if the tape is stopped for any other reason, "H" level inputs are no longer applied to pin 13 of IC301. The internal counter consequently completes counting within about two seconds, and the control IC (IC301) switches the tape deck to stop mode.

**Timer Start Operation**

Load a cassette half with erasure prevention tabs intact (in which case S01 and S902 are switched off). Depending on whether pin 11 of control IC (IC301) is set to +Vcc, GND, or open, timer recording, timer playback, or stop (off) mode will be selected approximately four seconds after the power is switched on.

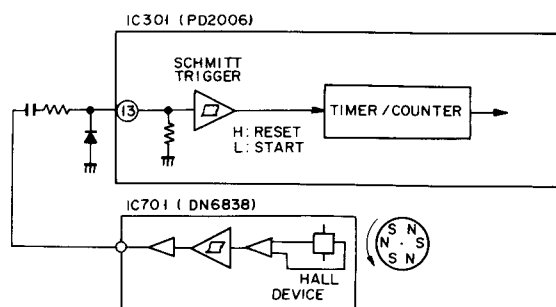

Fig. 3-14 Auto-stop operation

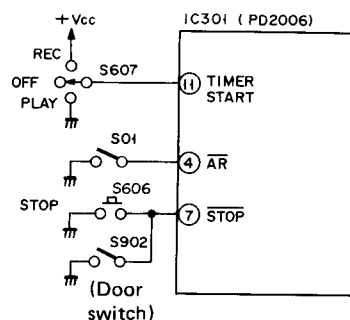

Fig. 3-15 Timer start operation

## 4. MECHANICAL OPERATIONS

### Head Base Shift Mechanism

In the CT-40/KU tape transport mechanism, capstan torque is used to lift the head base (where the recording/playback and erase heads are mounted) during playback mode.

- **When Stopping (Fig. 4-1)**

The head base shift mechanism during stop mode is outlined in Fig. 4-1. In this state, cam (C), stopper (F), and cam gear (B) combine to form a single unit. The flywheel is belt-driven by the capstan motor and rotates counterclockwise together with the capstan gear (G). The trigger spring applies clockwise torque to cam gear (B).

Since the plunger solenoid (HB) has not been activated, the return spring (D) forces the trigger lever (E) hook to engage the stopper (F), thereby preventing the cam gear (B) from rotating.

The head base shift pin (H) is attached to the head base, and thus moves together with the head base.

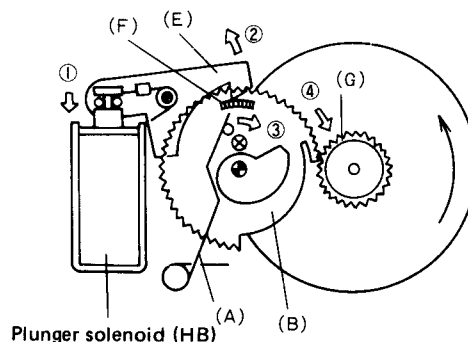

Fig. 4-2 STOP to PLAY operation 1

- **STOP → PLAY (Fig. 4-3)**

5. Gear (G) rotation is transmitted to gear (B).
6. Cam (C) lifts the shift pin (H).
7. Gear (B) is disengaged from gear (G) after the shift pin (H) reaches maximum height.

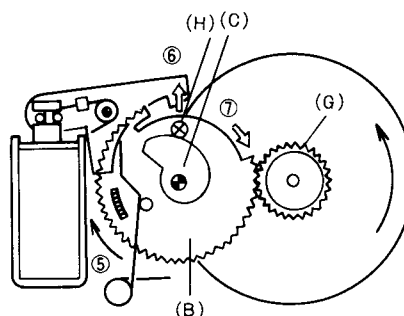

Fig. 4-3 STOP to PLAY operation 2

- **STOP → PLAY (Fig. 4-4)**

8. Although spring (A) would force gear (B) to continue rotating, it is stopped when stopper (F) meets arm (E). The shift pin (H) remains in the raised position (for playback mode). Since the shift pin (H) is attached to the head base, any shift pin movement results in head base movement. And lifting the head base presses the pinch roller against the capstan via the pinch roller pressure spring.

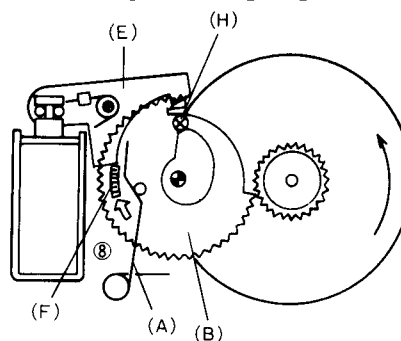

Fig. 4-4 STOP to PLAY operation 3

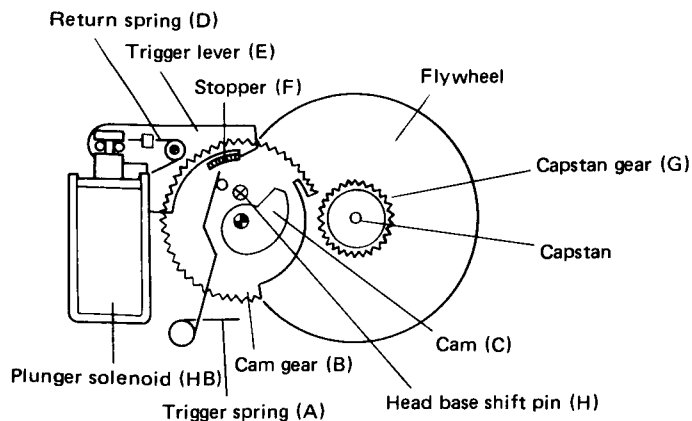

Fig. 4-1 Head base shift mechanism (STOP status)

- **STOP → PLAY (Fig. 4-2)**

1. The plunger solenoid (HB) is activated.
2. The lever (E) hook is disengaged from the stopper (F).
3. Spring (A) forces gear (B) to rotate.
4. Gear (B) engages gear (G).

● **Generation of tape take-up torque during playback mode (Fig. 4-5)**

The idler arm is moved towards the reel base (R) due to reaction to the counterclockwise reel motor rotation, resulting in the take-up idler making contact with the reel base (R), and the subsequent generation of take-up torque in that reel base.

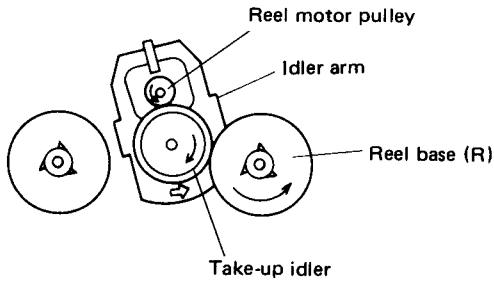

Fig. 4-5 Generation of take-up torque

● **PLAY → STOP (Fig. 4-6)**

9. The plunger solenoid (HB) is deactivated.
10. Spring (D) disengages lever (E) from stopper (F).
11. Gear (B) rotates due to spring (A).
12. The shift pin (H) is lowered by cam (C).
13. Stopper (F) is caught by the hook of lever (E), bringing the mechanism to the same stop state as shown in Fig. 4-1 (stop mode).

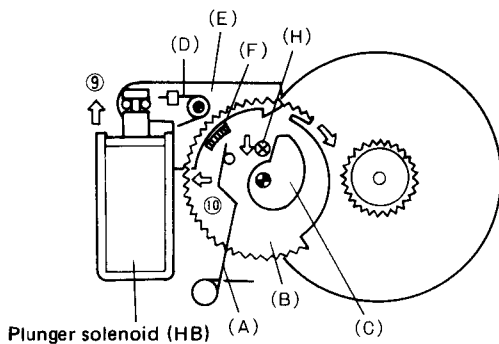

Fig. 4-6 PALY to STOP operation

**Fast Forward Operation**

● **When the music search function is involved (CT-40, CT-740, and CT-940)**

In Fig. 4-7, the plunger solenoid (MS) has been activated and the reel motor is rotating counterclockwise. As soon as this solenoid is activated, the brake lever moves to the left, thereby releasing brake R and brake L. Due to the reaction to the counterclockwise rotation of the reel motor, the idler arm moves towards reel base (R), and the take-up idler is pressed against reel base (R) which is thus rotated.

Note that the reel brake is released by lifting the head base shift pin during playback mode.

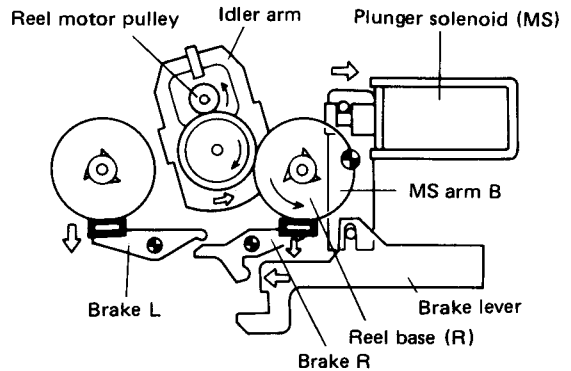

Fig. 4-7 Fast forward operation with MS mechanism

● **When the music search function is not involved (CT-20, CT-30, and CT-540)**

Without the MS solenoid and reel brake mechanisms, back-tension in the reel bases is obtained by constant application of a weak brake. The take-up idler is pressed against reel base (R) by the counterclockwise rotation of the reel motor, resulting in rotation of reel base (R) (Fig. 4-8).

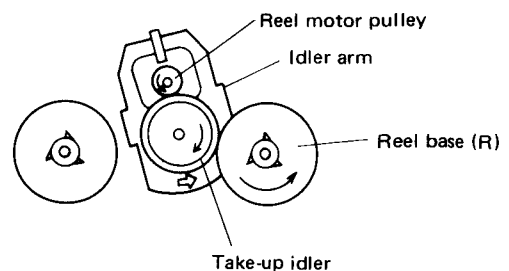

Fig. 4-8 Fast forward operation without MS mechanism

**Rewind Operation**

Apart from the reel motor rotation being reversed (clockwise) and reel base (L) being rotated (Fig. 4-9 or Fig. 4-10), rewind operation is the same as fast forward operation.

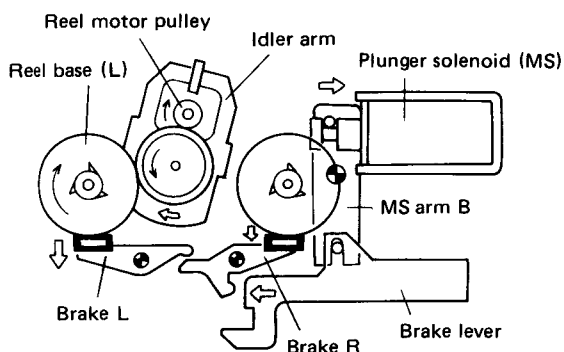

Fig. 4-9 Rewind operation with MS mechanism

**Music Search Operation (CT-40, CT-740, and CT-940)**

Designed to detect unrecorded portions of tape between recorded tunes, this function requires the recording/playback head to remain in contact with the tape during fast forward and rewind operations. That is, this feature is a variation of the cue and review feature.

First, the plunger solenoid (HB) is activated to switch the mechanism to playback mode as shown in Figs. 4-2 thru 4-4 (but only for a very short period of time). Plunger solenoid (MS) is activated at the same time, and although plunger solenoid (HB) is soon released, the head base is kept in the raised state by plunger solenoid (MS) via MS arm B, brake lever, and HB stopper. The pinch roller is separated from the capstan by MS arm A. When the reel motor then rotates, the cue (review) operation is started.

If the MS (Music Search) function is activated during fast forward or rewind mode, the tape transport is first stopped before commencing the MS operation.

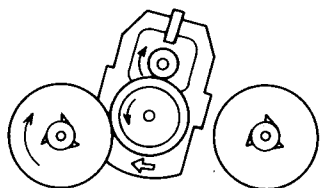
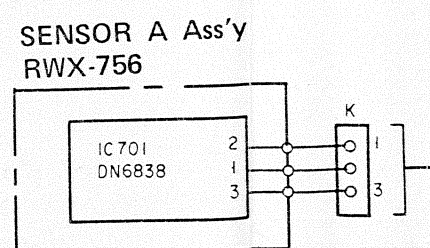
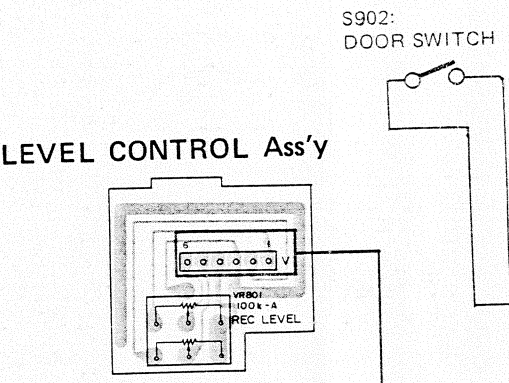
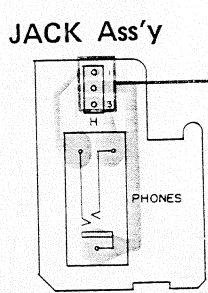
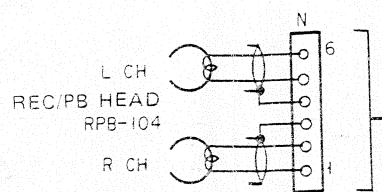
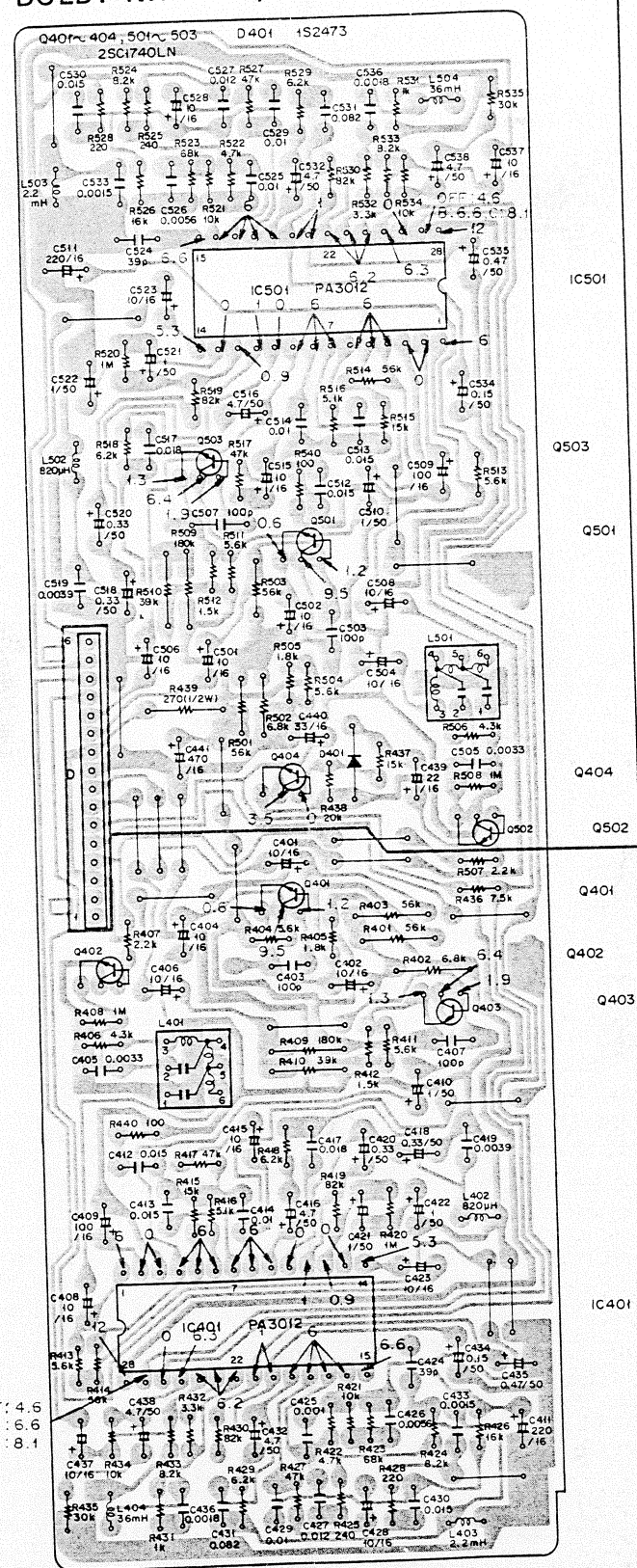

Fig. 4-10 Rewind operation without MS mechanism



# 6. P.C.BOARDS CONNECTION DIAGRAM

### DOLBY NR C Ass'y RWX-679



### MAIN Ass'y RWX-812

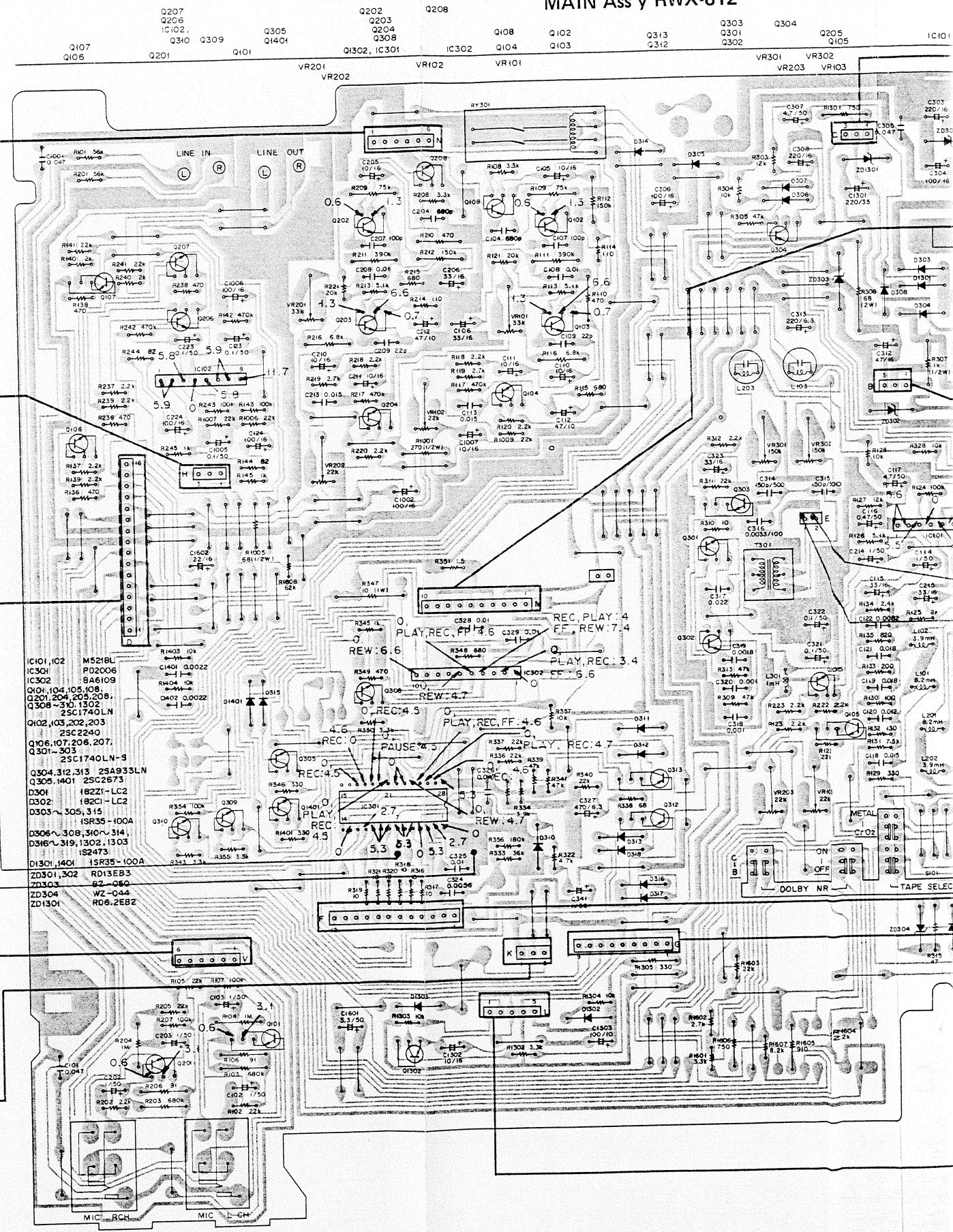

A  
B  
C  
D







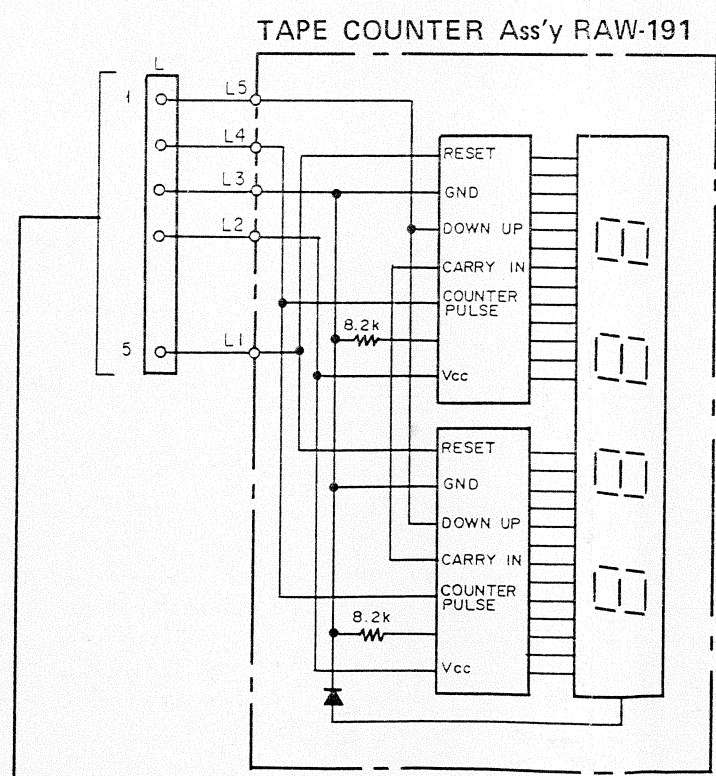
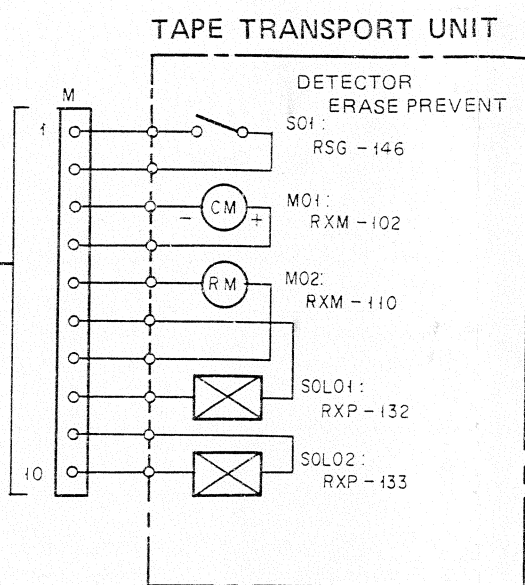
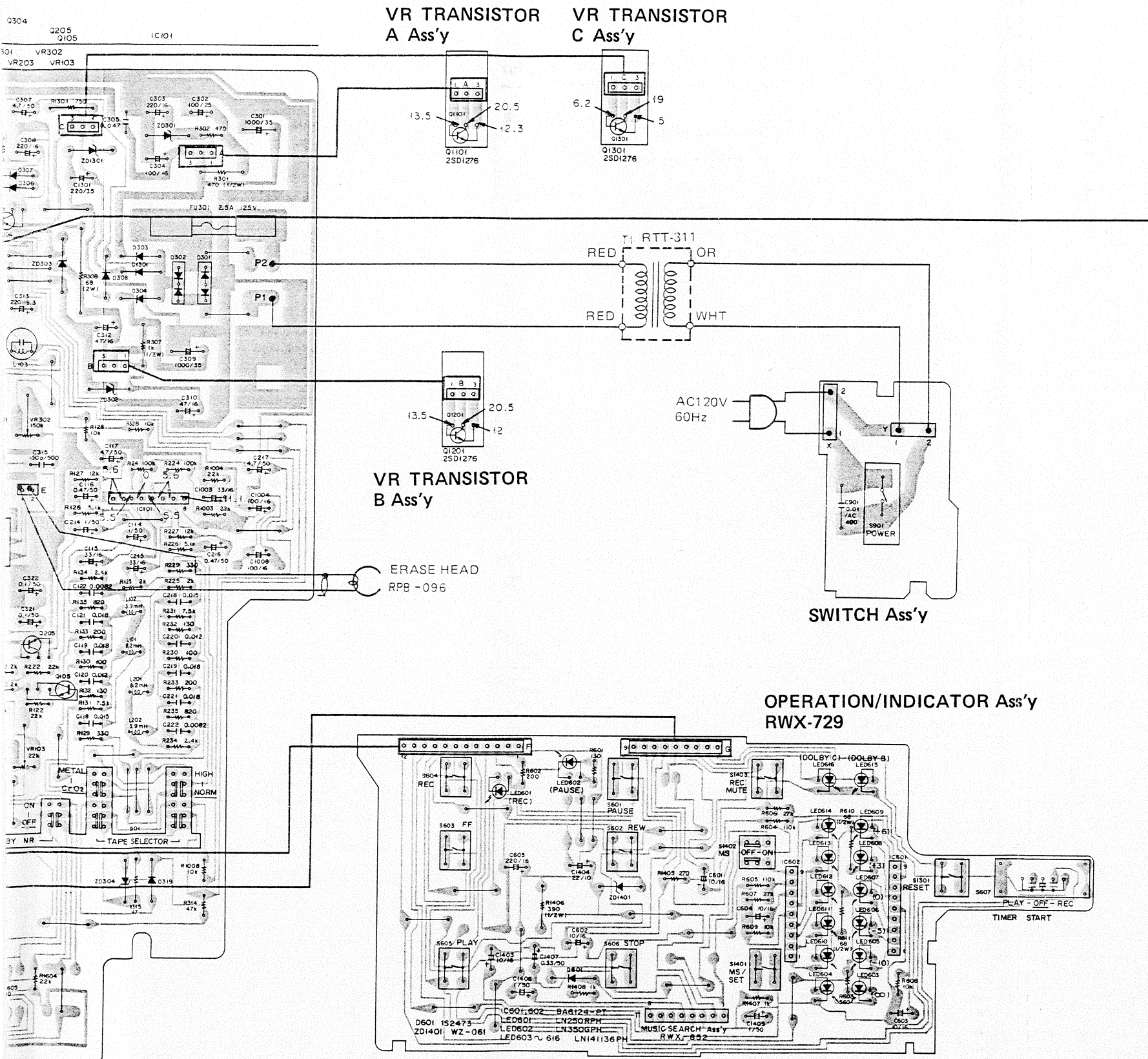

A

B

C

D

# 7. SCHEMATIC DIAGRAM

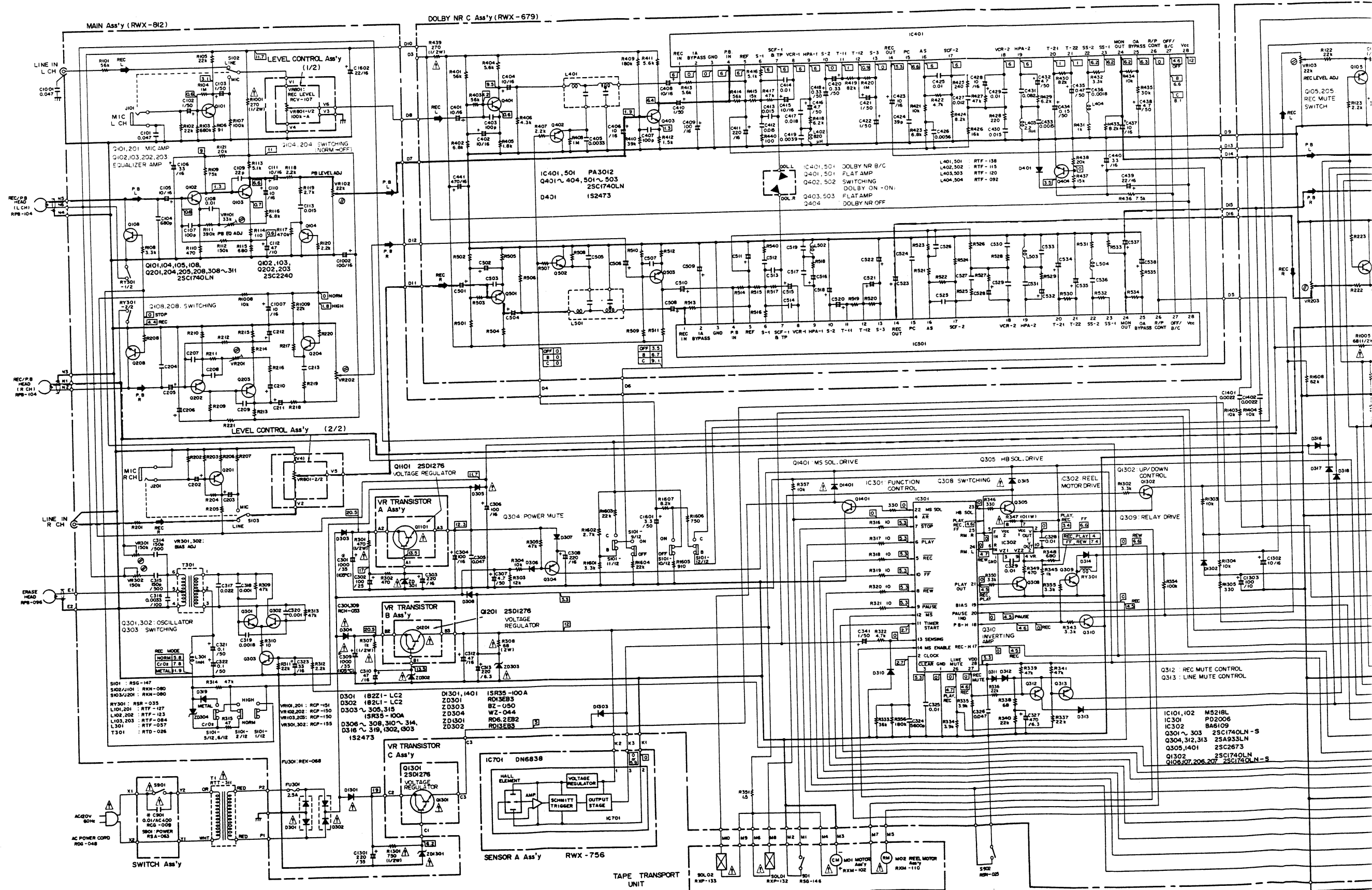

**NOTE:**  
The indicated semiconductors are representative ones only. Other alternative semiconductors may be used and are listed in the parts list.

- 1. RESISTORS:**  
Indicated in Ω, kΩ, MΩ, W, ±5% tolerance unless otherwise noted; kΩ, TAPE TRANSPORT UNIT  
M; MΩ, (F): ±1%, (G): ±2%, (K): ±10%, (M): ±20% tolerance
- 2. CAPACITORS:**  
Indicated in capacity (μF)/voltage (V) unless otherwise noted  
p; pF. Indication without voltage is 50V except electrolytic capacitor.
- 3. VOLTAGE**  
□: DC voltage (V) at no input signal
- 4. OTHERS:**  
→: Signal route.  
⊙: Adjusting point.  
⊠: The mark found on some component parts indicates the importance of the safety factor of the part. Therefore, when replacing, be sure to use parts of identical designation.  
\* marked capacitors and resistors have parts numbers.

**NOTE:**  
Playback signal route (Lch) ———  
Recording signal route (Rch) - - - - -

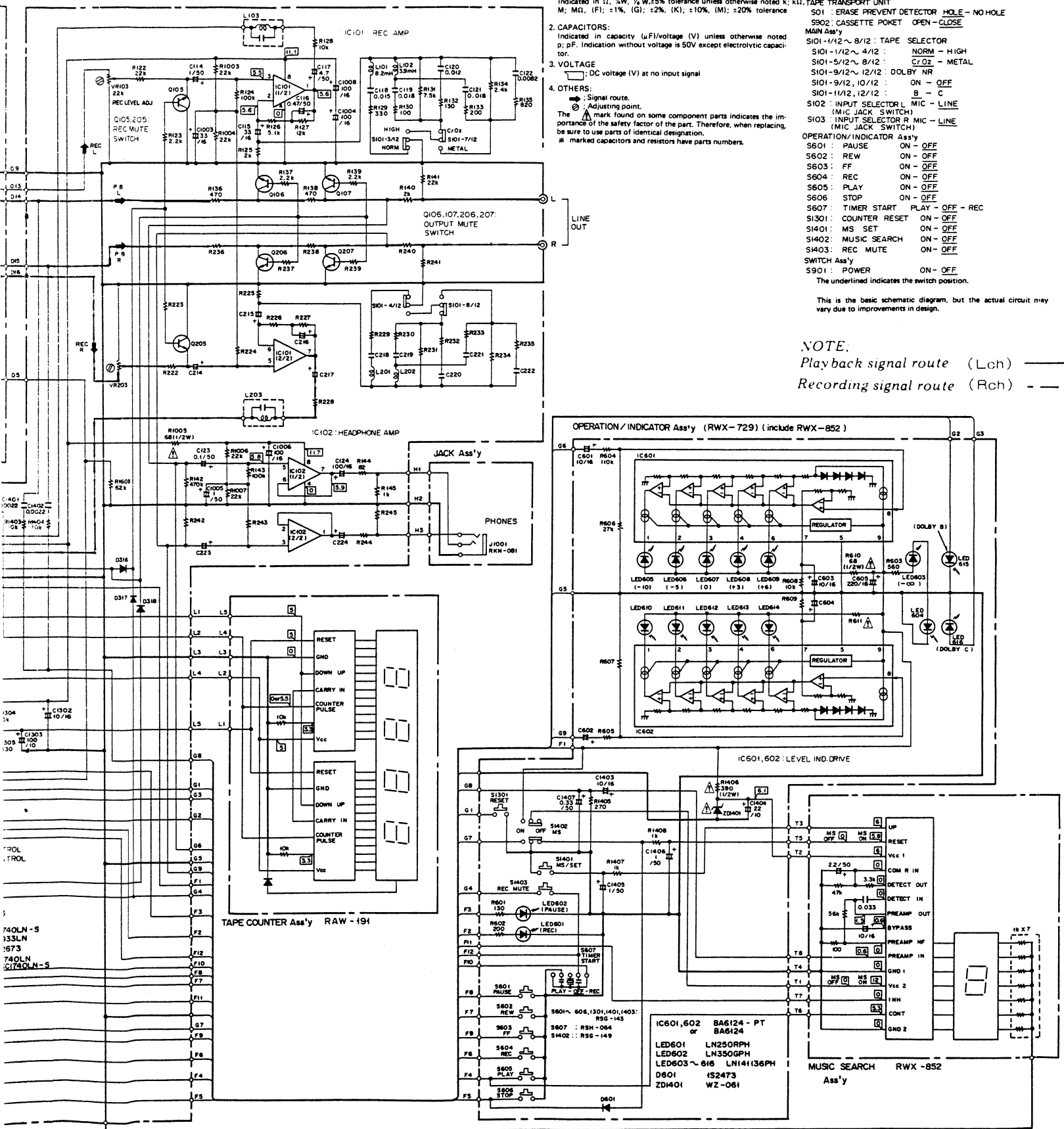

External Appearance of Transistors and ICs

M5218L

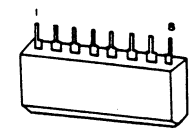

2SC2673

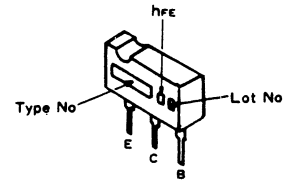

2SC1740LN  
2SA933LN

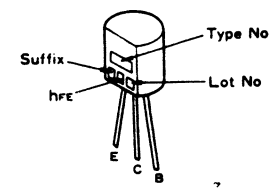

BA6124

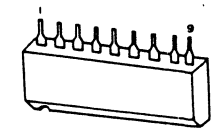

2SC2240

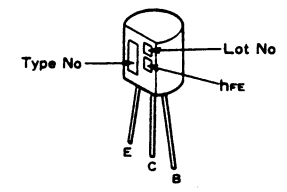

2SD1276

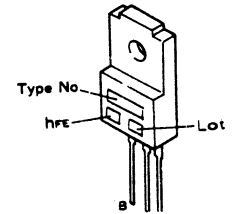

PD2006

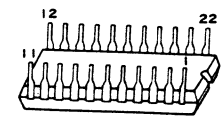

PA3012

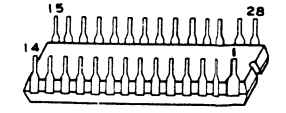

BA6109

