



MR 7083

AM/FM TUNER

McIntosh[®]

OWNERS MANUAL

IMPORTANT SAFETY INSTRUCTIONS

THESE INSTRUCTIONS ARE TO PROTECT YOU AND THE McINTOSH INSTRUMENT. BE SURE TO FAMILIARIZE YOURSELF WITH THEM.

1. Read all instructions - Read the safety and operating instructions before operating the instrument.
2. Retain Instructions - Retain the safety and operating instructions for future reference.
3. Heed warnings - Adhere to warnings and operating instructions.
4. Follow Instructions - Follow all operating and use instructions.
WARNING: TO REDUCE RISK OF FIRE OR ELECTRICAL SHOCK, DO NOT EXPOSE THIS INSTRUMENT TO RAIN OR MOISTURE.
5. Power Sources - Connect the power supply only to the type described in the operating instructions or as marked on the unit.
6. Power-Cord Protection - Route power-supply cords so that they are not likely to be walked on or pinched by items placed upon or against them, paying particular attention to cords at plugs, convenience receptacles, and the point where they exit from the instrument.
7. Ventilation - Locate the instrument for proper ventilation. For example, the instrument should not be placed on a bed, sofa, rug, or similar surface that may block ventilation openings; or, placed in a built-in installation, such as a bookcase or cabinet, that may impede the flow of air through the ventilation openings.
8. Heat - Locate the instrument away from heat sources such as radiators, heat registers, stoves, or other appliance (including amplifiers) that produce heat.
9. Wall or Cabinet Mounting - Mount the instrument in a wall or cabinet only as described in the owners manual.
10. Water and Moisture - Do not use the instrument near water - for example, near a bathtub, washbowl, kitchen sink, laundry tub, in a wet basement, or near a swimming pool, etc.
11. Cleaning - Clean the instrument by dusting with a dry cloth. Clean the panel with a cloth moistened with a window cleaner.
12. Object and Liquid Entry - Do not permit objects to fall and liquids to spill into the instrument through enclosure openings.
13. Nonuse Periods - Unplug the power cord from the AC power outlet when left unused for a long period of time.
14. Damage Requiring Service - Service must be performed by qualified service personnel when:
 - A. The power supply cord or the plug has been damaged; or
 - B. Objects have fallen, or liquid has been spilled into the instrument; or
 - C. The instrument has been exposed to rain; or
 - D. The instrument does not appear to operate normally or exhibits a marked change in performance; or
 - E. The instrument has been dropped, or the enclosure damaged.
15. Servicing - Do not attempt to service beyond that described in the operating instructions. All other service should be referred to qualified service personnel.
16. Grounding or Polarization - Do not defeat the inherent design features of the polarized plug. Non-polarized line cord adaptors will defeat the safety provided by the polarized AC plug.
17. **CAUTION: TO PREVENT ELECTRICAL SHOCK DO NOT USE THIS (POLARIZED) PLUG WITH AN EXTENSION CORD, RECEPTACLE OR OTHER OUTLET UNLESS THE BLADES CAN BE FULLY INSERTED TO PREVENT BLADE EXPOSURE.**

ATTENTION: POUR PREVENIR LES CHOCS ELECTRIQUES PAS UTILISER CETTE FICHE POLARISEE AVEC UN PROLONGATEUR, UNE PRISE DE COURANT OU UNE AUTRE SORTIE DE COURANT, SAUF SI LES LAMES PEUVENT ETRE INSEREES A FOND SANS EN LAISSER AUCUNE PARTIE A DECOUVERT.



The lightning flash with arrowhead, within an equilateral triangle, is intended to alert the user to the presence of uninsulated "dangerous voltage" within the product's enclosure that may be of sufficient magnitude to constitute a risk of electric shock to persons.



CAUTION: TO PREVENT THE RISK OF ELECTRIC SHOCK, DO NOT REMOVE COVER (OR BACK). NO USER-SERVICABLE PARTS INSIDE. REFER SERVICING TO QUALIFIED PERSONNEL.



The exclamation point within an equilateral triangle is intended to alert the user to the presence of important operating and maintenance (servicing) instructions in the literature accompanying the appliance.

The serial number, purchase date, and McIntosh Laboratory Service Contract number are important to you for possible insurance claim or future service. Record this information here.

Serial Number

PurchaseDate

Service Contract Number

Upon application, McIntosh Laboratory provides a Service Contract to the original purchaser. Your McIntosh Authorized Service Agency can expedite repairs when you provide the Service Contract with the instrument for repair.



Contents

INTRODUCTION	3
INSTALLATION	4, 5
HOW TO CONNECT	6, 7
CONNECTING DIAGRAM	8
FRONT PANEL CONTROLS	9, 10
PERFORMANCE LIMITS	11
PERFORMANCE CHARTS	12
TECHNICAL DESCRIPTION	13, 14
BLOCK DIAGRAM	15

Your MR 7083 AM/FM Digital Tuner will give you many years of satisfactory performance. If you have any questions, please contact,

CUSTOMER SERVICE
McIntosh Laboratory Inc.
2 Chambers Street
Binghamton, New York 13903-9990
Phone: 607-723-3512

**Take Advantage of 3 Years of
Contract Service. . .
Fill in the Application NOW.**

McINTOSH THREE YEAR SERVICE CONTRACT

An application for A THREE YEAR SERVICE CONTRACT is included with this manual.

The terms of the contract are:

1. If the instrument covered by this contract becomes defective, McIntosh will provide all parts, materials, and labor needed to return the measured performance of the instrument to the original performance limits free of any charge. The service contract does not cover any shipping costs to and from the authorized service agency or the factory.
2. Any McIntosh authorized service agency will repair all McIntosh instruments at normal service rates. To receive the free service under the terms of the service contract, the service contract certificate must accompany the instrument when taken to the service agency.
3. Always have service done by a McIntosh authorized service agency. *If the instrument is*

modified or damaged as a result of unauthorized repair the service contract will be cancelled.

Damage by improper use or mishandling is not covered by the service contract.

4. The service contract is issued to you as the original purchaser. To protect you from misrepresentation this contract cannot be transferred to a second owner.
5. Units in operation outside the United States and Canada are not covered by the McIntosh Factory Service Contract, irrespective of the place of purchase. Nor are units acquired outside the USA and Canada, the purchasers of which should consult with their dealer to ascertain what, if any, service contract or warranty may be available locally.

The McIntosh MR 7083 is a high quality AM/FM Tuner whose design has been governed by insistence on high performance with long life, great flexibility and sensitivity.

You will derive the greatest enjoyment and most satisfaction from your MR 7083 when you understand its operations and functions. Your time invested now will return added value to you because you will get the best results from your MR 7083.

McIntosh has earned world renown for its technological contributions for improved sound. When you bought McIntosh, you bought not only high technology, you bought technological integrity proven by time. The McIntosh MR 7083 Tuner is continuing evidence of McIntosh technological superiority and integrity.

Music reproducing instruments that carry the McIntosh name have always been designed for technological leadership and to maintain the McIntosh reputation for durability, long life, and best sound. McIntosh has had to earn the foremost reputation for quality performance. McIntosh has provided user-oriented facilities and appearance, and McIntosh design provides for ease of maintenance or repair. These fundamental elements are incorporated in the McIntosh MR 7083 AM/FM Tuner, the easiest to operate yet with extensive useful features.

Your McIntosh MR 7083, above all others, will deliver the best sound and the greatest ease of use with a high degree of flexibility.

Some of the features that set the MR 7083 apart from the ordinary are:

The advanced AM/FM tuner design of the MR 7083 displays the station frequencies digitally. Stations are selected easily in any one of these ways: A. use the manual tuning knob, B. use the SCAN up or down touchbuttons, C. use the preset station touchbuttons or, D. use the SEARCH which will preview the preset stations for 5 seconds each.

The sound enhancing SPATIAL audio processor provides an aural picture that is more "stereo like" in quality and dimension. On noisy, weak FM stations or AM stations, SPATIAL provides reduced noise and retains a broad stereo-like sound.

High quality tape recordings of FM broadcasts can be made without the interference that stereo transmissions can cause. Carefully designed suppression circuits eliminate the potential for stereo carrier noise when making "off the air" tape recordings.

A unique Phase Locked Loop Multiplex decoder

delivers STEREO FM with lower distortion, lower noise, and better separation.

The most useful and flexible AM antenna system will suit your particular installation. A low-impedance loopstick will, in most local areas, provide AM signals while rejecting noise and interference. In noisy AM locations, an external noise reducing, noise canceling, shielded loop will provide ideal input signal. In a remote location, a conventional 'long wire' antenna can be used.

The MR 7083 can be remote controlled from a McIntosh IR Remote Control system.

All in all, your selection of the MR 7083 will be reinforced by your day-to-day use of this superb instrument. Good listening.

The trouble-free life of an electronic instrument is greatly extended by providing sufficient ventilation to prevent the build-up of high internal temperatures that cause deterioration. Allow enough clearance so that cool air can enter at the bottom of the cabinet and be vented from the top. With adequate ventilation the instrument can be mounted in any position. The recommended minimum space for installation is 15 inches (38.1 cm) deep, 17 inches (43.2 cm) wide, and 6 inches (15.2 cm) high.

The MR 7083 may be installed in a McIntosh cabinet or custom installed in furniture of your choice. Always provide adequate ventilation. Never place it above heat generating components such as high powered amplifiers. Provide 1½ inches (3 cm) of space above the preamplifier so as not to interfere with a cooling air flow.

CUSTOM INSTALLATION

The PANLOC system of installing equipment conveniently and securely is a product of McIntosh research. The PANLOC buttons on the front panel will lock the unit firmly in place when they are turned approximately one quarter turn clockwise. A counterclockwise turn of the PANLOC buttons unlocks the chassis from its mounting.

To install the instrument in a McIntosh cabinet, follow the instructions that are enclosed with the cabinet. For any other type of installation, follow these instructions:

1. Unpack from Carton

Open the carton and remove the PANLOC brackets,

hardware package, and mounting template. Remove the instrument from its plastic bag and place it upside down on the shipping pallet. Unscrew the four plastic feet from the bottom of the chassis.

2. Mark the Cabinet Panel

Tape the mounting template in position on the cabinet panel where the instrument is to be installed. The broken lines that represent the outline of the rectangular cutout also represent the outside dimensions of the chassis. Make sure these lines clear shelves, partitions, or any equipment. With the template in place, first mark the six A and B holes and the four small holes that locate the corners of the cutout. Then, join the four corner markings with pencil lines, using the edge of the template as a straightedge.

3. Drill Holes

Use a drill with a 3/16 inch (5 mm) bit held perpendicular to the panel and drill the six A and B holes. Then, using a drill bit slightly larger than the tip of your saw blade, drill one hole at each of two diagonally opposite corners. The holes should barely touch the inside edge of the penciled outline. Before taking the next step, make sure that the six A and B holes have been drilled.

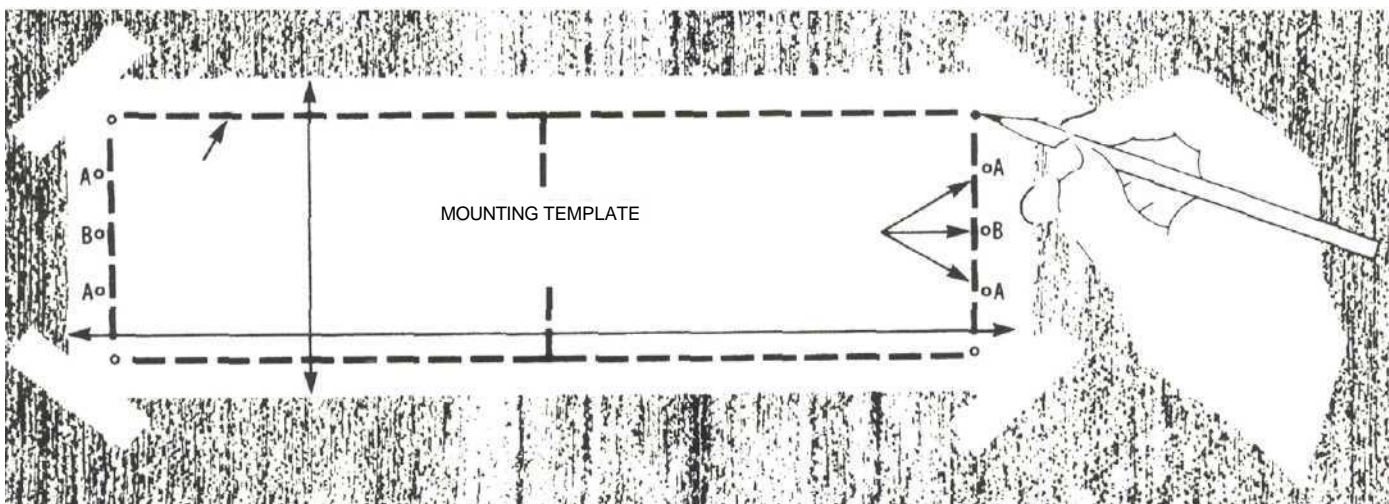

4 INSTALLATION

4. Saw the Panel Cutout

Saw carefully on the inside of the penciled lines. First make the two long cuts and then the two short cuts. After the rectangular opening has been cut out, use a file to square the corners and smooth any irregularities in the cut edges.

5. Install the Mounting Strips

In the hardware package are two mounting strips, and two 1-1/4" (31.8mm) black long screws that have a flat head. Use these screws, one on each end, to fasten the mounting strips. They are attached through the center hole, marked B on the template. Make sure the screw heads are drawn flush or slightly into the wood before attaching the Panloc brackets.

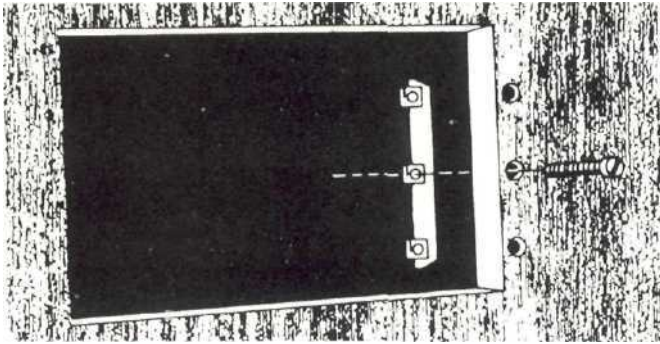

6. Attach the PANLOC Brackets

In the hardware package are two sets of screws. For panels less than 1/2" (12.7mm) thick, use the 3/4" (19.1mm) long screws; for thicker panels, use the 1-1/4" (31.8mm) long screws.

Using two screws of the proper length in the A holes on each side, attach the PANLOC brackets to the cabinet panel; the short flange is mounted against the front (face) of the cabinet panel. The screws pass through the PANLOC bracket flange, the cabinet panel, and then through the mounting strips previously mounted.

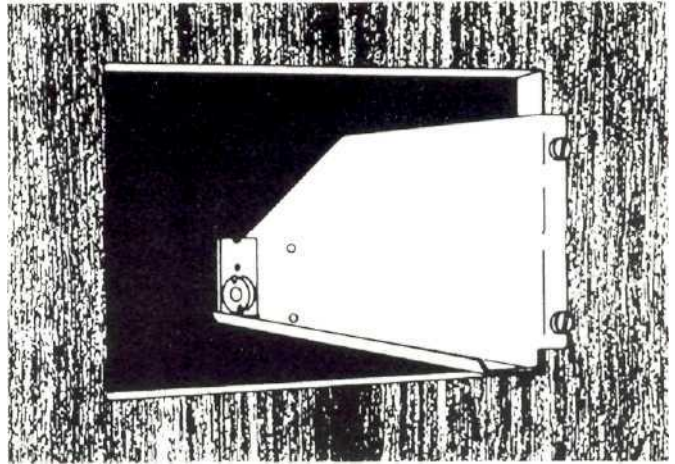

7. Install the Instrument

Guide the AC power cord through the panel opening to the back of the cabinet; then, slide the instrument into the opening carefully so that the rails on the bottom of each side of the chassis engage the tracks on the mounting brackets. Continue to slide the instrument into the cabinet until the front panel is flush with the cabinet panel. Turn the PANLOC buttons at the lower left and right corners of the instrument panel clockwise to lock the unit firmly in the cabinet. Turn the PANLOC buttons counterclockwise to unlock the instrument. It can then slide outward to permit the removal.

Fold out the photographs on the inside of the back cover. They will assist you in connecting the MR 7083 to your system. The numbers on the photographs refer to the paragraphs that follow.

The back panel of the MR 7083 has connectors labeled AUDIO OUTPUT, REMOTE CONTROL, AM antenna, 75 OHM FM antenna, SCOPE OUT, and AC power used to interconnect with associated equipment and the AC power line. Use shielded cables to connect the output signal to a preamplifier or power amplifier. To minimize the possibility of hum, the shielded cables should be of parallel construction or loosely twisted together and located away from the speaker connecting cables and AC power cords. Be certain to use good quality shielded cables for all interconnections. Your dealer can advise you on the kind and length of cables that will best suit your installation.

1. AUDIO OUTPUT

Use the FIXED AUDIO OUTPUT jacks on the rear panel to feed program to equipment which has its own volume control. The output level is a nominal 1.2 volt for 100% FM modulation. The low output impedance permits long audio cables to be used without a loss of high frequencies due to cable capacity.

2. VARIABLE OUTPUT

The VARIABLE OUTPUT jacks are used when you wish to adjust the tuner output level to match other program sources. The low output impedance permits long audio cables to be used without a loss of high frequencies due to cable capacity. The output level is easily adjusted by turning the output level screw with a screwdriver.

3. REMOTE CONTROL

The REMOTE CONTROL connector is designed for use with the McIntosh infrared remote control systems. With these systems, you can, from a hand-held remote control, turn on the tuner and the system, select from eight preprogrammed stations on either FM or AM, search sequentially the programmed stations on FM or AM and scan the entire FM or AM band.

4. AM ANTenna

Adjust the AM loopstick for best AM reception. Do not leave it positioned against the back panel. To do so will reduce the signal reception.

In noisy AM locations, we recommend that an

external shielded loop antenna be used. A shielded loop antenna is made from a length of single conductor shielded wire; microphone cable, coaxial cable, etc., arranged in a single turn loop. For best reception, orient the loop vertically. It may be attached around the frame of a window behind a curtain, on the back of the equipment cabinet, or in some similar way. Signal strength is proportional to the size of the loop; the larger the loop, the greater the received signal.

To prepare the antenna from the shielded cable, strip $\frac{3}{4}$ of an inch of outer insulation from each of the cable ends. From one end, completely remove the exposed $\frac{3}{4}$ " of shielding. Then remove $\frac{3}{8}$ of an inch of insulation from the center conductor.



Insert the exposed center conductor into the AM ANT push connector. Make sure the cut off shield does not come in contact with anything. On the other end, leave the shield intact and strip $\frac{1}{2}$ of an inch of insulation from the center conductor. On this end only, twist the exposed center conductor and the shield together.



Insert the twisted shield and center conductor into the ground (GND) push connector.

5. FM ANTenna

The antenna input impedance is 75 ohms designed to be fed by coaxial antenna cable. The input connector is a "Type F" which mates with cable company feed lines and coaxial cable. Interference rejection and low signal loss are among the benefits of coaxial cable.

Any one of four different FM antenna systems can be used with your MR 7083. 1) an outdoor FM antenna, 2) an all-channel (UHF-VHF-FM) antenna, 3) a cable input from your local cable company, or 4) the indoor dipole supplied.

A 75-ohm outdoor antenna designed for FM reception is recommended for optimum performance in all areas. In fringe areas, best

6 HOW TO CONNECT

results will be obtained with a highly directional FM antenna used with a rotator. Adjust the position of the antenna until the best reception is obtained.

A 75-ohm matched dipole antenna supplied with your MR 7083 may be used in urban or in high signal strength areas. The flexibility of the thin wire assembly permits it to be placed under a rug, tacked behind the stereo, or placed in any other convenient location. In some cases, it may be necessary to position the antenna for best signal reception. Avoid locating this antenna next to other wires or metal objects. An indoor antenna may not prove effective in houses having metal siding or metal insulation.

Although a 75-ohm coaxial feedline offers the best noise and multipath rejection, many antennas use 300-ohm twin lead. In this case, use a matching transformer (balun) to convert a 300-ohm antenna to the 75-ohm input impedance of the tuner.

6. SCOPE OUTPUT

The Horizontal output is the FM detector output and provides frequency deviation output for FM reception. The Vertical output is from amplitude detectors and provides signal strength output for both FM and AM. An oscilloscope may be connected for viewing FM multipath, signal strength, and other waveforms.

7. AC POWER

Plug the AC power cord into a 120 volt 50/60 Hz wall outlet. The plug blades are polarized so be certain the plug is fully inserted in the outlet to prevent blade exposure.

CAUTION: TO PREVENT ELECTRIC SHOCK, DO NOT USE THE (POLARIZED) PLUG ON THIS UNIT WITH AN EXTENSION CORD, RECEPTACLE, OR OTHER OUTLET UNLESS THE BLADES CAN BE FULLY INSERTED TO PREVENT BLADE EXPOSURE.

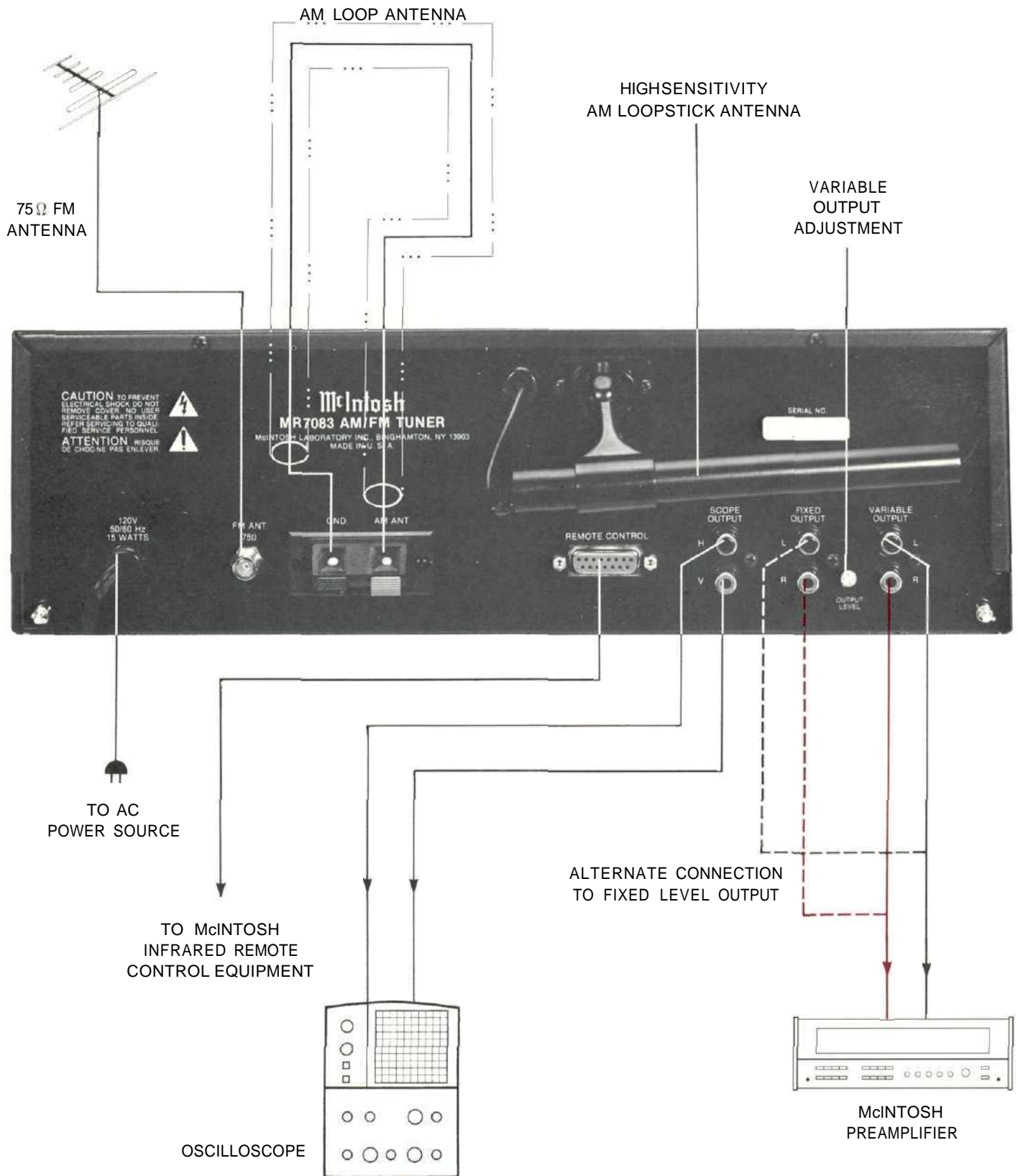

8 CONNECTING DIAGRAM

Fold out the photographs on the inside of the back cover. They will assist you in connecting the MR 7083 to your system. The numbers on the photographs refer to the paragraphs that follow.

Before operating your MR 7083 AM/FM Tuner, familiarize yourself with the controls and what they do. The lower half of the front panel is the operating control center. The field of 6 touchbuttons provides control of AC power, AM or FM, and audio processing for stereo, mono, or spatial operation. The 8 touchbutton field controls the 8 AM and 8 FM preset stations. The remaining 4 touchbuttons provide search, enter, and scan up and down. The knob is the manual tuning control.

The upper half of the front panel is the display area. It shows the operating status, digitally displays the station frequency and indicates precise tuning as well as station signal strength.

A. SIGNAL (STRENGTH) INDICATOR

The SIGNAL indicator is at the right of the station display area. The horizontal row of nine LED bar indicators, shows the relative strength of an FM or AM station being received. The greater the number of bars illuminated, the greater the received station's signal strength.

B. TUNING INDICATOR

Three LEDs ► ● ◀, two horizontal arrows and a center dot, located above the SIGNAL indicator, make up the TUNING indicator. A station is precisely center channel tuned when the center dot LED, only, illuminates.

All FM stereo broadcasts will cause the FM MPX bar indicator to illuminate. It is located to the left of the SIGNAL and TUNING indicators.

C. STATION FREQUENCY DISPLAY

The $\frac{3}{4}$ " high LED digital display of station frequency on both FM and AM provides a high degree of accuracy and is easy to read. The MR 7083 tunes and displays all FM frequencies 88.0 to 108.0 MHz and all AM frequencies 520 to 1710 kHz.

D. POWER ON

The red touchbutton turns the AC power on or off. When the power is turned on all indicators illuminate and the tuner returns to the last tuned station which has been retained in the tuner's electronic memory.

E. MONO

The MONO touchbutton switches the audio output of the tuner to MONO and lights the MONO indicator in the display area. When in FM and tuned to a stereo broadcast, the program will be heard as mono and the FM MPX indicator will be off.

F. SPATIAL

The SPATIAL touchbutton connects a McIntosh audio processor which influences both frequency distribution and phase relationships to provide enhanced special sound distribution. You will hear an enhanced sound in both AM and FM. It operates in both mono and stereo. When in SPATIAL the LED under the title illuminates.

G. STEREO

The STEREO touchbutton provides automatic, FM station activated, stereo/mono operation and lights the LED under the STEREO indicator in the display area.

H. AM

The AM touchbutton switches to the AM circuits of the tuner. The station display area will show the AM station frequency in kilohertz.

I. FM

The FM touchbutton switches to the FM circuits of the tuner. The station display area will show the FM station frequency in megahertz.

J. SEARCH

The SEARCH touchbutton causes the stations held in the memory for touchbuttons 1 thru 8 to be previewed for 5 seconds each. A second touch stops SEARCH.

K. PRESET STATION SELECTING TOUCHBUTTONS

A momentary press on one of the touchbuttons marked 1 thru 8 will recall from the electronic memory the preset FM or AM station assigned to that touchbutton. The corresponding green indicator above the numbered touchbutton will light.

L. ENTER

The ENTER touchbutton and any one of the eight momentary touchbuttons is used to insert a station into the electronic memory. Eight FM and eight AM stations can be preset.

To enter a station in the memory, tune to the

desired station with either the manual tuning knob or SCAN tuning. Press the ENTER touchbutton. Then, within 5 seconds, press a touchbutton, 1 through 8, and the station tuned will be recorded in the electronic memory.

The preset memory circuits are maintained by a special long life battery power supply. It will retain the instructions for years.

M. SCAN

Use the SCAN touchbuttons to automatically tune to the next station either up or down the selected broadcast band. The arrow beside the touchbutton indicates the direction of scan.

N. TUNING KNOB

Rotate the tuning knob until the correct frequency shows in the display area. Manual tuning is automatic when you turn the tuning knob.

A station is correctly tuned when only the center dot of the TUNING display lights. On each side of the center dot are horizontally display (▶ ◀) arrows. One of these will light as a station is approached to indicate tuning above or below the center frequency of the FM station. On AM, the TUNING display arrows are not lighted.

PERFORMANCE GUARANTEE

Performance Limits are the maximum deviation from perfection permitted for a McIntosh instrument. We promise you that your MR 7083 must be capable of performance at or exceeding these limits or you get your money back. McIntosh is the only manufacturer that makes this guarantee.

FM SECTION

USABLE SENSITIVITY

11.25dB which is 1.0 μ V across 75 ohms

50dB QUIETING SENSITIVITY

Mono—15dB which is 1.6 μ V across 75 ohms

Stereo—37dB which is 20 μ V across 75 ohms

SIGNAL TO NOISE RATIO

Mono—80dB

Stereo-75dB

FREQUENCY RESPONSE

Mono—+ 0, -1dB from 20 to 15,000Hz

Stereo-+0, - 1dB from 20 to 15,000Hz

HARMONIC DISTORTION

Mono- 0.08% at 100Hz

0.08% at 1000Hz

0.12% at 10,000Hz

Stereo- 0.08% at 100Hz

0.08% at 1000Hz

0.12% at 10,000Hz*

INTERMODULATION DISTORTION

Mono-0.08%

Stereo—0,12%

CAPTURE RATIO

1.5dB

ALTERNATE CHANNEL SELECTIVITY

70dB

SPURIOUS RESPONSE

100dB

IMAGE RESPONSE

80dB

STEREO SEPARATION

50dB

AM SECTION

SENSITIVITY

AM 20 μ V external antenna input
(50 ohm source input)

SIGNAL TO NOISE RATIO

50dB at 30% modulation

60dB at 100% modulation

HARMONIC DISTORTION

0.5% maximum at 30% modulation

FREQUENCY RESPONSE

50Hz to 6000Hz NRSC**

ADJACENT CHANNEL SELECTIVITY

45dB minimum IHF

IMAGE REJECTION

78dB minimum

GENERAL INFORMATION

AUDIO OUTPUT

Fixed: 1.2V RMS at 100% modulation

Variable: 1.2mV to 1.2V at 100% modulation

SEMICONDUCTOR COMPLEMENT

Transistors 37

Integrated Circuits 28

Varactors 8

LEDs 53

Diodes 74

POWER REQUIREMENT

120V 50/60Hz 10 watts

MECHANICAL INFORMATION

SIZE:

16-1/8 inches wide (40.6 cm) by 5-7/16 inches high (13.8 cm) by 13 inches deep (33 cm), from the mounting surface, including PANLOC shelf and back panel connectors. Knob clearance required is 1-1/4 inches (3.2 cm) in front of the mounting panel.

FINISH:

Front panel is glass with special gold/teal nomenclature illumination and black with gold anodized aluminum. Chassis is black.

MOUNTING:

Exclusive McIntosh developed professional PANLOC

WEIGHT:

15½ pounds (7.0 kg) net, 27½ pounds (12.5 kg) in shipping carton

*Spectrum analyzer required for measurement

**National Radio Systems Committee proposed spec, for AM tuners, Dec. '89

FM Performance at 98MHz
1 kHz Modulation

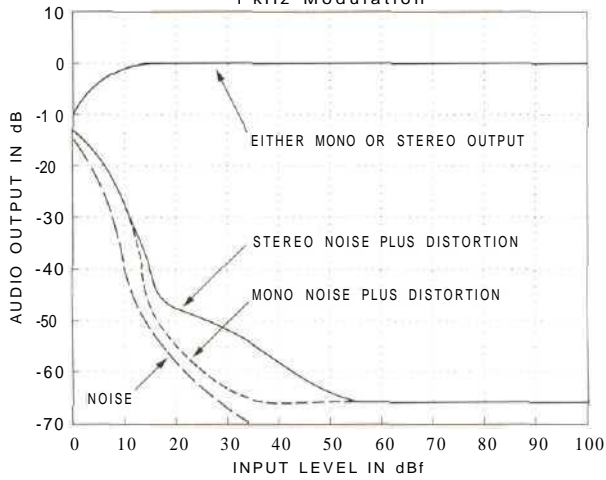

AM Performance at 1MHz
400Hz 30% Modulation

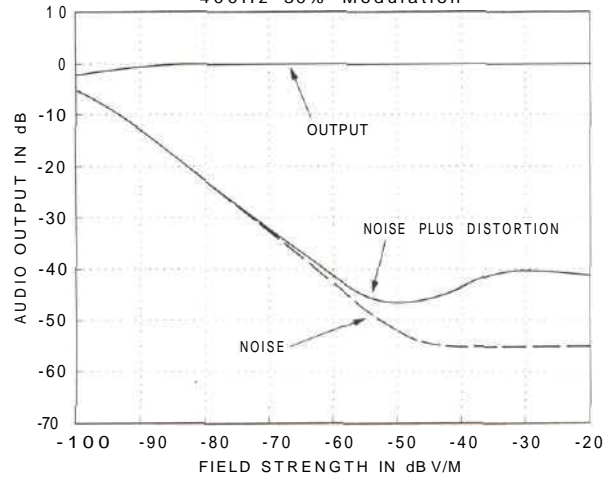

FM Frequency Response
and Stereo Separation

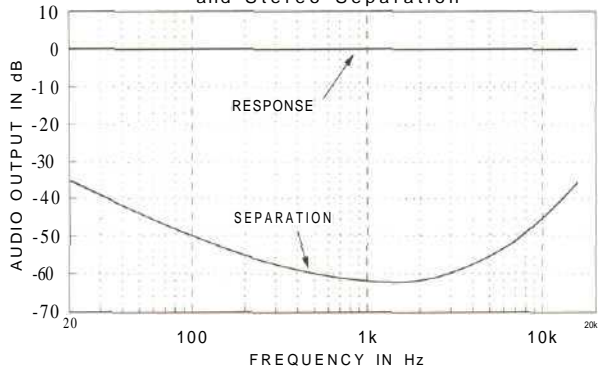

AM Frequency Response

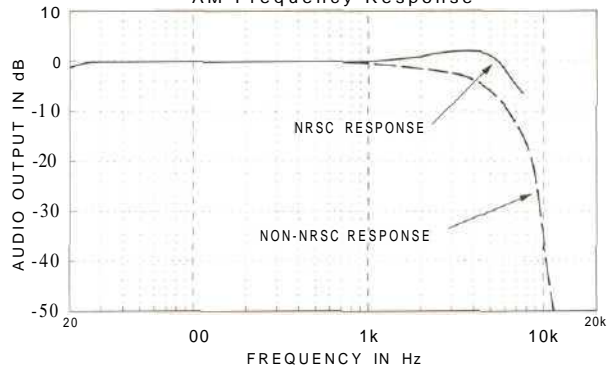

FM Selectivity

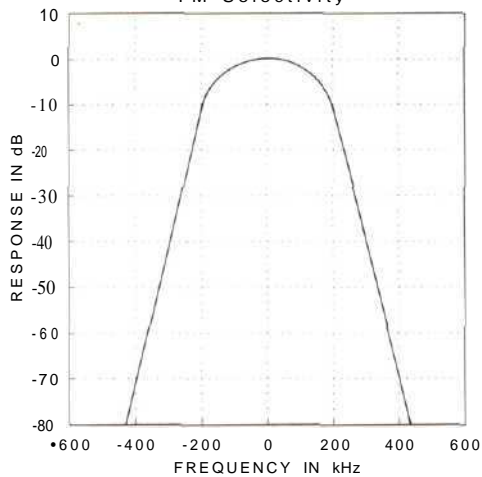

AM Selectivity

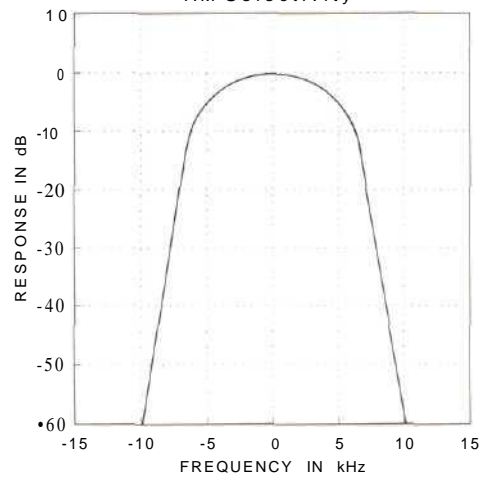

12 PERFORMANCE CHARTS

TUNING SYSTEM

The MR 7083 has three modes of tuning, MANUAL, SCAN, and PRESET.

In the MANUAL mode, two photo electric sensors sense the direction and degree that the tuning knob is rotated and move the tuned frequency accordingly. The smoothness and ease of tuning provided by this system is a result of only light coming in contact with small metal veins attached to the tuning shaft. Therefore, friction is almost non-existent and flywheel action is superior.

When a SCAN pushbutton is pressed, a ramped tuning voltage is generated, increasing in voltage for SCAN up, decaying for SCAN down. The ramp continues until the zero crossing of the detector's S curve is sensed at the input of the controller. It then stops and maintains that voltage with any necessary correction added.

Once a station has been tuned by either the MANUAL or SCAN mode, you may ENTER it into any of the eight memory locations. Simply press ENTER, then within 5 seconds, press the desired STATION button, 1 through 8. The station is then stored in the tuning controller's memory.

A momentary press of a preset STATION pushbutton will instantaneously recall the station from memory. A lithium battery maintains the memory for more than 10 years. Each time a pushbutton is pressed, a mute pulse suppresses any noise that might occur during the tuning process. During the scan mode, an output from the controller lowers the tuner sensitivity. This prevents weak noisy stations from being captured. If one wishes to listen to weak stations, they may tune them manually.

FM TUNER

A type F connector is provided on the rear panel for connection of a 75 ohm antenna or cable system.

Following the antenna matching circuit is an RF tuner of exceptional performance. It uses a DMOSFET RF amplifier, Double Balanced Mixer and 4 RF circuits that are tuned by matched varactor diodes. The results are high spurious rejection and great sensitivity. This circuitry and high tuning voltage eliminate RF intermodulation distortion caused by diode nonlinearities.

The FM IF section uses 2 transistors, 3 linear phase piezoelectric filters, and 2 integrated circuits. They combine to provide over 120dB of gain and a selectivity greater than 70dB. Limiting, muting, signal

strength drive, and FM detection are all functions of the last IF integrated circuit.

A phase locked loop (PLL) stereo decoder integrated circuit is the heart of the multiplex section. It has a high signal-to-noise ratio, low distortion, high channel separation, and high SCA rejection. The PLL MPX 1C eliminates inductors to minimize drift, provides integral lamp driving capability for stereo indication, and has transient free mono/stereo switching.

Following the PLL MPX decoder, an LC tuned dual notch filter (19 and 38kHz) is used to prevent tape recorder bias interference. The LC filter is driven from the MPX output amplifier and is terminated by an operational amplifier. This provides the necessary filter input and output impedances for proper phase response.

AM TUNER

The first element in the input section is a new Low Impedance Loopstick Antenna. It receives all the AM stations and rejects noise and other interference. A J FET-Transistor cascode amplifier follows. This amplifier provides excellent sensitivity and spurious response rejection. It also has a delayed AGC system that enhances the overload performance margin.

Two varactor tuned circuits and a double balanced mixer are next. This type of mixer has excellent image and IF rejection.

The mixer's 450kHz output feeds a matching transformer for the wide band linear phase piezoelectric 4 element lattice filter, then the IF amplifier, another transformer, and finally the AM detectors, filter and muting circuits.

Push terminals are provided for use with an external AM antenna. Due to the unusual design of the AM RF input section, almost any type of antenna can be used.

AUDIO PROCESSOR

The MR 7083 contains an audio processor that looks at L + R and L - R information and ENHANCES the sound by modifying the frequency and phase response.

If the tuner is in the MONO mode, and tuned to an AM or a weak FM station, it provides a stereo effect. Since this is done at audio frequencies, it does not degrade the signal-to-noise ratio. When receiving a strong FM station in stereo, it ENHANCES apparent separation giving a wider stereo image.

ANTENNA INPUTS

FM

The MR 7083 is provided with a 75 ohm coaxial antenna input. It is a standard "F" connector that mates with most common antenna and cable service feedlines. This type of input combines low loss with interference rejecting shielding.

A matched dipole antenna is provided for average reception. However, optimum performance is obtained with an outdoor highly directional beam antenna and rotator.

Although a 75 ohm coaxial feedline offers the best noise and multipath rejection, many antennas use 300 ohm twinlead. If this is the case, a matching transformer (balun) can be used.

AM

The AM antenna input on the MR 7083 is unusual in that it will accept almost any type of antenna. In a location of moderate signal strength and little interference (few fluorescent lights, motors, TV sets, etc.), the new Low Impedance Loopstick will give good performance. In a rural area, an outdoor long-wire might be desirable. However, the best over-all performance in a weak signal area can be obtained by using a shielded loop antenna.

The shielded loop is a bi-directional antenna. Its maximum signal pickup occurs when the station lies in the same plane as the loop. Minimum signal is perpendicular to the loop. This characteristic can be used to advantage by arranging the loop so that an unwanted signal, noise or interfering station, is in the pickup null.

REMOTE CONTROL

A 15 pin subminiature D connector is provided on the rear panel for interfacing the MR 7083 with McIntosh IR remote control systems.

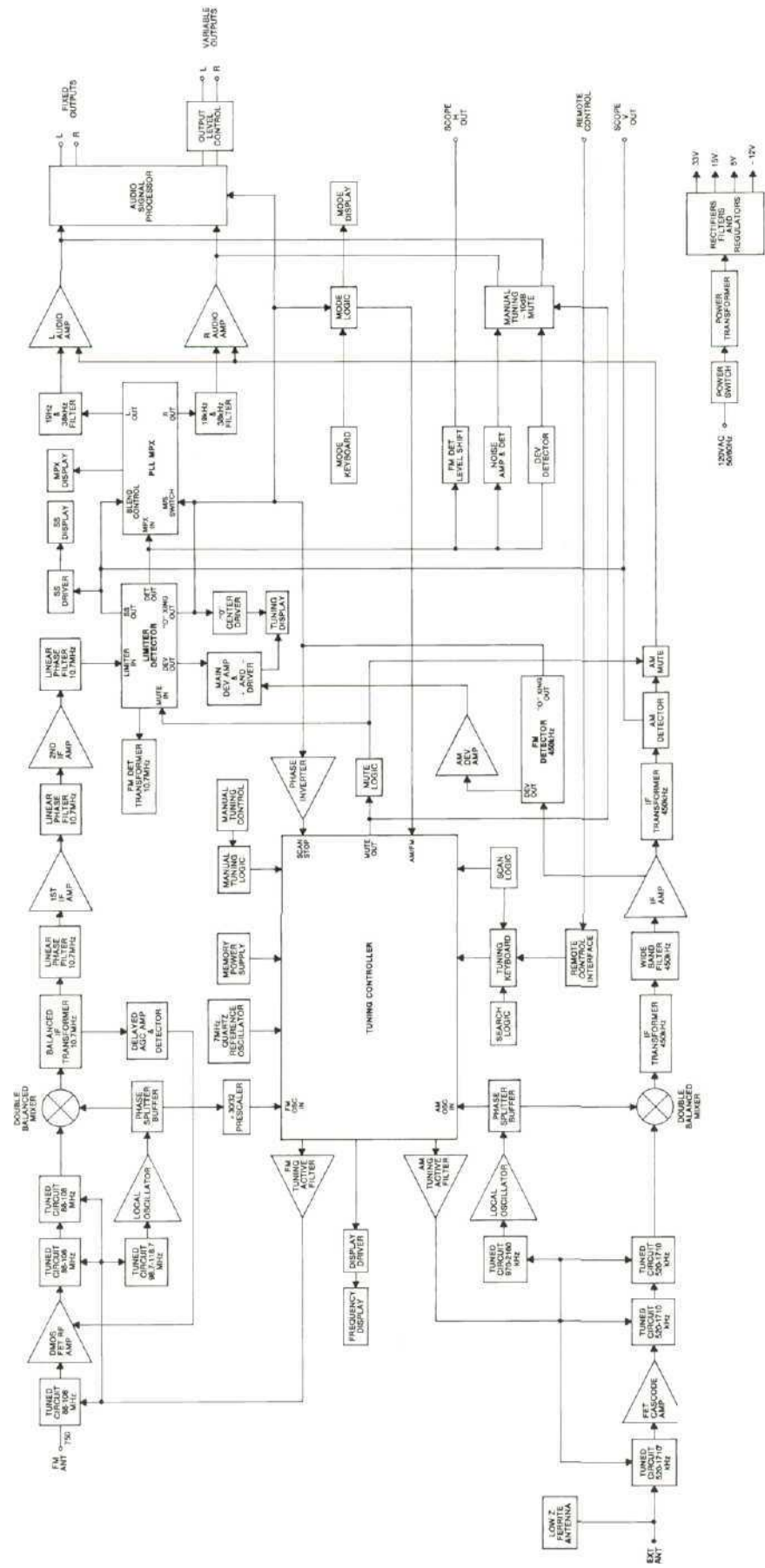

THE LOCATION OF CONTROLS

The numbers and letters correspond to the paragraphs on pages 6, 7, 9 and 10

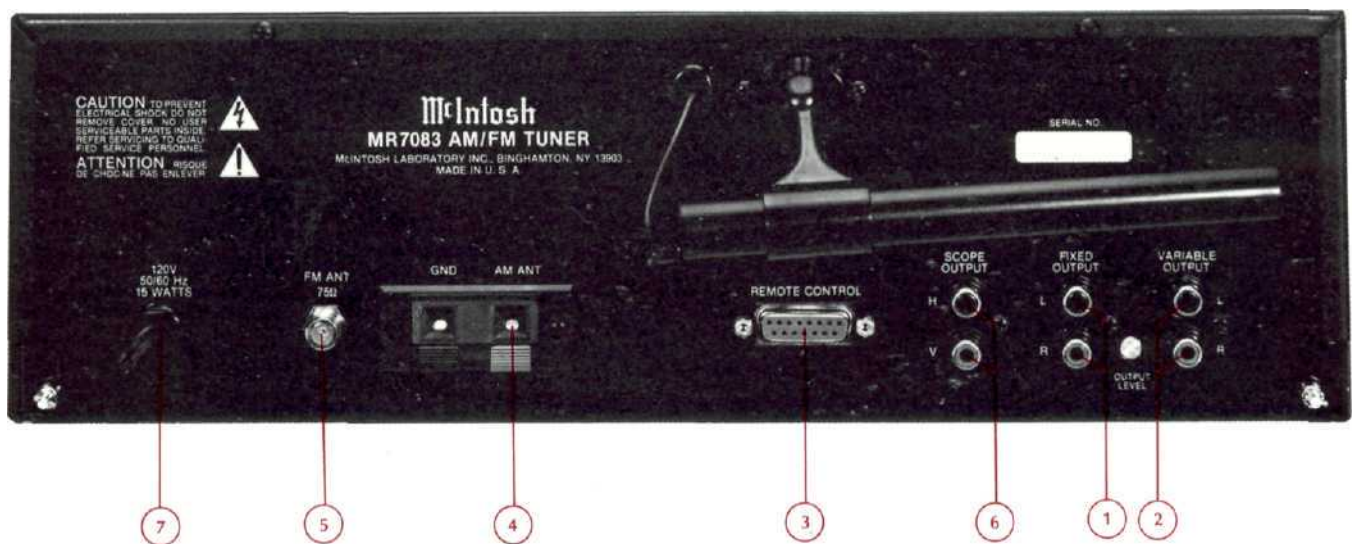
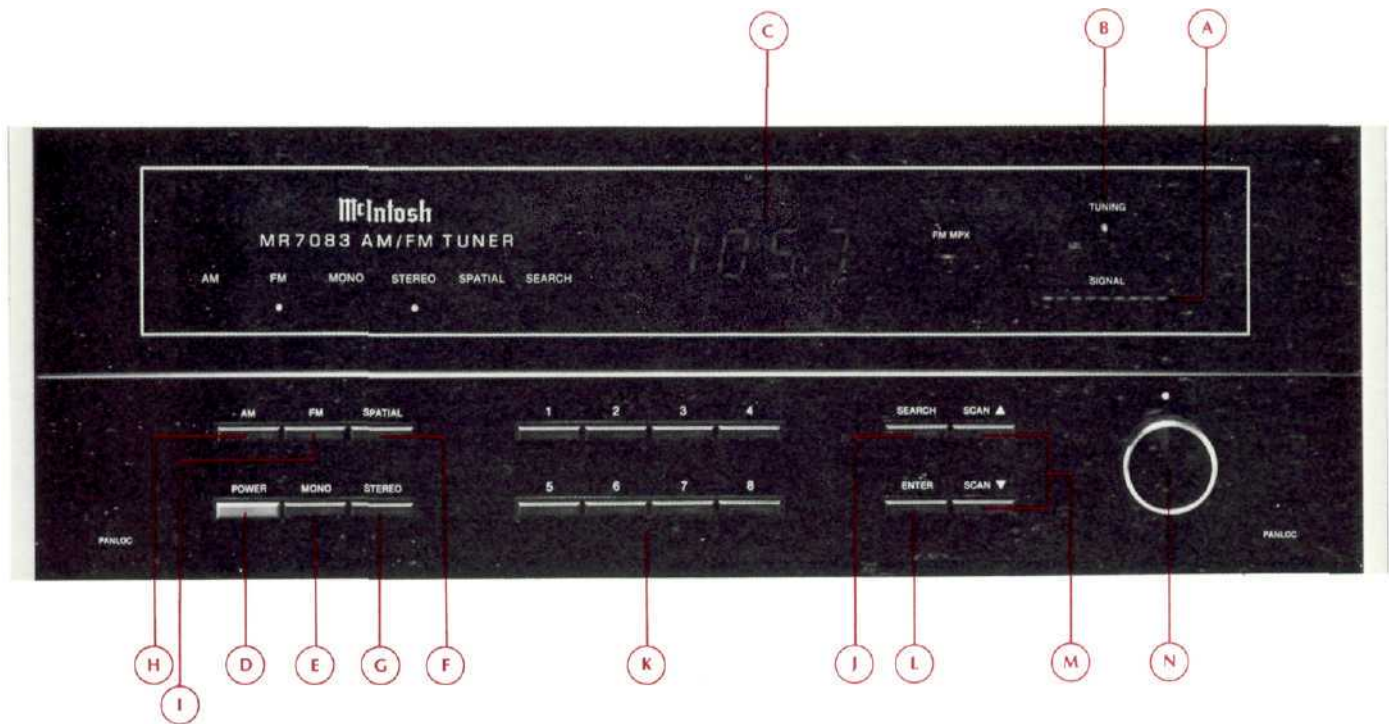

McIntosh®

McINTOSH LABORATORY INC.
2 CHAMBERS ST., BINGHAMTON, NY 13903-2699

The continuous improvement of its products is the policy of McIntosh Laboratory Incorporated who reserve the right to improve design without notice.
Printed in U.S.A.

039677
BE062003