

**McIntosh<sup>®</sup>**  
OWNER'S MANUAL

**MC7108  
EIGHT  
CHANNEL  
POWER  
AMPLIFIER**

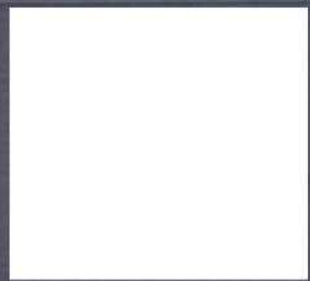

OWEN'S MANUAL

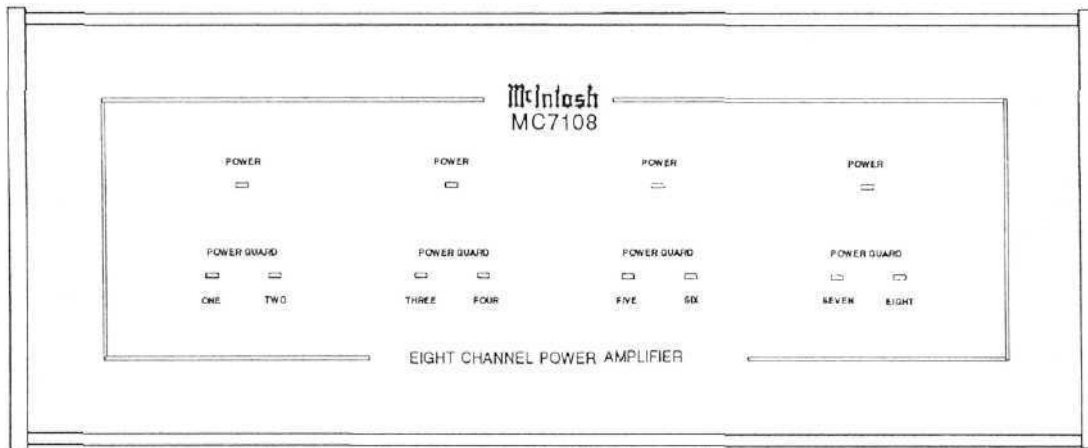

**MC7108  
EIGHT  
CHANNEL  
POWER  
AMPLIFIER**

## IMPORTANT SAFETY INSTRUCTIONS

THESE  
INSTRUCTIONS  
ARE TO PROTECT  
YOU AND THE  
McINTOSH  
INSTRUMENT.  
BE SURE TO  
FAMILIARIZE  
YOURSELF  
WITH THEM

1. Read all instructions - Read the safety and operating instructions before operating the instrument.
2. Retain Instructions - Retain the safety and operating instructions for future reference.
3. Heed warnings - Adhere to warnings and operating instructions.
4. Follow Instructions - Follow all operating and use instructions.

**WARNING: TO REDUCE RISK OF FIRE OR ELECTRICAL SHOCK, DO NOT EXPOSE THIS INSTRUMENT TO RAIN OR MOISTURE.**

5. Power Sources - Connect the power supply only to the type described in the operating instructions or as marked on the unit.
6. Power-Cord Protection - Route power-supply cords so that they are not likely to be walked on or pinched by items placed upon or against them, paying particular attention to cords at plugs, convenience receptacles, and the point where they exit from the instrument.
7. Ventilation - Locate the instrument for proper ventilation. For example, the instrument should not be placed on a bed, sofa, rug, or similar surface that may block ventilation openings; or, placed in a built-in installation, such as a bookcase or cabinet, that may impede the flow of air through the ventilation openings.
8. Heat - Locate the instrument away from heat sources such as radiators, heat registers, stoves, or other appliance (including amplifiers) that produce heat.
9. Wall or Cabinet Mounting - Mount the instrument in a wall or cabinet only as described in the owner's manual.
10. Water and Moisture - Do not use the instrument near water - for example, near a bathtub, washbowl, kitchen sink, laundry tub, in a wet basement, or near a swimming pool, etc.
11. Cleaning - Clean the instrument by dusting with a dry cloth. Clean the panel with a cloth moistened with a window cleaner.
12. Object and Liquid Entry - Do not permit objects to fall and liquids to spill into the instrument through enclosure openings.
13. Nonuse Periods -Unplug the power cord from the AC power outlet when left unused for a long period of time.
14. Damage Requiring Service - **Service must be performed by qualified service personnel when:**
  - A. The power supply cord or the plug has been damaged; or
  - B. Objects have fallen, or liquid has been spilled into the instrument; or
  - C. The instrument has been exposed to rain; or
  - D. The instrument does not appear to operate normally or exhibits a marked change in performance; or
  - E. The instrument has been dropped, or the enclosure damaged.
15. Servicing - Do not attempt to service beyond that described in the operating instructions. All other service should be referred to qualified service personnel.
16. Grounding or Polarization - Do not defeat the inherent design features of the polarized plug. Non-polarized line cord adaptors will defeat the safety provided by the polarized AC plug.
17. **CAUTION: TO PREVENT ELECTRICAL SHOCK DO NOT USE THIS (POLARIZED) PLUG WITH AN EXTENSION CORD, RECEPTACLE OR OTHER OUTLET UNLESS THE BLADES CAN BE FULLY INSERTED TO PREVENT BLADE EXPOSURE.**

**ATTENTION: POUR PREVENIR LES CHOCS ELECTRIQUES PAS UTILISER CETTE FICHE POLARISEE AVEC UN PROLONGATEUR, UNE PRISE DE COURANT OU UNE AUTRE SORTIE DE COURANT, SAUF SI LES LAMES PEUVENT ETRE INSEREES A FOND SANS EN LAISSER AUCUNE PARTIE A DECOUVERT.**



The lightning flash with arrowhead, within an equilateral triangle, is intended to alert the user to the presence of uninsulated "dangerous voltage" within the product's enclosure that may be of sufficient magnitude to constitute a risk of electric shock to persons.



**CAUTION: TO PREVENT THE RISK OF ELECTRIC SHOCK, DO NOT REMOVE COVER (OR BACK). NO USER-SERVICABLE PARTS INSIDE. REFER SERVICING TO QUALIFIED PERSONNEL.**



The exclamation point within an equilateral triangle is intended to alert the user to the presence of important operating and maintenance (servicing) instructions in the literature accompanying the appliance.

**WARNING: THIS UNIT IS CAPABLE OF PRODUCING HIGH SOUND PRESSURE LEVELS. CONTINUED EXPOSURE TO HIGH SOUND PRESSURE LEVELS CAN CAUSE PERMANENT HEARING IMPAIRMENT OR LOSS. USER CAUTION IS ADVISED AND EAR PROTECTION IS RECOMMENDED WHEN PLAYING AT HIGH VOLUMES.**

Your decision to own this piece of McIntosh Stereo Equipment ranks you at the very top among discriminating music listeners. You now have "The Best". The McIntosh dedication to "Quality", is assurance that you will receive thousands of hours of musical enjoyment from this unit.

Please take a short time to read the information in this manual. We want you to be as familiar as possible with all the features and functions of your new piece of McIntosh. This will ensure that you receive all the performance benefits this instrument can offer you, and that it will become a highly valued part of your home music system.

The serial number, purchase date, and McIntosh Laboratory Service Contract number are important to you for possible insurance claim or future service. Record this information here-

Serial Number

Purchase Date

Service Contract Number

Upon application, McIntosh Laboratory provides a Service Contract to the original purchaser. Your McIntosh Authorized Service Agency can expedite repairs when you provide the Service Contract with the instrument for repair.

SERVICE CONTRACT	4
INTRODUCTION	5
HOW TO INSTALL THE MC7108	5
FRONT PANEL DISPLAYS	6
REAR PANEL AND HOW TO MAKE CONNECTIONS	6, 7, 8, 9, 10
CUSTOM INSTALLATION DIAGRAMS	10
SPEAKER-AMPLIFIER CONNECTION DIAGRAMS	11, 12, 13, 14, 15, 16, 17
SPECIFICATIONS	18

**THANK  
YOU**

**TABLE OF  
CONTENTS**

**McINTOSH  
THREE YEAR  
SERVICE  
CONTRACT**

**TAKE ADVANTAGE OF 3 YEARS OF CONTRACT SERVICE  
FILL IN THE APPLICATION NOW.**

Your MC7108 Eight Channel Power Amplifier will give you many years of satisfactory performance. If you have any questions, please contact,

**McIntosh Laboratory Inc.**

2 Chambers Street  
Binghamton, New York 13903-2699  
Phone: 607-723-3512

An application for A THREE YEAR SERVICE CONTRACT is included with this manual. The terms of the contract are:

1. If the instrument covered by this contract becomes defective, McIntosh will provide all parts, materials, and labor needed to return the measured performance of the instrument to the original performance limits free of any charge. The service contract does not cover any shipping costs to and from the authorized service agency or the factory.
2. Any McIntosh authorized service agency will repair all McIntosh instruments at normal service rates. To receive the free service under the terms of the service contract, the service contract certificate must accompany the instrument when taken to the service agency.
3. Always have service done by a McIntosh authorized service agency. *// the instrument is modified or damaged as a result of unauthorized repair the service contract will be cancelled.* Damage by improper use or mishandling is not covered by the service contract.
4. The service contract is issued to you as the original purchaser. To protect you from misrepresentation this contract cannot be transferred to a second owner.
5. Units in operation outside the United States and Canada are not covered by the McIntosh Factory Service Contract, irrespective of the place of purchase. Nor are units acquired outside the USA and Canada, the purchasers of which should consult with their dealer to ascertain what, if any, service contract or warranty may be available locally.

## INTRODUCTION

McIntosh Laboratory has earned a world wide reputation for its technical contributions to improved sound reproduction. The technical innovations in McIntosh products have integrity proven by time. The McIntosh "Classic" design is recognized as the most outstanding in the industry.

McIntosh products are designed to be maximum user friendly so anyone can enjoy using them. They are also designed for easy maintenance. The legendary reliability of McIntosh products has been a matter of record since 1949.

The MC 7108, Eight Channel, 5-Way Power Amplifier can be operated in five different configurations. Each of the eight channels can be operated individually, in Mono pairs or Bridged pairs into either 8 or 4 ohm loads. Each of the 8 channels of the MC7108 can produce 40 watts into a 4 ohm load. Each of the 4 bridged pairs can produce 100 watts into 4 ohm loads.

### MC7108 OUTPUT OPERATING CONFIGURATIONS

(4 ohm loudspeaker loads)

1. 8-40 watt channels
2. 6-40 watt channels and 1 - 100 watt bridged pair channel
3. 4-40 watt channels and 2 - 100 watt bridged pair channels
4. 2-40 watt channels and 3 • 100 watt bridged pair channels
5. 4 - 100 watt bridged pair channels

### CHANNEL MODES

*Each of the four pairs of channels has a three position MODE switch. In STEREO mode, each channel can be operated as a separate mono amplifier, or as four stereo pairs. In MONO mode, the two (separate) stereo signals are combined to mono in each channel. The volume level of each mono channel of the pair can be controlled by its own LEVEL control. The BRIDGED mode combines the two channels in bridged configuration as described above.*

Operating configuration Number 1 is ideal for a multi-area remote controlled audio system. The four pairs of channels make an ideal power amplifier to operate the four remote areas controlled by a McIntosh CR10 Remote Control System.

Operating configuration Number 1 is also ideal for a McIntosh Home Theater System using the MC7108 together with a McIntosh C39 or MX 130 Audio/Video Control Center. A rear panel connector accepts a 25 conductor computer type cable that will connect to a C39 or MX130 A/V Control Center to receive all six channels of audio for a McIntosh Home Theater System. Each of the six audio signals are fed to six of the MC7108 channels in the order specified in the manual section describing the rear panel connections.

Operating configuration Number 4 is ideal for a McIntosh Home Theater System using the MC7108 together with the McIntosh MX 118 Audio/Video Tuner Control Center. The five Dolby Surround Pro Logic™ processed soundtracks are reproduced in the following manner. Three bridged 100 watt pairs can be used for the Left Front, Center and Right Front loudspeakers. The remaining two 40 watt channels can be used for the Left and Right Surround loudspeakers.

The MC7108 can be placed upright on a table or shelf, standing on its four plastic feet. The amplifier can also be custom installed in a cabinet of your choice. The mounting panel cutout, mounting shelf ventilation cutout and amplifier dimensions are shown in the diagrams found on a page further back in this manual.

Always provide adequate ventilation for the amplifier. The trouble free life of any electronic instrument is greatly extended by providing sufficient ventilation for proper cooling.

## HOW TO INSTALL THE MC7108

## HOW TO INSTALL THE MC7108

Allow at least 1-1/2 inches (3,8cm) above the heat sink area to allow the free flow of air. The recommended minimum depth for mounting, including clearance for connectors, is 20 inches (51cm) behind the front mounting panel. Clearance required in front of the mounting panel surface is 1 inch (2.54cm). **If mounted in a custom cabinet, cut out a ventilation hole in the amplifier mounting shelf according to the recommended dimensions.**

## FRONT PANEL DISPLAY

A front panel Red LED indicator is provided for each of the four pairs of channels. This indicator turns on when the speaker relays for that specific channel pair turn on.

All eight channels of the MC7108 incorporate the McIntosh POWER GUARD circuit which prevents output clipping with its harsh and damaging distortion. A front panel LED Power Guard indicator is provided for each of the eight channels. The LED lights whenever the power Guard circuit is activated for any particular channel. This indicates that the amplifier is producing its maximum undistorted power output, and that you are being protected from overdrive and clipping. The output level where Power Guard acts will be well above the rated power due to conservative McIntosh design philosophy.

*(If the POWER GUARD indicators turn on and stay on continuously for any given pair of channels, it indicates a problem is present. If this condition occurs, contact your McIntosh dealer for assistance.)*

## REAR PANEL AND HOW TO MAKE CONNECTIONS

Use high quality input and output connecting cables. Proper cables will insure receiving the best possible performance from your McIntosh system. Your McIntosh dealer can advise you on the types and lengths of cables that will work best in your installation,

Hookup drawings are included which give graphic information on how to connect the inputs and outputs for each installation configuration. Pay special attention to the polarities of the speaker hookups.

***Refer to the numbers on the rear panel drawing for the descriptions of the MC7108 connections and controls.***

### **1. POWER (ON, OFF/REMOTE)**

ON position turns the MC7108 AC power on. OFF/REMOTE allows the MC7108 AC power to be turned on by a DC Logic 1 control signal from a McIntosh Control Center or similar compatible accessory, to the POWER CONTROL IN connector.

### **2. CHANNELS 7 and 8, IN - OUT**

BRIDGED: Connect a cable from a Preamplifier or Control Center to 7 IN.

STEREO: Connect cables from the stereo outputs of a Preamplifier, Control Center or other accessory component to 7 IN and 8 IN.

MONO: Connect cables from the stereo outputs of a Preamplifier or Control Center to 7 IN and 8 IN. The stereo signals will be combined to Mono and fed to each amplifier channel. The two LEVEL controls will work separately on each channel.

*The OUT jacks provide a convenient connection to feed the same signals to other channels on the MC7108, or to any accessory component.*



### **3. LEVEL (BRIDGED, STEREO and MONO)**

**BRIDGED:** Use only the 7 BRIDGED LEVEL control and adjust as desired.

**STEREO:** Adjust the individual 7 and 8 LEVEL controls as desired. The 2.5V setting is suggested when the MC7108 is being used with a McIntosh Preamplifier or Control Center.

**MONO:** Adjust the individual 7 and 8 LEVEL controls as desired. The combined 7 and 8 Mono signals will be reproduced by each channel.

### **4. MODE (BRIDGED, STEREO and MONO)**

Set the MODE switch to the position for the desired operating configuration.

### **5. CHANNELS 5 and 6, IN - OUT**

**BRIDGED:** Connect a cable from a Preamplifier or Control Center to 5 IN.

**STEREO:** Connect cables from the stereo outputs of a Preamplifier, Control Center or other accessory component to 5 IN and 6 IN.

**MONO:** Connect cables from the stereo outputs of a Preamplifier or Control Center to 5 IN and 6 IN. The stereo signals will be combined to Mono and fed to each amplifier channel. The two LEVEL controls will work separately on each channel.

*The OUT jacks provide a convenient connection to feed the same signals to other channels on the MC7108, or to any accessory component.*

### **6. LEVEL (BRIDGED, STEREO and MONO)**

**BRIDGED:** Use only the 5 BRIDGED LEVEL control and adjust as desired.

**STEREO:** Adjust the individual 5 and 6 LEVEL controls as desired. The 2.5V setting is suggested when the MC7108 is being used with a McIntosh Preamplifier or Control Center.

**MONO:** Adjust the individual 5 and 6 LEVEL controls as desired. The combined 5 and 6 Mono signals will be reproduced by each channel.

### **7. MODE (BRIDGED, STEREO and MONO)**

Set the MODE switch to the position for the desired operating configuration.

### **8. 8 CHANNEL IN**

This connector will accept the outputs of the six audio channels of a McIntosh C39 or MX 130 A/V Control Center for use in a McIntosh Home Theater System. Use a male-to-female 25 conductor subminiature "D" (D825) shielded computer type cable from the 8 CHANNEL connector to the 25 pin 6 CHANNEL connector on a McIntosh C39 or MX130. The six separate outputs from the Control Centers will appear at the MC7108 in the following channel allocation. A power control signal to turn the MC7108 power on and off is also sent on the cable from the Control Center.

*CHANNEL 1: Center Front*

*CHANNEL 2: Left Surround*

*CHANNEL 3: Left Front*

*CHANNEL 4: Right Front*

*CHANNEL 5: Subwoofer*

*CHANNEL 6: Right Surround*

Connect discrete cables from a C39 or MX130 Area "B" OUTPUTS to channels 7 and 8 to drive loudspeakers in the remote Area "B".

### **9. POWER CONTROL, IN/OUT**

The MC7108 AC power can be turned on and off by a control signal fed to the POWER

## REAR PANEL AND HOW TO MAKE CONNECTIONS

CONTROL IN connector from the POWER CONTROL OUT connector on compatible McIntosh products. The MC7108 POWER CONTROL OUT jack will feed the same AC power control signal out, delayed 0.2 seconds, to turn on and off another accessory component with a compatible Power Control input.

The MC7108 POWER switch must be in the OFF/REMOTE setting for the power control signals to turn the MC7108 On and Off.

*The POWER CONTROL connectors are standard 1/8 inch mini phone plugs. Only the tip and sleeve are used for connecting the plug to a single conductor shielded cable.*

### **10. CHANNELS 3 and 4, IN - OUT**

BRIDGED: Connect a cable from a Preamplifier or Control Center to 3 IN.

STEREO: Connect cables from the stereo outputs of a Preamplifier, Control Center or other accessory component to 3 IN and 4 IN.

MONO: Connect cables from the stereo outputs of a Preamplifier or Control Center to 3 IN and 4 IN. The stereo signals will be combined to Mono and fed to each amplifier channel. The two LEVEL controls will work separately on each channel.

*The OUT jacks provide a convenient connection to feed the same signals to other channels on the MC7108, or to any accessory component.*

### **11. LEVEL (BRIDGED, STEREO and MONO)**

BRIDGED: Use only the 3 BRIDGED LEVEL control and adjust as desired.

STEREO: Adjust the individual 3 and 4 LEVEL controls as desired. The 2.5V setting is suggested when the MC7108 is being used with a McIntosh Preamplifier or Control Center.

MONO: Adjust the individual 3 and 4 LEVEL controls as desired. The combined 3 and 4 Mono signals will be reproduced by each channel.

### **12. MODE (BRIDGED, STEREO and MONO)**

Set the MODE switch to the position for the desired operating configuration.

### **13. CHANNELS 1 and 2, IN - OUT**

BRIDGED: Connect a cable from a Preamplifier or Control Center to 1 IN.

STEREO: Connect cables from the stereo outputs of a Preamplifier, Control Center or other accessory component to 1 IN and 2 IN.

MONO: Connect cables from the stereo outputs of a Preamplifier or Control Center to 1 IN and 2 IN. The stereo signals will be combined to Mono and fed to each amplifier channel. The two LEVEL controls will work separately on each channel.

*The OUT jacks provide a convenient connection to feed the same signals to other channels on the MC7108, or to any accessory component.*

### **14. LEVEL (BRIDGED, STEREO and MONO)**

BRIDGED: Use only the 1 BRIDGED LEVEL control and adjust as desired.

STEREO: Adjust the individual 1 and 2 LEVEL controls as desired. The 2.5V setting is suggested when the MC7108 is being used with a McIntosh Preamplifier or Control Center.

MONO: Adjust the individual 1 and 2 LEVEL controls as desired. The combined 1 and 2 Mono signals will be reproduced by each channel.

### **15. MODE (BRIDGED, STEREO and MONO)**

Set the MODE switch to the position for the desired operating configuration.

## **16. AC POWER CORD**

Connect the MC7108 to a live 50/60HZ, 120 volt AC wall outlet or a Power Control Relay. Do not connect the unit to an AC outlet on the rear panel of a Preamplifier or Control Center. The AC power can also be turned on and off by sending a signal to the POWER CONTROL IN jack. (Refer to "1", POWER and "9", POWER CONTROL, IN-OUT)

## **17. 8A 250V (Fuse)**

CAUTION: For continued protection against fire hazard, replace only with the same type 8A-250V SLO BLO fuse.

*All MC7108 outputs are in phase with the inputs.*

## **18. CHANNEL 7 and 8 OUTPUTS**

**Stereo and Mono:** Connect cables from each loudspeaker Common terminal to the Minus (-) or Common terminals for channels 7 and 8. Connect cables from each loudspeaker positive terminal to the Positive (+) terminals for channels 7 and 8. Be sure to observe the polarity markings and connect both channels in an identical manner. Most loudspeakers usually have their Common or Minus terminals color coded Black and the Positive or Hot terminals coded Red.

**Bridged Pair:** Connect a cable from the Common loudspeaker terminal to the MINUS (-) BRIDGED terminal, (Channel 8 +). Connect a cable from the Positive loudspeaker terminal to the Positive (+) BRIDGED terminal, (Channel 7 +).

## **19. CHANNEL 5 AND 6 OUTPUTS**

**Stereo and Mono:** Connect cables from each loudspeaker Common terminal to the Minus (-) or Common terminals for channels 5 and 6. Connect cables from each loudspeaker positive terminal to the Positive (+) terminals for channels 5 and 6. Be sure to observe the polarity markings and connect both channels in an identical manner. Most loudspeakers usually have their Common or Minus terminals color coded Black and the Positive or Hot terminals coded Red.

**Bridged Pair:** Connect a cable from the Common loudspeaker terminal to the MINUS (-) BRIDGED terminal, (Channel 6 +). Connect a cable from the Positive loudspeaker terminal to the Positive (+) BRIDGED terminal, (Channel 5 +).

## **20. MULTI ROOM CONTROL**

Connect an optional cable with DIN connectors on each end, (McIntosh Part No. 170-147) from the MULTI ROOM CONTROL CONNECTOR TO A McIntosh CR10 system, The control cable allows the CR10 to switch ON the MC7108 speaker relays, only for the remote areas that are active.

## **21. CHANNEL 3 AND 4 OUTPUTS**

**Stereo and Mono:** Connect cables from each loudspeaker Common terminal to the Minus (-) or Common terminals for channels 3 and 4. Connect cables from each loudspeaker positive terminal to the Positive (+) terminals for channels 3 and 4. Be sure to observe the polarity markings and connect both channels in an identical manner. Most loudspeakers usually have their Common or Minus terminals color coded Black and the Positive or Hot terminals coded Red.

**Bridged Pair.** Connect a cable from the Common Loudspeaker terminal to the MINUS (-) BRIDGED terminal, (Channel 4 +). Connect a cable from the Positive loudspeaker terminal to the Positive (+) BRIDGED terminal, (Channel 3 +).

**REAR PANEL  
AND HOW  
TO MAKE  
CONNECTIONS**

**22. CHANNEL 1 AND 2 OUTPUTS**

**Stereo and Mono:** Connect cables from each loudspeaker Common terminal to the Minus (-) or Common terminals for channels 1 and 2. Connect cables from each loudspeaker positive terminal to the Positive (+) terminals for channels 1 and 2. Be sure to observe the polarity markings and connect both channels in an identical manner. Most loudspeakers usually have their Common or Minus terminals color coded Black and the Positive or Hot terminals coded Red.

**Bridged Pair:** Connect a cable from the Common loudspeaker terminal to the MINUS (-) BRIDGED terminal, (Channel 2 +). Connect a cable from the positive loudspeaker terminal to the Positive (+) BRIDGED terminal, (Channel 1 +).

**CUSTOM  
INSTALLATION  
DIAGRAMS**

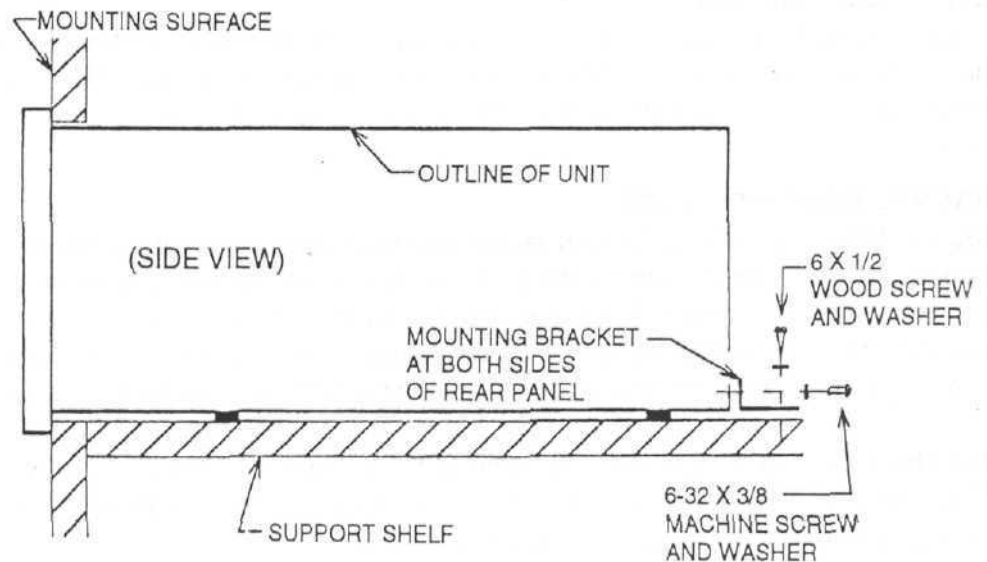
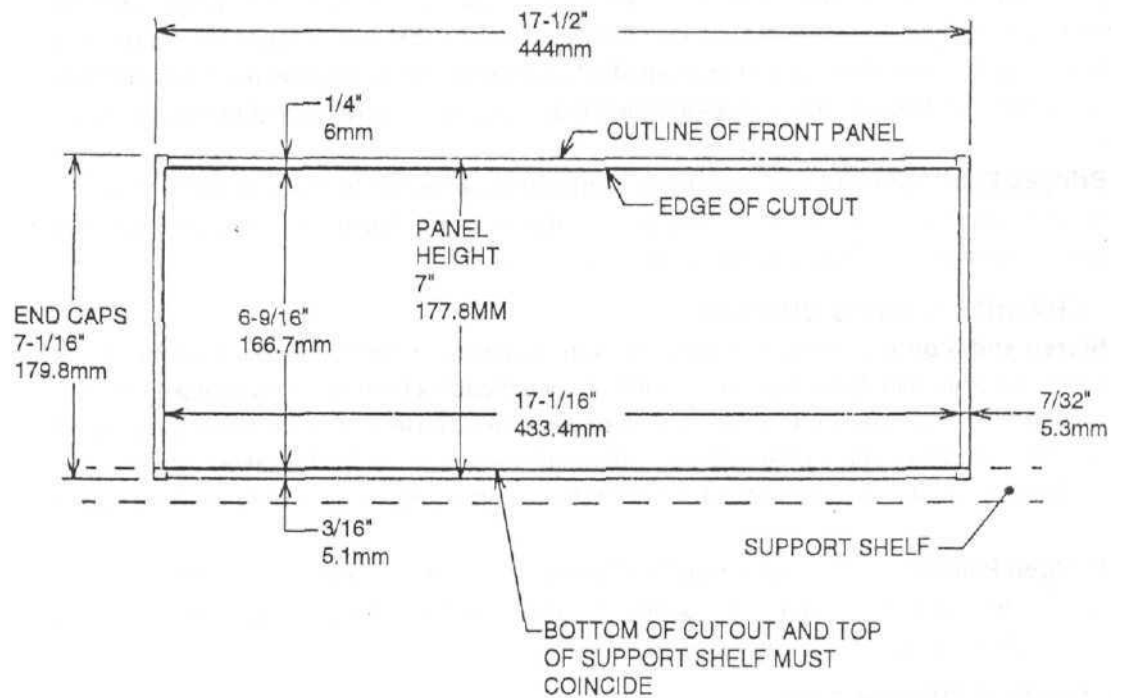

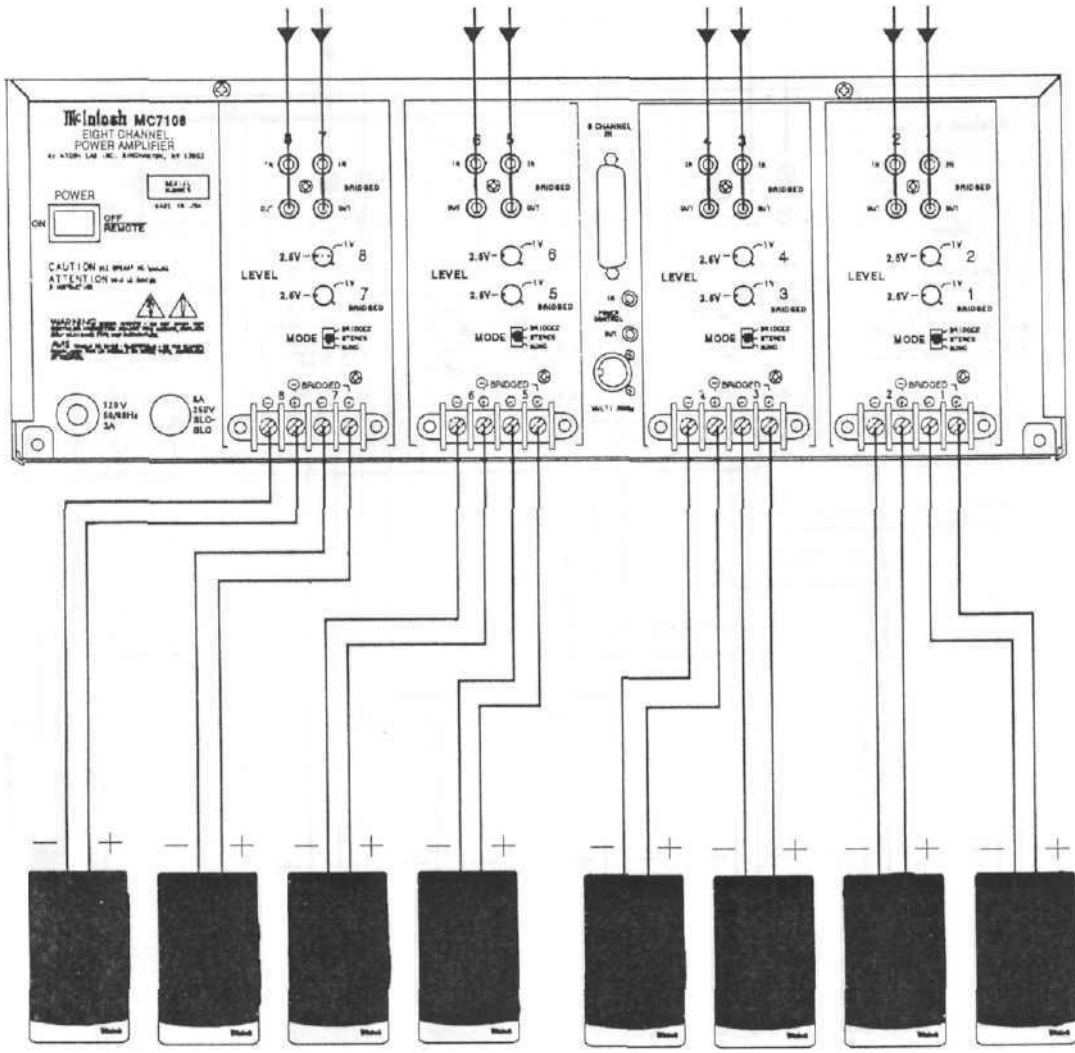

**EIGHT 40 WATT CHANNELS (4 PAIRS)**

**SIX 40 WATT  
CHANNELS AND  
ONE 100 WATT  
BRIDGED PAIR  
CHANNEL**

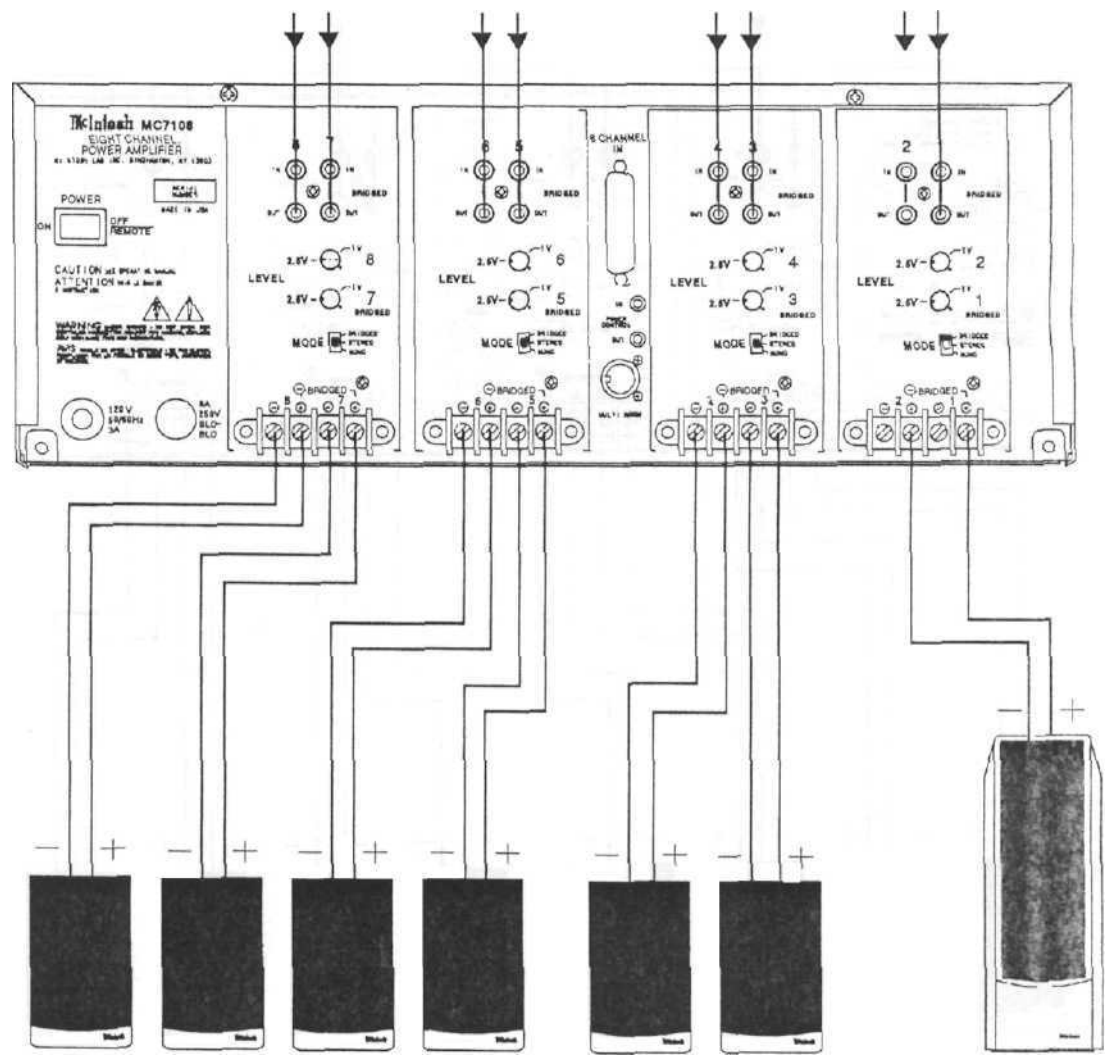

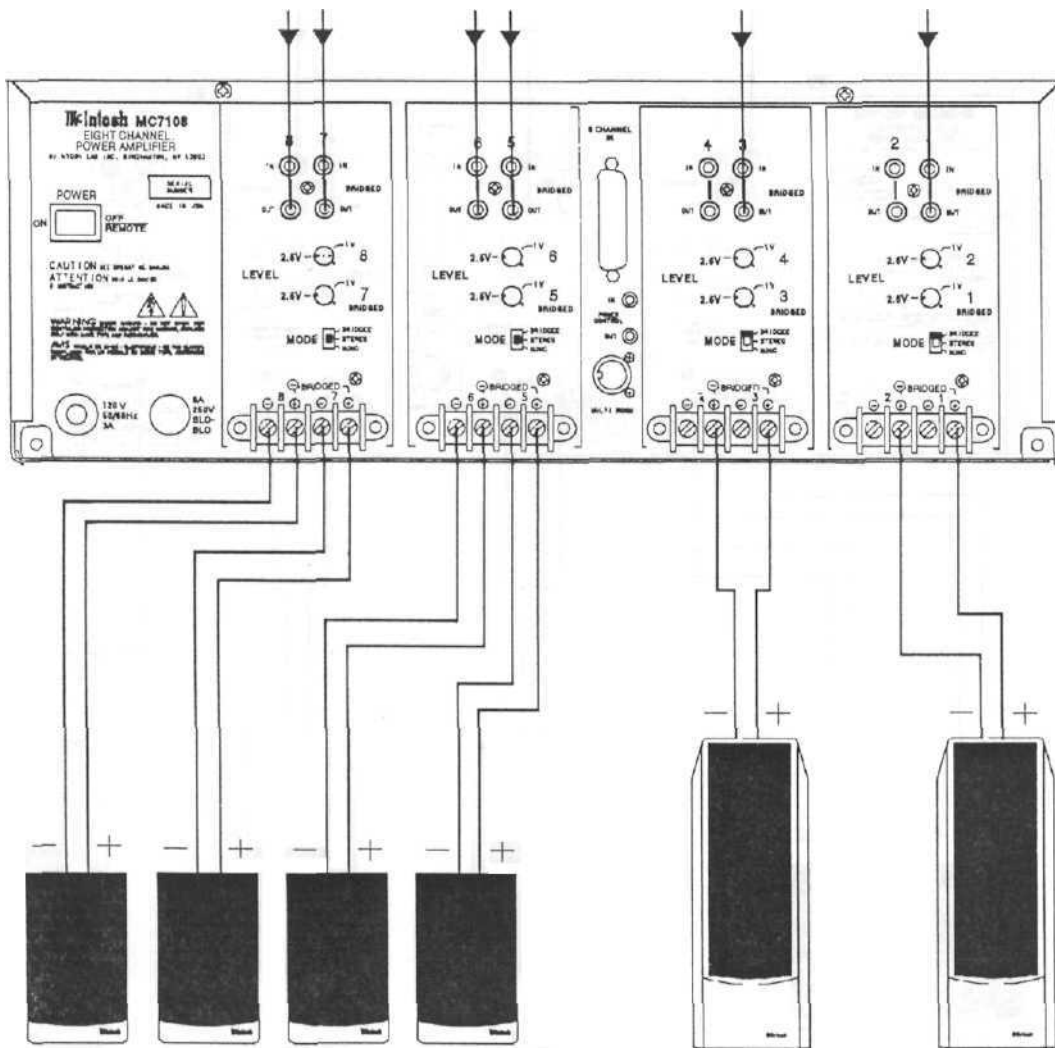

**FOUR 40 WATT  
CHANNELS AND  
TWO 100 WATT  
BRIDGED PAIR  
CHANNELS**

**TWO 40 WATT CHANNELS AND THREE 100 WATT BRIDGED PAIR CHANNELS**

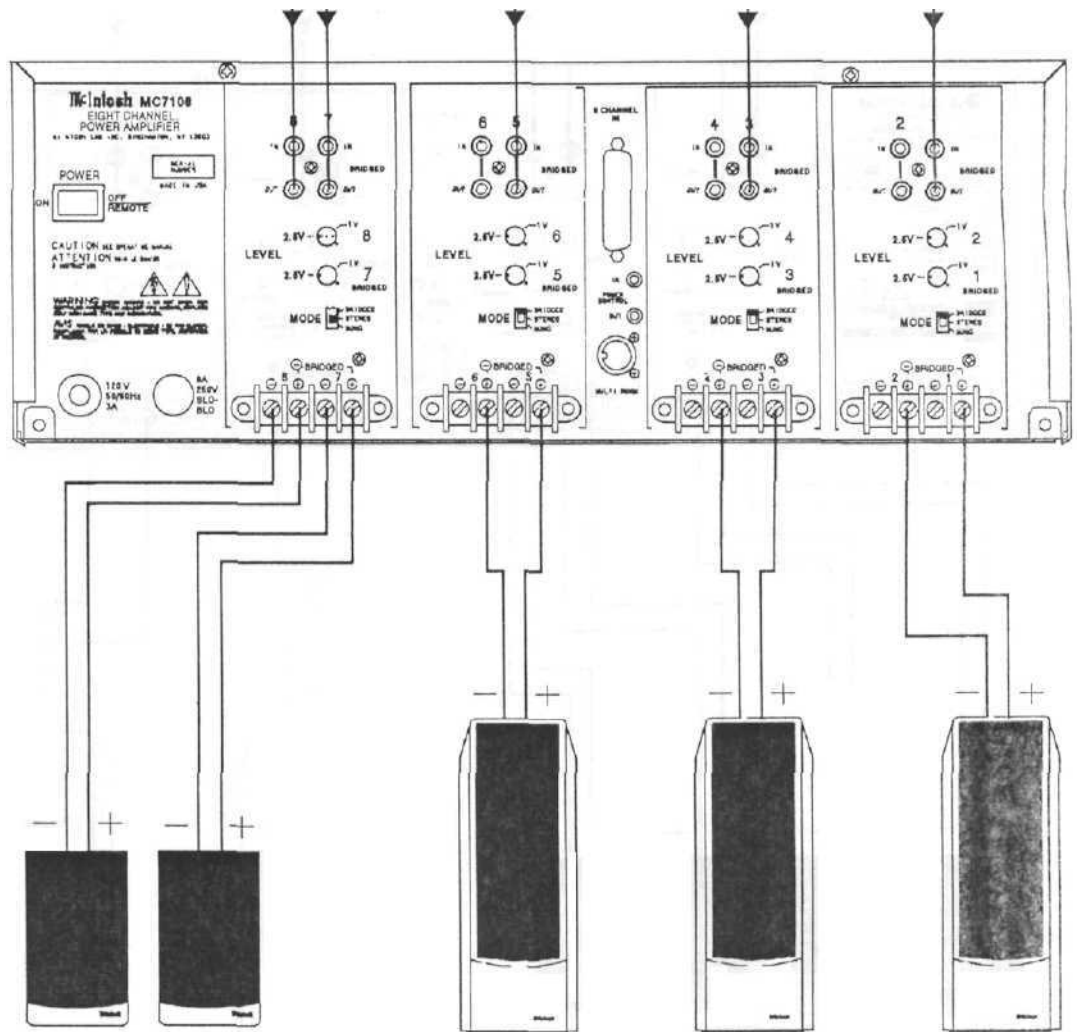



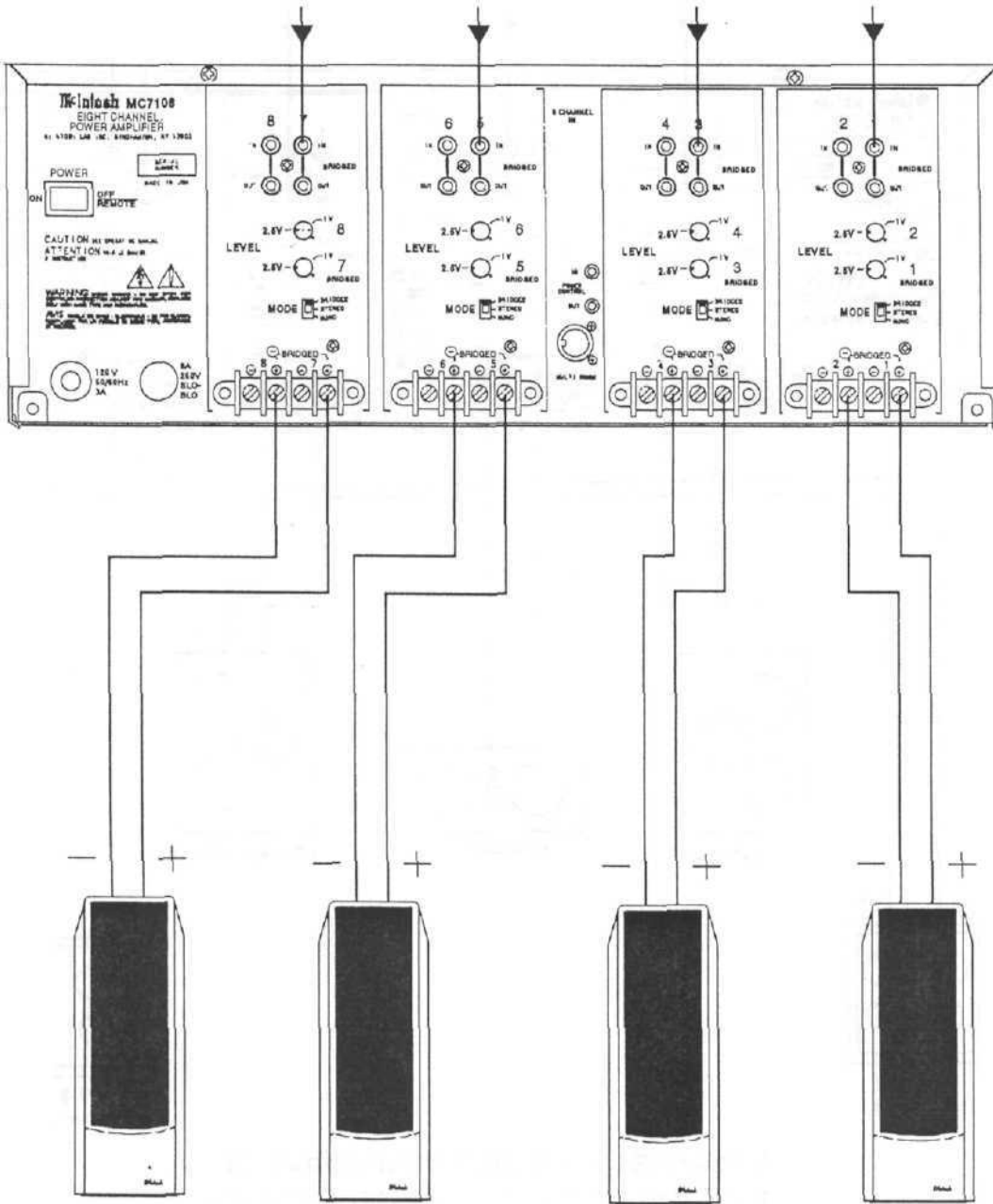

**FOUR 100 WATT  
BRIDGED PAIR  
CHANNELS**

**McINTOSH  
HOME THEATER  
SYSTEM #1**

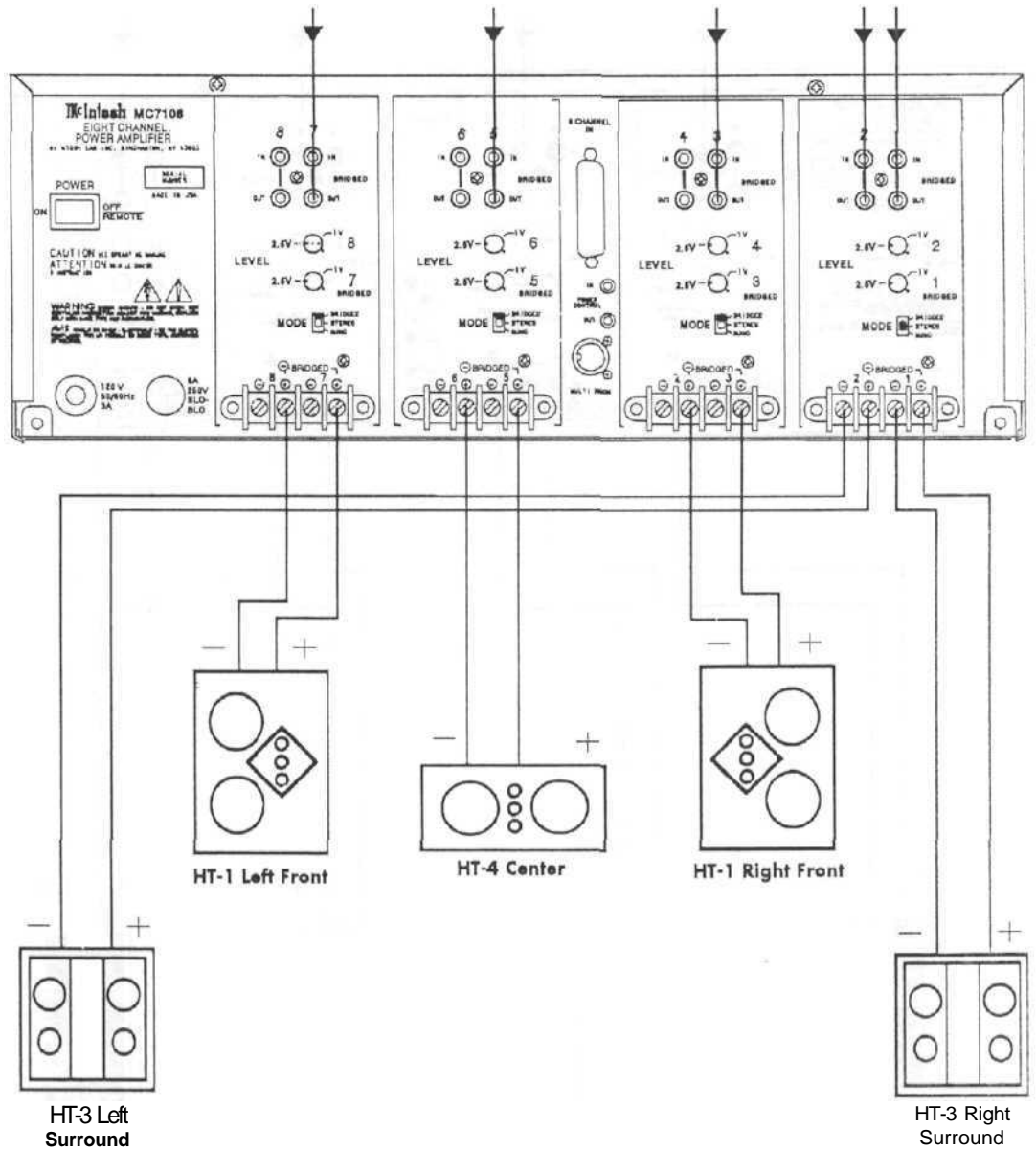

**5 CHANNEL OPERATING CONFIGURATION  
WITH MX118 A/V TUNER CONTROL CENTER**

**MCINTOSH  
HOME THEATER  
SYSTEM #2**

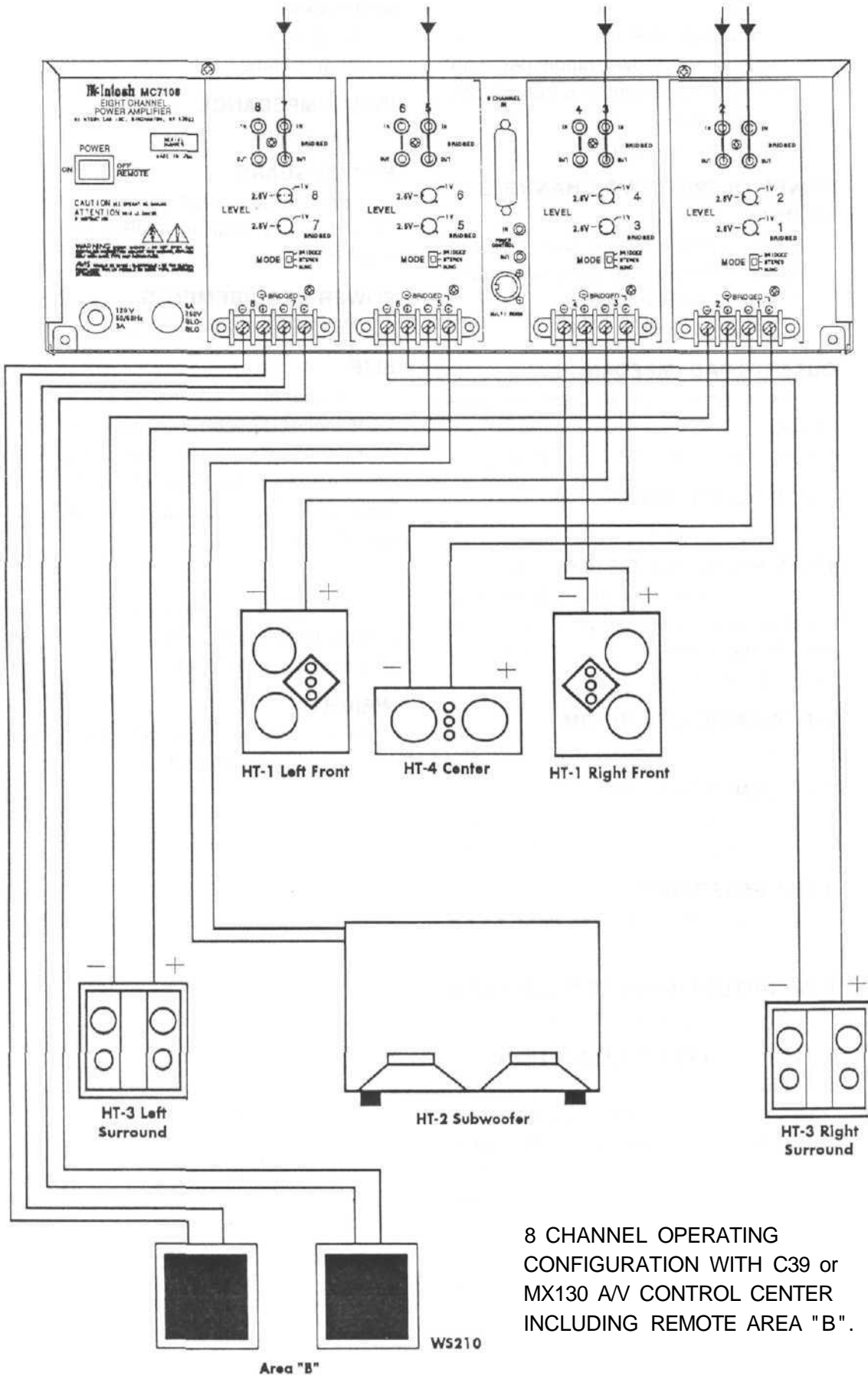

8 CHANNEL OPERATING  
CONFIGURATION WITH C39 or  
MX130 AV CONTROL CENTER  
INCLUDING REMOTE AREA "B".

## SPECIFICATIONS

### POWER OUTPUT, EIGHT CHANNELS

40 watts per channel, minimum sine wave continuous average power output per channel, all channels operating into 4 ohm loads.

The output RMS voltage is:  
12.6V across 4 ohms

### POWER OUTPUT, TWO CHANNELS BRIDGED

100 watts into a 4 ohm load, minimum sine wave continuous average power output.

The output RMS voltage is:  
20V across 4 ohms

### OUTPUT LOAD IMPEDANCE

8 or 4 ohms, for all eight separate channels

8 or 4 ohms, for all Bridged Pairs

### RATED POWER BAND

20Hz to 20,000Hz

### TOTAL HARMONIC DISTORTION

0.005% maximum harmonic distortion at any power level from 250mW to rated power per channel from 20Hz to 20,000Hz, all channels operating.

### IHF DYNAMIC HEADROOM

1.8dB

### FREQUENCY RESPONSE

+0, -0.25dB from 20Hz to 20,000Hz

+0, -3.0dB from 10Hz to 100,000Hz

### INPUT SENSITIVITY

1V, (2.5V with Level control at center detent)

### A WEIGHTED SIGNAL TO NOISE RATIO

92dB (112dB below rated output)

### INTERMODULATION DISTORTION, SMPTE

0.005% maximum if instantaneous peak power does not exceed twice the output power rating per channel, with all channels operating, for any combination of frequencies from 20Hz to 20,000Hz.

### WIDE BAND DAMPING FACTOR

200 at 8 ohms

100 at 4 ohms

### INPUT IMPEDANCE

20,000 ohms

### POWER GUARD

Clipping is prevented and THD does not exceed 2% with up to 14dB overdrive at 1000Hz.

### POWER REQUIREMENTS

120V, 50/60Hz, 8A UL/CSA

### SIZE

Front panel: 17-1/2 inches (44.5cm) W, 7-1/16 inches (17.9cm) H, 20 inches (50.8cm) D behind mounting panel, including clearance for connectors. Panel clearance required in front of mounting panel is 3/4 inch (1.9cm).

### FINISH

Front panel is glass with gold teal nomenclature illumination. Chassis and chassis cover are black.

### WEIGHT

40 pounds (18.1Kg) net, 58 pounds (28.3Kg) in shipping carton.

# RECOMMENDED VENTILATION CUTOUT IN MOUNTING SHELF

CUSTOM  
INSTALLATION  
DRAWING

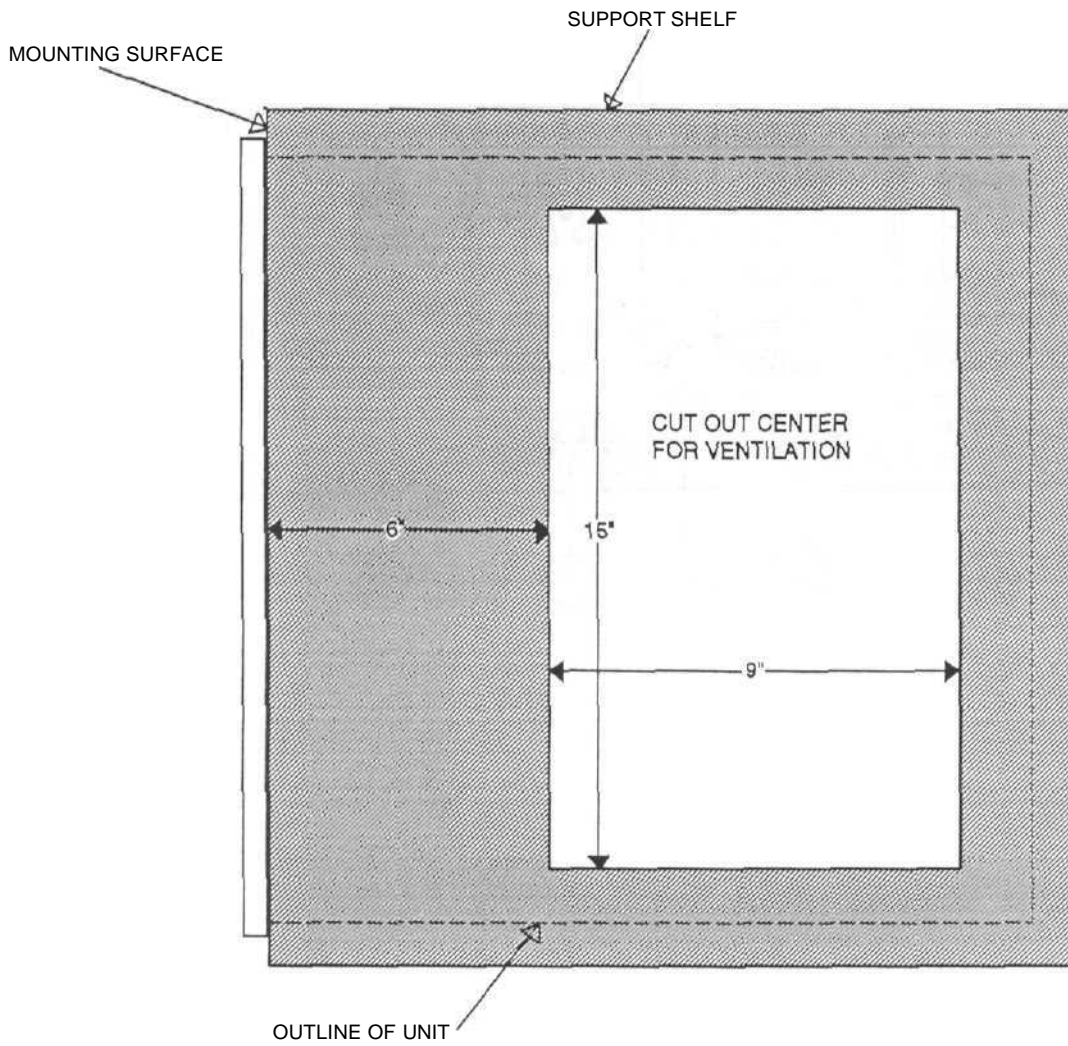

The numbers refer to the paragraphs on pages 6 through 9.

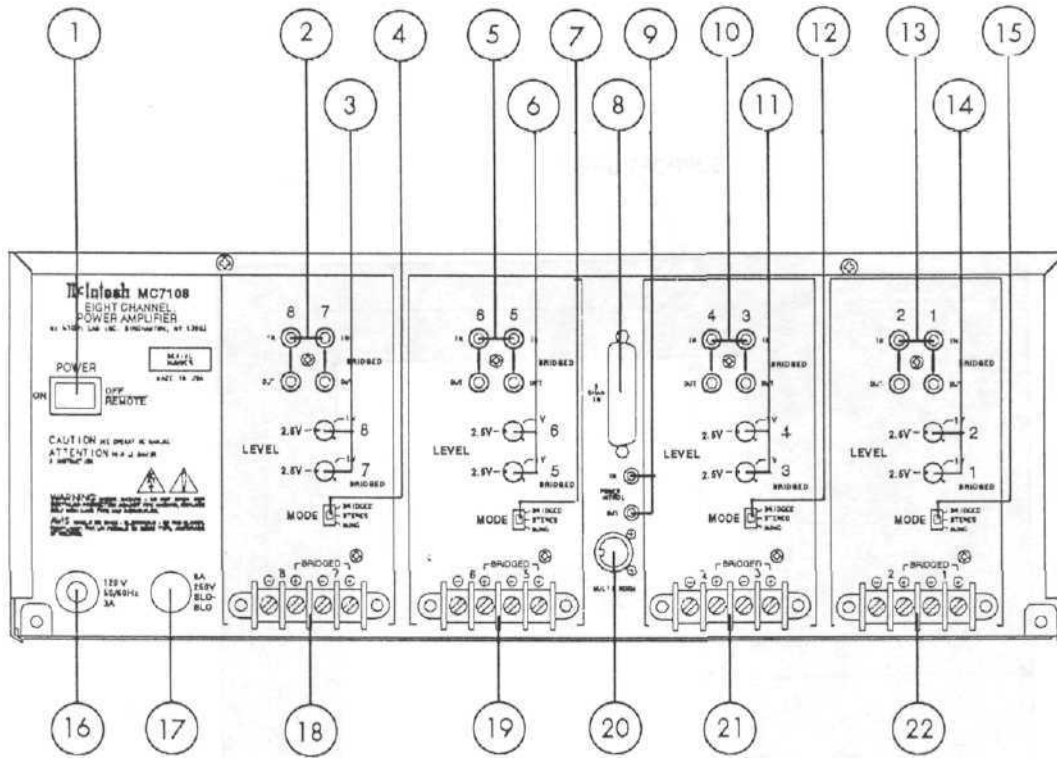







# Radon III

THE UNIVERSITY OF CHICAGO  
DIVISION OF PHYSICAL SCIENCES

PHYSICS DEPARTMENT  
5734 S. UNIVERSITY AVE., CHICAGO, ILL. 60637



McINTOSH LABORATORY INC.  
2 CHAMBERS STREET, BINGHAMTON, NEW YORK 13903-2699

The continuous improvement of its products is the policy of McIntosh Laboratory  
Incorporated who reserve the right to improve design without notice.  
Printed in the U.S.A.