

STEREO INTEGRATED AMPLIFIER

KA-6100

INSTRUCTION MANUAL



the sound approach to quality
KENWOOD

INTRODUCTION

The purpose of this manual is to acquaint you with the operating features this unit. You will notice that in every detail of planning, engineering, styling, operating convenience, and adaptability, we have sought to anticipate your needs and desires.

We suggest that you read through this manual carefully. Knowing how to set up the unit, to the best advantage, will enhance your listening pleasure right from the start. You will also become aware of the ease with which you can adjust the unit to meet your special requirements.

SERIAL NUMBER

Record your SERIAL NUMBER on the spaces designated on the warranty card. You will find the serial number on the back of the unit.

AFTER UNPACKING

After unpacking, we recommend you inspect and examine the unit for any possible shipping damage. If your unit is damaged or fails to operate, notify your dealer immediately. If your unit was shipped to you directly, notify the shipping company without delay. Only the consignee (the person or company receiving the unit) can file a claim against the carrier for shipping damage.

We recommend you retain the original carton and packing materials to prevent any damage should you transport or ship your unit in the future.

INSTALLATION PRECAUTIONS

- (a) Avoid locations subject to direct sunlight.
- (b) Avoid high or low temperature extremes.
- (c) Keep the unit away from heat radiating source.
- (d) Keep the unit at least 4 inches (about 10 centimeters) away from the wall and other things for ventilation.

WARNING:
TO PREVENT FIRE OR SHOCK HAZARD, DO NOT EXPOSE THIS APPLIANCE TO RAIN OR MOISTURE.

IMPORTANT!

1. Units shipped to U.S.A. and CANADA are designed to operate on 120 volts AC only. Therefore the above units are not equipped with an AC Voltage Selector Switch and the following description on such a switch should be disregarded.
2. Units shipped to all other countries are equipped with an AC Voltage Selector Switch on the rear panel. The following description should be carefully read.

AC VOLTAGE SELECTION

This unit operates on 110 – 120 volts or 220 – 240 volts AC. Before connecting the power cord to your AC outlet, make sure that the setting position of the AC Voltage Selector Switch matches your AC voltage. If not, it must be properly changed in accordance with the instructions below.

Note:

Our warranty does not cover damage caused by excessive AC voltage due to improper setting of the AC Voltage Selector Switch.

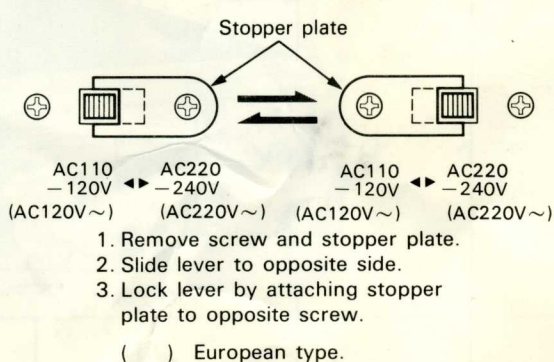

AC Voltage Selector Switch

CONTENTS

FEATURES	3
INTERCONNECTING DIAGRAM	4
CONNECTING INSTRUCTIONS.....	5
CONTROLS AND FUNCTIONS.....	6
OPERATING INSTRUCTIONS.....	8
MAINTENANCE	10
BEFORE ASKING SERVICE.....	11
SPECIFICATIONS/BLOCK DIAGRAM.....	12

FEATURES

1. LOW DISTORTION POWER AMPLIFIER SECTION

The power amplifier section is composed of a current mirror load differential amplifier, a class-A amplifier, and an inverted Darlington type pure complementary circuit.

The first stage is a transistorized differential amplifier to which a current mirror circuit is loaded. The current mirror circuit increases the gain at the first stage and assures low distortion and stability.

The power amplifier stage consists of an inverted Darlington type pure complementary circuit to improve the power supply efficiency and to obtain high output power.

If DC voltage exceeding specified limit is developed at the output terminal, the protective circuit turns off the relay to prevent the speakers from being damaged. This circuit also functions as a delay start circuit.

2. SEPARATION OF LEFT AND RIGHT CHANNELS POWER SUPPLY

This power supply system is of DPS (dual power supply) type with a 2-winding transformer. The power transformer uses a large sized EI core to provide excellent regulation. The combination of this transformer and a large filter capacitor forms a dual power supply system to supply power to L and R channels respectively.

This power supply system eliminates dynamic crosstalk as well as it assures reliable operation of the amplifier. The power supply unit for the preamplifier is equipped with a transistorized power voltage regulator to improve the circuit operation stability and the quality of sound.

3. TONE CONTROL CIRCUIT

The tone control circuit has FET at the first stage; it also contains dual power supply unit, 2-stage direct-coupled flat amplifier and bass/treble control circuit. This control circuit is so called BAX type NF control circuit that assures high stability and low distortion. The flat amplifier is of the ICL (input capacitorless) type to adjust bass and treble tones up to ± 7.5 dB at about 1.5 dB steps, thus enabling fine adjustment of tonal quality.

4. ICL EQUALIZER WITH FET CIRCUIT

This circuit is a simplified ICL circuit consisting of FET input amplifier, class-A amplifier and pure complementary SEPP amplifier.

The use of newly developed super low noise FET and cleverly designed circuit reduces the impedance of the entire circuit to improve S/N ratio to 86 dB (2.5 mV input, IHF A). The adoption of precision resistors and film capacitors provides RIAA characteristic with error of ± 0.3 dB.

5. SPECIAL TAPE-THROUGH CIRCUITRY

This unit has facilities for simultaneous recording by two tape decks and for dubbing from deck A to B. In addition, Kenwood's tape-through circuitry allows you to dub while listening to a different program source. This may not be a feature you will use every day, but it is quite practical and will be appreciated when the occasion arises.

6. LARGE POWER METERS VISUALLY SHOW OUTPUT POWER

With these full-size Power meters you always know what your amplifier is doing. You can visually check output and balance channels.

A refinement for audiophiles, these meters are large and illuminated for easy reading. Notice that sensitivity is adjustable for operation at both high and low levels to get maximum range in both cases. High: 0.1W to 80W; low, 0.01W to 3W.

7. TWO SPEAKER SYSTEMS

You can attach two speaker systems and select either or both.

8. LOUDNESS CONTROL

This control (+8 dB at 100 Hz) boosts especially the low frequency range at a low listening level and offers you splendid stereo reproduction.

9. BALANCE CONTROL

This control performs the volume adjustment of right/left speakers and headphones.

10. EXCELLENT DESIGN

Kenwood's excellence of design and superior craftsmanship is evident not only in the electronics of the unit but also in all the controls.

11. OTHERS

- 41-click master volume to suit audiophiles' tastes.
- Subsonic filter of 18 Hz, 6 dB/oct.

CONNECTING INSTRUCTIONS

SPEAKER CONNECTING AND SPEAKERS SWITCH

In connecting only one pair of speakers, connect the right speaker to "RIGHT" and left speaker to "LEFT" of the SPEAKERS A terminals. Should (+) or (-) of either right or left channel be reversely connected, sounds at the center section will be adversely affected by lack of separation. To connect an additional pair of speakers, connect right speaker to "RIGHT" and left speaker to "LEFT" of the SPEAKERS B terminals.

When connecting the speaker leads to the speaker terminals, make sure that the bare wires strands at the tips of the speaker leads do not touch each other or adjacent terminal.

It is recommended that the wires of individual cord lead tips are soldered, or they are stranded together to eliminate any possibility of short-circuits forming in the speaker connecting network.

Note:

Each speaker should be 4 ohms or more in impedance when only one pair of speakers are used. However, it should be 8 ohms or more when two pairs of speakers are used at the same time (A + B).

TURNTABLE CONNECTION

The two shielded audio cables from your stereo turntable are normally terminated with phono plugs. Connect the left channel of the turntable to "LEFT" of the PHONO input jack and the right channel to "RIGHT" of the PHONO input jack.

If the turntable has a grounding wire, connect it to this unit's GND terminal to avoid hum.

TUNER CONNECTION

Use the TUNER terminals for connection to an FM stereo or AM-FM stereo tuner.

Connect the left channel of the tuner to "LEFT" of the TUNER input jack and the right channel of the tuner to "RIGHT" of the TUNER input jack.

AUX (AUXILIARY INPUTS)

High level AUX input jacks are for miscellaneous sources, such as extra tape decks, additional tuners and/or receivers, TV sound outputs, and other external components.

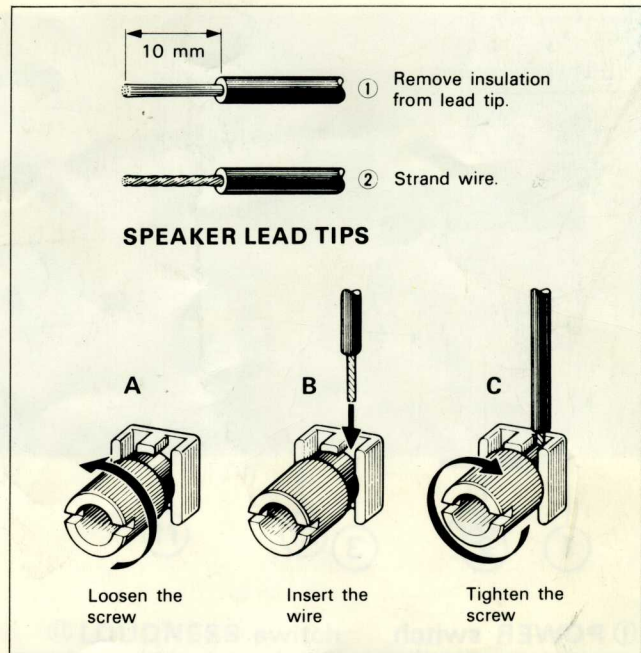

TAPE DECK CONNECTION

Recording

A tape deck can be connected for recording as follows: the left channel input of the tape deck to "LEFT" of the TAPE A REC jack, the right channel input of the tape deck to "RIGHT" of the TAPE A REC jack.

Playback

A tape deck can be connected for playback as follows: the left channel output of the tape deck to "LEFT" of the TAPE A PLAY jack, right channel output of the tape deck to "RIGHT" of the TAPE A PLAY jack.

If an additional tape deck is used and two tape decks are operated simultaneously, the same connections must be provided for the TAPE B jacks.

DIN CONNECTOR (REC/PLAY CONNECTOR)

If your tape deck is equipped with a DIN connector, connect it to the TAPE B REC/PLAY connector with a DIN connecting cord. A DIN connector enables recording and playback with this single cord.

Notes:

- 1) The REC/PLAY connector corresponds to the TAPE B REC and TAPE B PLAY jacks – the signal must be controlled with TAPE switch on the front panel.
- 2) When a DIN cord is used for connecting to the tape deck, the TAPE B PLAY and TAPE B REC jacks should not be used.

CONTROLS AND FUNCTIONS

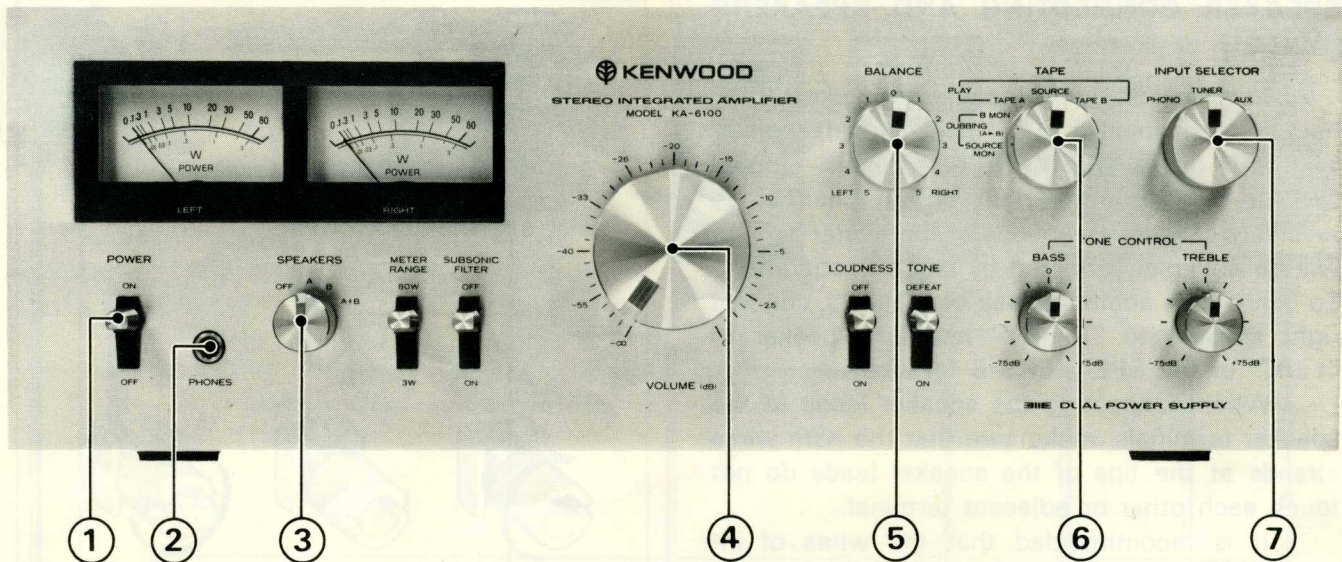

① POWER switch

ON..... The unit is turned on.
OFF..... The unit is turned off.

② PHONES jack

Plug a stereo headphones into this jack. For private listening through headphones, set the SPEAKERS switch to "OFF"

③ SPEAKERS switch

OFF..... All speakers are silenced for private headphones listening.
A..... Speakers connected to the SPEAKERS A terminals on the rear panel are activated.
B..... Speakers connected to the SPEAKERS B terminals are activated.
A + B..... Two pairs of speakers connected to the SPEAKERS A and B terminals are simultaneously activated.

④ VOLUME control

This control performs simultaneous adjustment of volumes in both channels (right and left). Set it to your own most satisfactory listening level.

⑤ BALANCE control

This control adjusts unequal volume from any program source in right and left channels. The left channel is accentuated when this control is turned from the center "0" toward the left side and conversely.

⑥ TAPE switch

PLAY:
SOURCE – The source signal is heard.

TAPE A – It is available to monitor a recording or for playback on a tape deck connected to the TAPE A jacks.

Sound recorded on the tape is heard.

TAPE B – It is available to monitor a recording or for playback on a tape deck connected to the TAPE B jacks.

Sound recorded on the tape is heard.

Note:

Except for tape playback and for monitoring a recording, make sure it is in the "SOURCE" position.

DUBBING (A ► B):

B MON – It is available to dub from a tape deck connected to the TAPE A jacks into a tape deck connected to the TAPE B jacks. The recording condition of the tape deck B can be monitored.

SOURCE MON – Parallel with the tape dub operation (A ► B), this position makes it possible to reproduce simultaneously from the speakers other program sources selected by the INPUT SELECTOR switch such as an FM broadcast or phono disc reproduction.

⑦ INPUT SELECTOR switch

PHONO..... The turntable is available if connected to the PHONO input jacks on the rear panel.

TUNER..... The tuner is available if connected to the TUNER input jacks on the rear panel.

AUX..... Source connected to the AUX jack is available.

CONTROLS AND FUNCTIONS

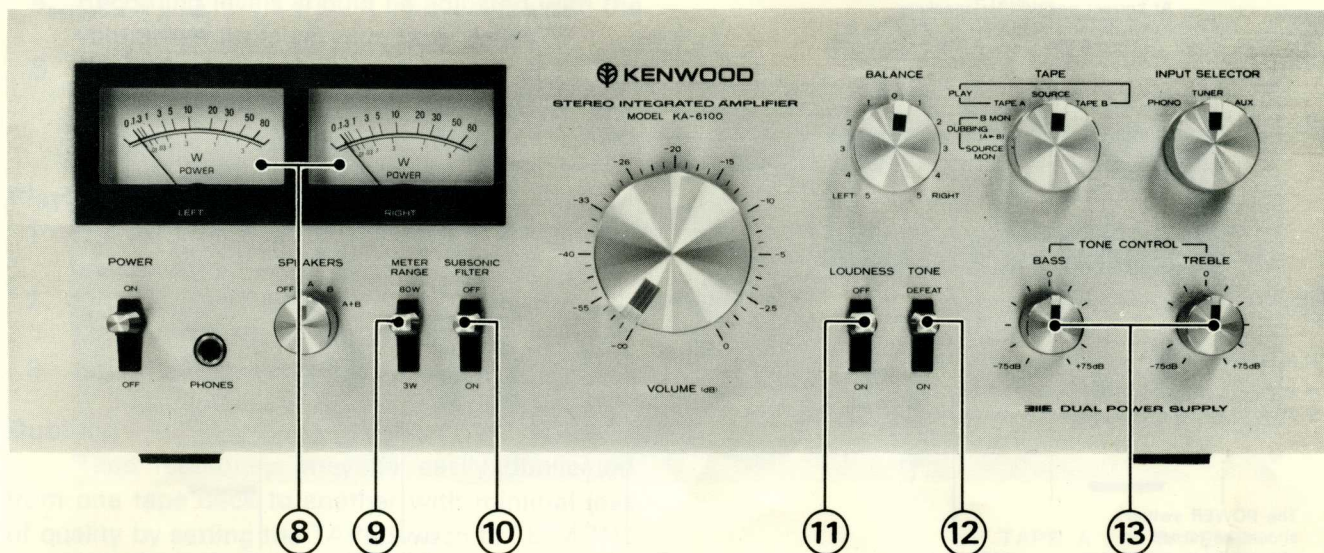

⑧ POWER meters

These meters indicate the strength of the output volume level. They can be read directly in watts from 0.01 to 80 watts on the scale for speaker impedance of 8 ohms (controlled by the Meter Range switch). When speaker impedance is 4 ohms, output power is twice the figure on the scale. If speaker impedance is 16 ohms, output power is then half the scale amount. However, musical signals actually assume complex wave forms with much variations, and the indicated power corresponds approximately to the mean value of these wave forms.

⑨ METER RANGE switch

This switch controls the sensitivity of both the left and right channel output level meters. Use the switch suitable for your listening requirements.

Note:

To protect the meters from overswing, make it a practice to move up the switch to the "80W" first, and advance successively to "3W" when no deflection can be observed.

⑩ SUBSONIC FILTER switch

Frequencies below 18 Hz are attenuated by 6 dB/octave. Although such subsonic frequencies are inaudible to the human ear, they can cause intermodulation distortions and even damage to the speakers. It is recommendable to set the lever "ON" at all times, even if no record rumble etc. are heard. "OFF" position is no attenuation of subsonic frequencies.

⑪ LOUDNESS switch

This switch boosts bass response to compensate for the human ear's lack of response to those frequencies at low volume levels. This switch should be set to "OFF" when listening at normal and high levels.

⑫ TONE switch

In position "DEFEAT", the bass and treble control do not function. By switching between "DEFEAT" and "ON", this enables you making frequency response measurements of phono cartridges, speakers and the acoustic conditions of the room.

⑬ TONE controls

These controls are for adjusting the bass and treble response. They are a click step type control by approximately 1.5 dB. Turning the controls clockwise increase bass and treble response and counterclockwise decrease bass and treble response. Bass and treble controls do not function when the TONE switch is set to "DEFEAT".

OPERATING INSTRUCTIONS

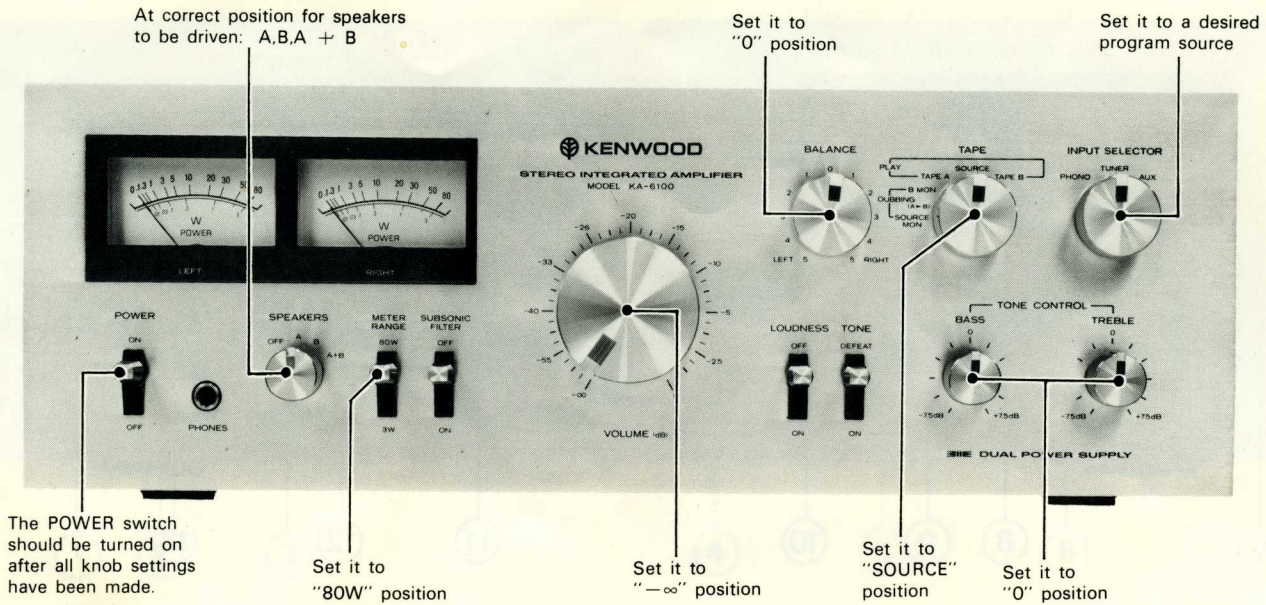

Prior to switching power ON.

RADIO RECEPTION

1. Set the INPUT SELECTOR switch to "TUNER".
2. Operate the tuner as usual.
3. Use the VOLUME, BASS, TREBLE, BALANCE, etc. controls to adjust sound as desired and to match the acoustic conditions of your room.

TURNTABLE OPERATION

1. Set the INPUT SELECTOR switch to "PHONO".
2. Operate the turntable.
3. Use the VOLUME, TREBLE, BALANCE, etc., controls to obtain the desired listening volume and tonal quality.

TAPE DECK OPERATION

Tape Monitoring

If you use the amplifier with 3-head type tape decks, you can check the sound quality of the recording that is being made by momentarily comparing the recorded signal with the source signal as follows: Set the TAPE switch to "TAPE A" (or "TAPE B") to monitor the recorded sound. Set the TAPE switch to "SOURCE" to monitor the source signal before it is recorded.

When Recording with One Tape Deck

Connect the tape deck to either TAPE A jacks or TAPE B jacks on the rear panel.

Recording

1. Set the INPUT SELECTOR switch to the desired program source; PHONO, TUNER or AUX.
2. Set the TAPE switch to "TAPE A" or "TAPE B" whichever side the tape deck is connected.
3. Recording level should be adjusted with the volume control of your tape deck.
4. Recording is not affected by the VOLUME, BASS, TREBLE, LOUDNESS, etc., controls of the unit.

When Recording with Two Tape Decks

Connect one tape deck to the TAPE A jacks and the other to the TAPE B jacks on the rear panel.

Recording

1. Set the INPUT SELECTOR switch to the desired program source; PHONO, TUNER or AUX.
2. Set the TAPE switch to "SOURCE".
3. Recordings can now be made into both tape decks simultaneously.

To monitor these recordings, use the TAPE switch as follows: Set it to "TAPE B" to monitor the recording being made in the tape deck connected to TAPE B jacks.

Note:

In case of recording with two tape decks, a source signal can not be recorded in the tape deck connected to "TAPE B" jacks when the TAPE switch is set to "TAPE A".

Therefore, be sure to set the TAPE switch to "SOURCE" or "TAPE B" only.

OPERATING INSTRUCTIONS

- Recording levels should be adjusted with the volume controls of your tape decks.
- Recording is not affected by the VOLUME, BASS, TREBLE, FILTER, LOUDNESS, etc., controls of the unit.

Playback

- The INPUT SELECTOR switch can be in any position.
- Set the TAPE switch to the corresponding position "TAPE A" or "TAPE B".
- Adjust volume and tonal quality.

Dubbing

Tape recordings may be easily duplicated from one tape deck to another with minimal loss of quality by setting the TAPE switch to "B MON" or "SOURCE MON" as follows:

- The INPUT SELECTOR switch can be in any position.
- Set the TAPE switch to "B MON" when it is desired to copy recorded material on the tape deck A for recording on the tape deck B. The recording can be monitored. In addition, "SOURCE MON" position can be done at the same time that a different source signal such as an FM broadcast or phono disc is being reproduced through the speakers.

Note:

Be sure to set the TAPE switch to "B MON" or "SOURCE MON" only.

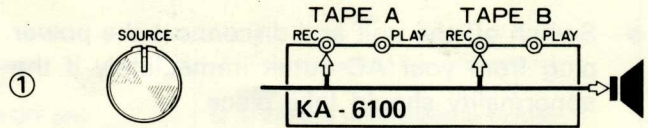
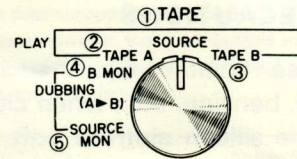

Tape Recording : The input signal selected by the INPUT SELECTOR switch is always present at a fixed level at the TAPE A and TAPE B REC jacks.

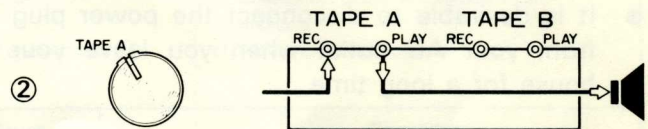

Tape Playback : Playback signal enters TAPE A PLAY jacks, and is heard from the speakers.

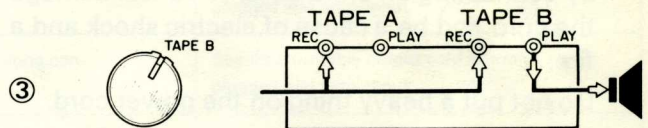

Tape Playback : Playback signal enters TAPE B PLAY jacks, and is heard from the speakers.

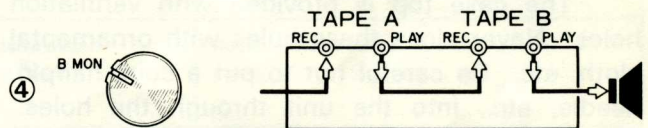

Dubbing : Playback signal from tape deck A enters via TAPE A PLAY jacks, passes through TAPE switch B MON, and is recorded by tape deck B.

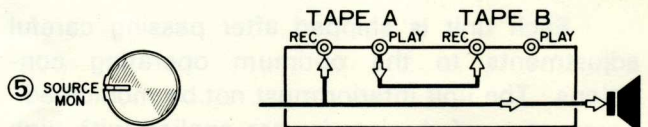

Dubbing : Playback signal from tape deck A enters via TAPE A PLAY jacks, passes through TAPE switch SOURCE MON, and is recorded by tape deck B. In addition, this position makes it possible that a different source signal such as an FM broadcast or phono disc is being reproduced through the speakers.

MAINTENANCE

CLEANING PRECAUTIONS

Do not use volatile liquid such alcohol, thinner, gasoline, benzine, etc., when cleaning the unit surface. Use silicon cloth or soft dry cloth.

POWER PLUG

- Switch off the unit and disconnect the power plug from your AC outlet immediately if the abnormality should take place.
- When you connect or disconnect the power plug from your AC outlet, never do it with wet hands to avoid unexpected accident from electric shock. Besides, do it by holding the power plug itself, not the power cord.
- It is desirable to disconnect the power plug from your AC outlet when you leave your house for a long time.

POWER CORD

- The power cord must not be pulled strongly, nor bent forcibly, nor scratched, nor extended by connecting an extra cord. This will damage the cord and be a cause of electric shock and a fire.
- Do not put a heavy thing on the power cord.

PREVENTION OF INTRUSION OF METALLIC SUBSTANCE IN UNITS

The case top is provided with ventilation holes. Never close these holes with ornamental cloth, etc. Be careful not to put a coin, hairpin, needle, etc., into the unit through the holes. Otherwise, it may be a case of malfunction and electric shock. Such trouble is often caused by infants.

PREVENTION OF MODIFICATION

Each unit is shipped after passing careful adjustments to the optimum operating conditions. The unit interior must not be modified. Some parts of the interior are applied with high voltage. Never dismantle the case and touch the internal parts. Only the qualified servicemen are in charge of check-in the interiors.

PROTECTION OF SPEAKERS SYSTEM

Lower the sound volume when switching the amplifier on or changing over the program source to another. You should make it a rule to move the volume control knob to a low sound level before you turn the POWER switch on. Sudden feeding of a large input power may damage the speaker systems. If you keep such a habit, the speaker systems can be protected against the attack of violent noise occurring when a stylus is put on a disc or broadcasting station is selected.

ACOUSTIC FEEDBACK

Occasionally a disturbing howling sound caused by acoustic feedback, may be heard. This is generally caused by the relative positions of the turntable and speaker enclosures. The sound pressure radiated from the speaker box surrounds and vibrates the turntable.

This vibration is picked up by the cartridge, sent to the unit as an electrical signal, and returned to the speaker. This again causes the speakers to radiate vibration which induces sympathetic vibrations in the turntable and cartridge. Sympathetic vibrations are reinforced with each repeating cycle and result in an undesirable sound called oscillation or "howling". To prevent it, keep your turntable away from your speakers. Also mounting your turntable on shock-absorbing pads may help.

BEFORE ASKING SERVICE

When the unit does not operate as desired, it is often considered to have a trouble. In most cases, however, this is attributable to improper connection or improper setting of switch and control. Re-check your unit before asking service, referring to the table below.

INDICATIONS

During AM, FM or Turntable	Probable Cause	Correction
No sound although AC is switched ON.	Poor AC plug connection.	Check plug contact.
No sound from LEFT and RIGHT.	a) Speaker cords disconnected. b) SPEAKERS switch set to OFF position. c) Volume Control (extreme left). d) TAPE switch at TAPE A or TAPE B position.	a) Check connections from amp. output to speakers. b) SPEAKERS switch should be switched to OFF only when using stereo headphones. c) Set to appropriate volume level. d) Always set to SOURCE except when using tape decks.
Sound only from one side.	a) Poor speaker cord connections. b) BALANCE control set to one extreme or other.	a) Check amp. output and speakers connections. b) Adjust BALANCE control.
During Record Playback Only	Probable Cause	Correction
Difference in volume level of radio and phono.	Difference in received signal and phono output levels.	Set to appropriate volume level.
No sound from LEFT and RIGHT, or sound only from one side.	Turntable output cord disconnected.	See that turntable output cord is firmly plugged into amp. input.
Loud hum drowns out sound.	Poor turntable output cord prong connections.	See that turntable output cord is firmly plugged into amp. input.
Sound audible but background hum occurs.	a) Turntable output cord picking up hum from AC cord. b) Turntable not grounded.	a) Keep turntable output cord away from AC cords. Choose cord paths which keep hum at a minimum. Reverse turntable AC plug connections. b) Connect ground wire to GND terminal.
Sound audible but continuous background buzz interferes.	TV signal picked up by Turntable output cord. Frequency occurs near TV transmitting antenna.	Route turntable cord so that hum is minimized.
Howling noise occurs when volume is raised or bass response is increased.	Speaker vibrations induce feedback in Pickup.	Increase distance between turntable and speakers. Choose speaker locations carefully. Remember, loose flooring induces howling.

SPECIFICATIONS

Power Output

50 watts* per channel minimum RMS, both channels driven, at 8 ohms from 20 Hz to 20,000 Hz with no more than 0.03% total harmonic distortion.

Both Channels Driven 50 + 50 watts 8 ohms at 1,000 Hz
70 + 70 watts 4 ohms at 1,000 Hz

Dynamic Power Output 230 watts 4 ohms

Total Harmonic Distortion
(20 Hz to 20,000 Hz)

AUX input to SPEAKER

output 0.03% from 250 mW to 50W

PHONO input to SPEAKER

output 0.03% at rated power with
VOLUME -20 dB

Intermodulation Distortion 0.02% at rated power into 8 ohms

(60 Hz : 7 kHz = 4 : 1) 0.02% at 1 watt into 8 ohms

Power Bandwidth 5 Hz to 30,000 Hz

Damping Factor 50 at 8 ohms

Speaker Impedance Accept 4 ohms to 16 ohms

Input Sensitivity/Impedance

Phono 2.5 mV/50k ohms

Tuner 150 mV/50k ohms

AUX 150 mV/50k ohms

Tape A, B 150 mV/50k ohms

Signal to Noise Ratio (IHF. A)

Phono 86 dB for 2.5 mV input

92 dB for 5.0 mV input

98 dB for 10 mV input

Tuner 106 dB for 150 mV input

AUX 106 dB for 150 mV input

Tape A, B 106 dB for 150 mV input

Maximum Input Level for

Phono 230 mV (RMS), T.H.D. 0.03% at 1,000 Hz

Output Level/Impedance

Tape REC (Pin) 150 mV/450 ohms

(DIN) 30 mV/80k ohms

Frequency Response

Phono RIAA standard curve ± 0.3 dB

AUX and Tape 10 Hz to 50,000 Hz $+0$ dB, -1 dB

Tone Control

Bass ± 7.5 dB at 100 Hz

Treble ± 7.5 dB at 10,000 Hz

Loudness Control $+8$ dB at 100 Hz

(at -30 dB VOLUME Level)

Subsonic Filter 18 Hz, 6 dB/oct

GENERAL

Power Consumption 420 watts at full power

A.C. Outlet Switched 2, Unswitched 1

Dimensions:

without cabinet W 16-15/16" (430 mm)

H 5-7/8" (149 mm)

D 14-11/32" (364 mm)

with cabinet W 17-29/32" (455 mm)

H 7-1/32" (179 mm)

D 15-3/16" (385 mm)

Weight:

without cabinet Net: 21.6 lbs (9.8 kg)

Gross: 24.6 lbs (11.2 kg)

with cabinet Net: 24.9 lbs (11.3 kg)

Gross: 27.9 lbs (12.7 kg)

* Measured pursuant to Federal Trade Commission's Trade Regulation rule on Power Output Claims for Amplifier in U.S.A.

Note:

Kenwood follows a policy of continuous advancements in development. For this reason specifications may be changed without notice.

BLOCK DIAGRAM

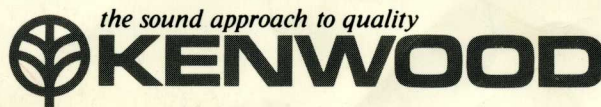
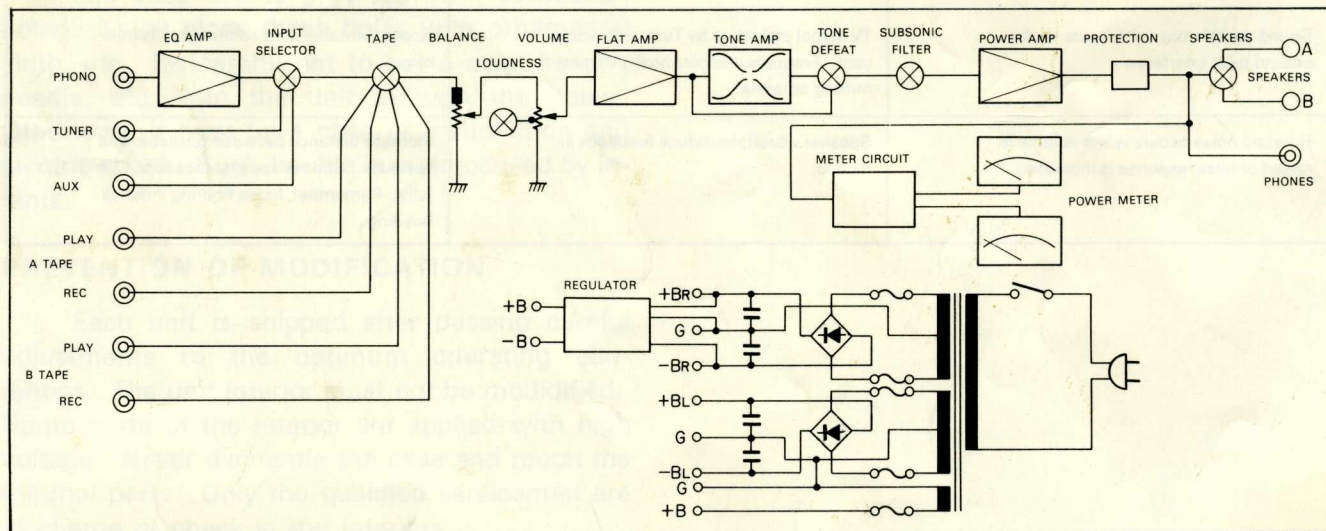

PRINTED IN JAPAN B50-1695-00 (KUSXWL) (G)

45/847 67890N/848 D12345/949 67890N/950 D12345/051