

Service Manual

THE FISHER.



400

CHASSIS SERIAL NUMBERS
BEGINNING 20000

\$1.00

FISHER RADIO CORPORATION • LONG ISLAND CITY 1 • NEW YORK

TUBE LAYOUT • RECEIVER

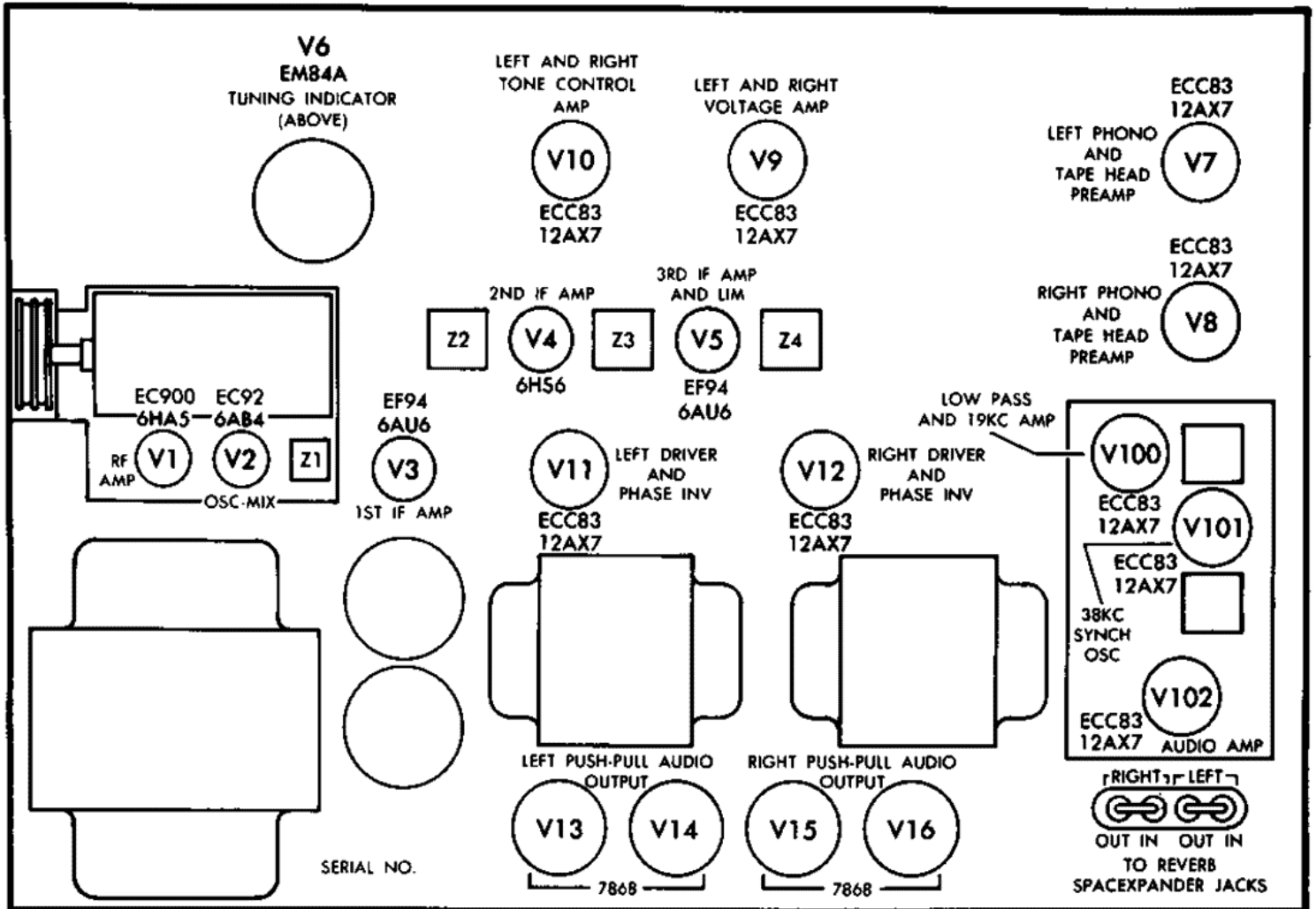

NOTE: IMPEDANCE SELECTOR SHOWN IN 16-OHM CONNECTION

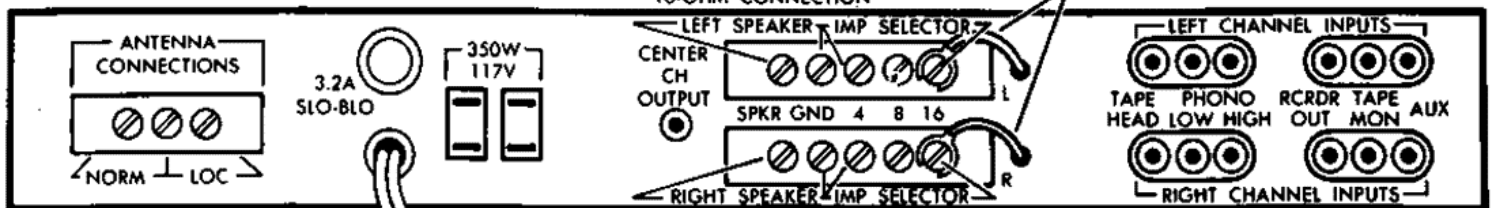

DIAL STRINGING PROCEDURE

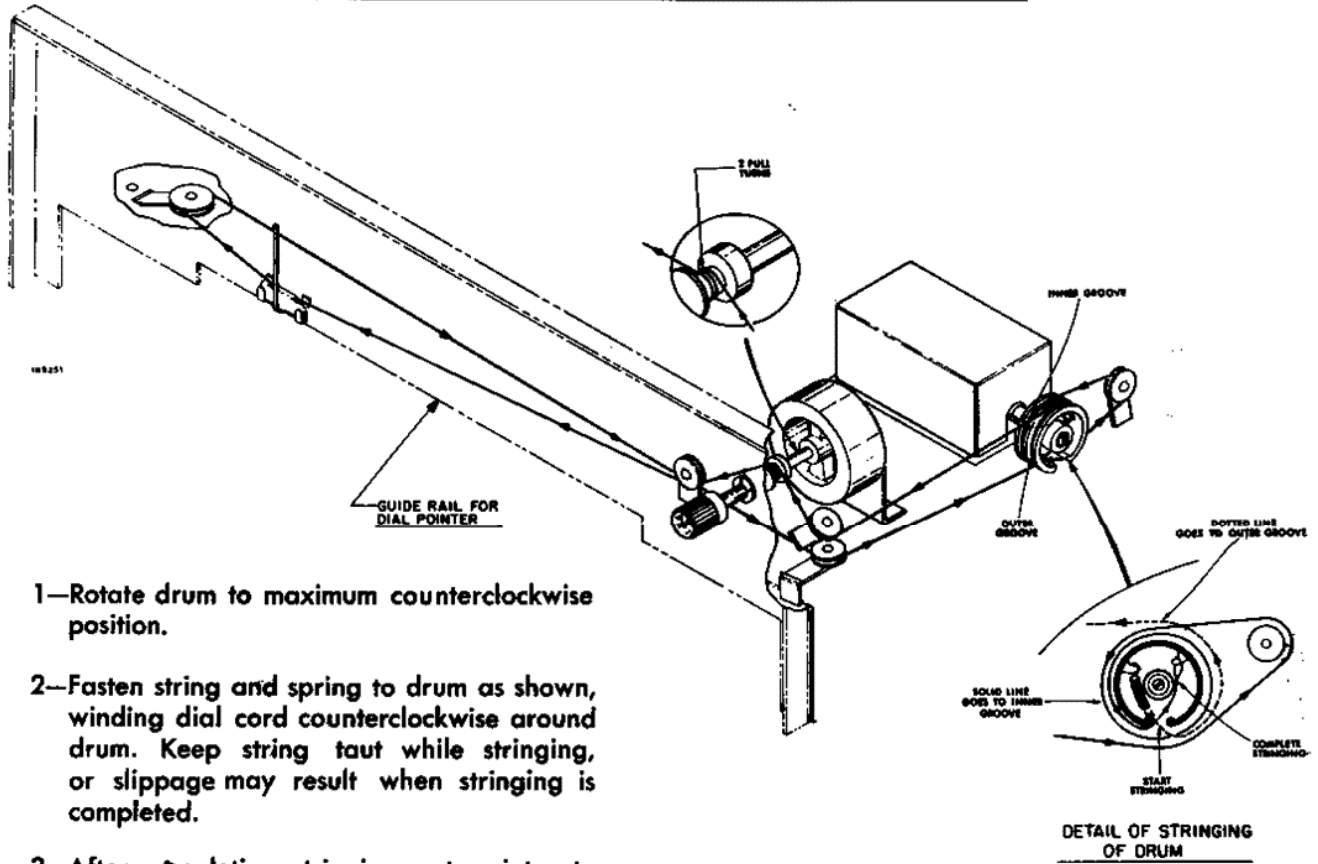

FISHER RADIO CORPORATION • NEW YORK

PARTS DESCRIPTION LIST

CAPACITORS

10% tolerance for all fixed capacitors, unless otherwise noted or marked GMV (guaranteed minimum value). All capacitors not marked uf are pF (puf).

Symbol	Description	Part No.
C1, 2	Ceramic, 100, GMV, N1500, 1000V	C50070-5
C3	Ceramic, 21, 5%, N750, 1000V	C50070-32
C4	Ceramic, 8, 5%, NPO, 1000V	C50070-45
C5	Ceramic Trimmer	C662-123
C6	Ceramic, 1000, GMV, 500V	C50089-2
C7	FM Variable	C966-109-1
C8	Ceramic, 1000, GMV, 500V	C50089-2
C9	Ceramic, 39, N1500, 1000V	C50072-17
C10, 11	Ceramic, .01uf, 20%, 500V	C50089-3
C12	Ceramic, 24, 5%, N150, 1000V	C50070-8
C13	Ceramic, 12, 5%, N080, 500V	CC20LJ120J5
C14	Ceramic, 13, 5%, NPO, 500V	CC20CJ130J5
C15, 16	Ceramic Trimmer	C662-123
C17	Ceramic, 8, 5%, NPO, 1000V	C50070-45
C19, 20	Mylar, .022uf, 250V	C50197-49
C21	Ceramic, 120, 5%, N1500, 1000V	C50070-44
C22	Ceramic, 1000, 1000V	C50072-3
C23, 24	Ceramic, Feedthru, 1000, GMV	C592-187
C25	Ceramic, 5000, +80 -20%, 500V	C50089-6
C26	Ceramic, 2700, 1000V	C50072-17
C27	Ceramic, 560, 1000V	C50072-14
C28	Ceramic, 5000, +80 -20%, 500V	C50089-6
C29, 30	Ceramic, 120, N1500, 1000V	C50070-9
C31	Ceramic, 24, 5%, N150, 1000V	C50070-8
C32	Ceramic, 18 N470, 1000V	C50070-13
C33, 34	Ceramic, 1000, 1000V	C50072-3
C35, 36	Ceramic, .02uf, 20%, 500V	C50089-5
C37	Ceramic, 5000, +80 -20%, 500V	C50089-6
C38	Ceramic, 2700, 1000V	C50072-17
C39, 40	Ceramic, 5000, +80 -20%, 500V	C50089-6
C41	Ceramic, 2700, 1000V	C50072-17
C42	Ceramic, .02uf, GMV, 1000V	C50071-6
C43	Ceramic, 5000, +80 -20%, 500V	C50089-6
C44	Ceramic, 330, 1000V	C50072-1
C45, 46	Ceramic, 100, 5%, N1500, 1000V	C50070-19
C47	Mylar, .1uf, 125V	C50435-7
C48, 49	Mylar, .047uf, 400V	C50197-30
C50, 51	Ceramic, 330, 1000V	C50072-1
C52	Ceramic, 1800, 1000V	C50072-8
C53, 54	Ceramic, 560, 1000V	C50072-14
C55	Electrolytic, 8uf, 50V	C629-138
C56, 57	Ceramic, 68, N2200, 1000V	C50070-12
C58, 59	Ceramic, .02uf, 20%, 500V	C50089-5
C60, 61	Ceramic, 330, 1000V	C50072-1
C62	Mylar, .047uf, 400V	C50197-30
C63	Mylar, .047uf, 250V	C50197-32
C64	Mylar, .047uf, 400V	C50197-30
C65	Mylar, .047uf, 250V	C50197-52
C66, 67	Ceramic, 18, N470, 1000V	C50070-13
C68, 69	Ceramic, .02uf, +80 -20%, 500V	C50089-4
C70, 71, 72, 73	Ceramic, 5000, +80 -20%, 500V	C50089-6
C74	Electrolytic, 100uf, 25V	C643-145
C75	Electrolytic, 4 Section: A—20uf, 300V B—40uf, 400V C—40uf, 450V D—40uf, 500V	C50180-49

C76	Electrolytic, 100uf, 300V	C50180-43
C77	Electrolytic, 3 Section: A—50uf, 250V B—50uf, 250V C—200uf, 300V	C50180-51
C78	Electrolytic, 2 Section: A—1000uf, 35V B—1000uf, 35V	C50180-38
C79	Ceramic, Feedthru, 1000, GMV	C592-187
C80	Molded, .01uf, 20%, 600V	C2747
C81, 82	Ceramic, 330, 1000V	C50072-1
C83	Molded, .01uf, 20%, 600V	C2747

RESISTORS & POTENTIOMETERS

In ohms, 5% tolerance, 1/8 watt unless otherwise noted. K=Kilohms, M=Megohms.

Symbol	Description	Part No.
R1	Composition, 270, 10%, 1/2 W	RC20BF271K
R2	Composition, 100K, 10%, 1/2 W	RC20BF104K
R3, 4	Dep. Carbon, 220K	R12DC224J
R5, 6	Dep. Carbon, 150K	R12DC154J
R7, 8	Dep. Carbon, 68K	R12DC683J
R9, 10	Dep. Carbon, 100K	R12DC104J
R11, 12	Dep. Carbon, 10	R12DC100J
R13, 14	Dep. Carbon, 10K	R12DC103J
R15	Dep. Carbon, 1.2K	R12DC122J
R16, 17	Glass, 330K, 1W	R30G334J
R18, 19	Dep. Carbon, 4.7M, 1/2 W	R33DC475J
R20	Dep. Carbon, 220K	R12DC224J
R21, 22	Dep. Carbon, 220K, 1/2 W	R33DC224J
R23, 24	Dep. Carbon, 330K	R12DC154J
R25	Dep. Carbon, 150K	R12DC102J
R26	Dep. Carbon, 1K	R12DC102J
R27	Composition, 4.7K, 10%, 1/2 W	RC20BF472K
R28	Composition, 3.9K, 10%, 1W	R30BF392K
R29	Composition, 150, 10%, 1/2 W	RC20BF151K
R30	Composition, 27K, 10%, 1/2 W	RC20BF273K
R31	Composition, 1K, 10%, 1/2 W	RC20BF102K
R32, 33	Dep. Carbon, 330K	R12DC334J
R34, 35	Dep. Carbon, 470K	R12DC474J
R36, 37	Dep. Carbon, 1.5M, 1/2 W	R33DC155J
R38, 39	Dep. Carbon, 2.7M, 1/2 W	R33DC275J
R40, 41	Dep. Carbon, 1K	R12DC102J
R42, 43	Dep. Carbon, 120K, 1/2 W	R33DC124J
R44	Composition, 150, 10%, 1/2 W	RC20BF151K
R45	Composition, 47K, 10%, 1/2 W	RC20BF473K
R46	Composition, 1K, 10%, 1/2 W	RC20BF102K
R47, 48	Dep. Carbon, 680K	R12DC684J
R49	Composition, 10M, 10%, 1/2 W	RC20BF106K
R50	Potentiometer, 500K, Dual Treble	R50160-136-1
R51	Potentiometer, 500K, Dual Bass	R50160-136-2
R52	Composition, 1K, 10%, 1/2 W	RC20BF102K
R53	Composition, 56K, 10%, 1/2 W	RC20BF563K
R54	Composition, 3.9M, 10%, 1/2 W	RC20BF395K
R55	Composition, 470K, 10%, 1/2 W	RC20BF474K
R56, 57	Dep. Carbon, 1K	R12DC102J
R58	Composition, 270, 1/2 W	RC20BF271J
R59, 60	Dep. Carbon, 120K, 1/2 W	R33DC124J
R61, 62	Dep. Carbon, 220K	R12DC224J
R63	Dep. Carbon, 47K	R12DC473J
R64, 65	Dep. Carbon, 2.7M, 1/2 W	R33DC275J
R66	Composition, 1.5K, 1/2 W	RC20BF152J

PARTS DESCRIPTION LIST

R67	Composition, 1K, 1/2 W	RC208F102J
R68, 69	Dep. Carbon, 470K	R12DC474J
R70	Dep. Carbon, 15K	R12DC153J
R71	Potentiometer, 500K, Balance	R50160-135
R72	Dep. Carbon, 330K	R12DC334J
R73	Dep. Carbon, 150K	R12DC154J
R74, 75	Dep. Carbon, 22K	R12DC223J
R76	Potentiometer, 500K, Dual Volume	R50160-104
R77, 78	Dep. Carbon, 390K, 1/2 W	R33DC394J
R79, 80	Dep. Carbon, 1.2K	R12DC122J
R81, 82	Dep. Carbon, 220	R12DC221J
R83, 84	Potentiometer, 500K	R50150-6
R85	Composition, 100K, 10%, 1/2 W	RC208F104K
R86, 87	Dep. Carbon, 47K, 1/2 W	R33DC473J
R88, 89	Dep. Carbon, 120K, 1/2 W	R33DC124J
R90, 91	Dep. Carbon, 3.9K	R12DC392J
R92, 93	Composition, 220, 10%, 1/2 W	RC208F221K
R94	Composition, 10K, 1/2 W	RC208F103J
R95	Composition, 22K, 10%, 1/2 W	RC208F223K
R96, 97	Dep. Carbon, 150K, 1/2 W	R33DC154J
R98, 99,		
100, 101	Dep. Carbon, 330K	R12DC334J
R102	Composition, 5.6K, 1/2 W	RC208F562J
R103	Composition, 2.2K, 10%, 1W	RC308F222K
R104	Composition, 1.2K, 10%, 1W	RC308F122K
R105	Glass, 1.2K, 10%, 7W	RPG7W122K
R106, 107,		
108, 109	Dep. Carbon, 1K, 1/2 W	R33DC102J
R110, 111	Glass, 330, 10%, 3W	RPG3W331K
R112	Wirewound, 15, 10%, 5W	R719-106
R113	Dep. Carbon, 4.7K, 1/2 W	R33DC472J
R114, 115	Wirewound, 25, 10%, 5W	R688-117
R116, 117	Dep. Carbon, 2.2K, 1/2 W	R33DC222J
R118	Composition, 820K, 10%, 1/2 W	RC208F824K
R119, 120	Composition, 330, 10%, 1/2 W	RC208F331K
R121, 122	Dep. Carbon, 47K	R12DC473J
R123, 124	Dep. Carbon, 82K	R12DC823J
R125, 126	Glass, 2.7K, 1/2 W	R20G272J
R127	Dep. Carbon, 47K	R12DC473J

COILS, CHOKES & TRANSFORMERS

Symbol	Description	Part No.
L1	FM Antenna Coil	L966-113
L2	FM RF Coil	L1034-113
L3	FM Mixer Coil	L1034-112
L4	FM Oscillator Coil Assembly	AS1034-115
L5	Choke, 1.2 Microhenries	L50066-3
L6	Choke, .68 Microhenry	L50066-1
L7	Choke, 3.3 Microhenries	L50066-8
T1	Transformer, Output	T1020-116-1
T2	Transformer, Output	T1020-116-2
T3	Transformer, Power	T1020-124
Z1	FM IF Transformer	ZZ50210-20
Z2	FM IF Transformer	ZZ50210-39
Z3	FM Limiter Coil Assembly	L50210-6
Z4	FM Ratio Detector Assembly	ZZ50210-9

MISCELLANEOUS

Symbol	Description	Part No.
CR1, 2	Silicon Diode	SR50411-1
CR3	Selenium Rectifier Bridge	SR50253-1
F1	Fuse, 3,2 Amp., Slo-Blo	F3319
I1, 2	Lamp, Dial	I50441-4
J20	Jack, Earphone	J846-120-1
PC1, 2	Printed Circuit, Phono Tape Equalization	PC50187-3
PC3, 4	Printed Circuit, Tone Control	PC50187-9
PC5, 6	Printed Circuit, High Filter	PC50187-2
S1	Switch, Selector	S1020-119
S2, 3, 4, 5	Switch, Slide	S50200-5
S6	Switch, Power	Part of R76
—	Dress Panel	AS1020-108
—	FM Dipole Assembly	AS50227-1
—	Knob, Dummy Dual	E50324
—	Knob, Dual Front	E50323
—	Knob, Dual Rear	E50221
—	Knob, Tuning	E50324-1
—	Dial Glass	N1020-107
—	Fuse Holder	X563-151

PHASE INVERTER ADJUSTMENT

LEFT CHANNEL

- 1 — Connect a 16-ohm load between the Left Speaker terminals. Connect the Left Impedance Selector to the "16" terminal.
- 2 — Connect the input of the IM Distortion Analyzer across the 16-ohm load.
- 3 — Connect the IM Distortion Analyzer output to the Left AUX input jack.
- 4 — Set the Selector switch to AUX and adjust the Analyzer for 14 volts across the 16-ohm load.
- 5 — Adjust the Left Phase Inverter Adjust control for minimum IM distortion.

RIGHT CHANNEL

- 1 — Connect a 16-ohm load between the Right Speaker terminals. Connect the Right Impedance Selector to the "16" terminal.
- 2 — Connect the input of the IM Distortion Analyzer across the 16-ohm load.
- 3 — Connect the IM Distortion Analyzer output to the Right AUX input jack.
- 4 — Set the Selector switch to AUX and adjust the Analyzer for 14 volts across the 16-ohm load.
- 5 — Adjust the Right Phase Inverter Adjust control for minimum IM distortion.

ALIGNMENT INSTRUCTIONS

Read These Instructions With Extreme Care Before Attempting Alignment.

- CHASSIS: 1** — For the entire alignment procedure, set the Selector Switch to the MONO position.
- 2** — Turn the Tuning knob maximum counterclockwise. (Dial pointer should line up with calibration mark at the beginning of the dial. Reset the dial pointer if necessary.)
- 3** — Allow the Receiver and test equipment at least 15 minutes warm-up time. Adjust the line voltage for 117 volts AC 50-60 cps. Use fully insulated tools: a small screw-driver for trimmer capacitors C16, C15 and C5, a K-Tran tool for Z1, Z2 and a hex tool for all Z3, Z4, L4, L3, L2 and L1.

STEP	DIAL	SIGNAL GENERATOR			DC VTVM	ADJUST	INDICATION
		GENERATOR COUPLING	FREQ.	MOD.			
1	Set dial pointer for extreme C.C.W. position.	Ungrounded tube shield of V2	10.7 MC	None	Test Point 3	Z1, Z2, Z3, Z4 top and bottom	Maximum negative voltage (below 20 volts)
2		Ungrounded tube shield of V2	10.7 MC	None	Hot lead of DC VTVM to Test point 4. Ground lead of DC VTVM to junction of two series connected resistors (47K), wired between Test point 3 and ground.	Z5 top	Zero indication on zero center dial.
3	90 MC	Two 120 ohm carbon resistors in series with generator leads to the Normal antenna terminals.	90 MC	± 22.5 KC deviation at 400 cps.	Through 100K resistor to Test Point 2	L4, L3 and L2	Adjust for maximum negative voltages and check for sine wave-form, with scope at Left or Right RCRDR output.
4	106 MC		106 MC	± 22.5 KC deviation at 400 cps.	Through 100K resistor to Test Point 2	C16, C15 and C5	
5	98 MC		98 MC	± 22.5 KC deviation at 400 cps.	Through 100K resistor to Test Point 2	L1	

NOTE: (Steps 1 and 2): Decrease signal generator output while aligning IF transformers so that the VTVM indicates not more than specified voltages. Repeat steps 4 and 5 to obtain proper dial calibration and maximum sensitivity.

SCHEMATIC DIAGRAM • RECEIVER

SWITCH POSITION					
POS. NO.	S1	S2	S3	S4	S5
	SELECTOR	TAPE	RFC	SWITCHING	SPREADER
	SWITCH	SWITCH	FILTER	SWITCH	SWITCH
1	TAPE HEAD	OFF	OFF	OFF	OFF
2	PHONO HEAD	ON	ON	ON	ON
3	PHONO STEREO				
4	FM STEREO				
5	FM STEREO FILTER				
6	FM BIAS				
7	ANT. SW				

ALL SWITCHES ARE SHOWN IN THE NO. 1 POSITION.

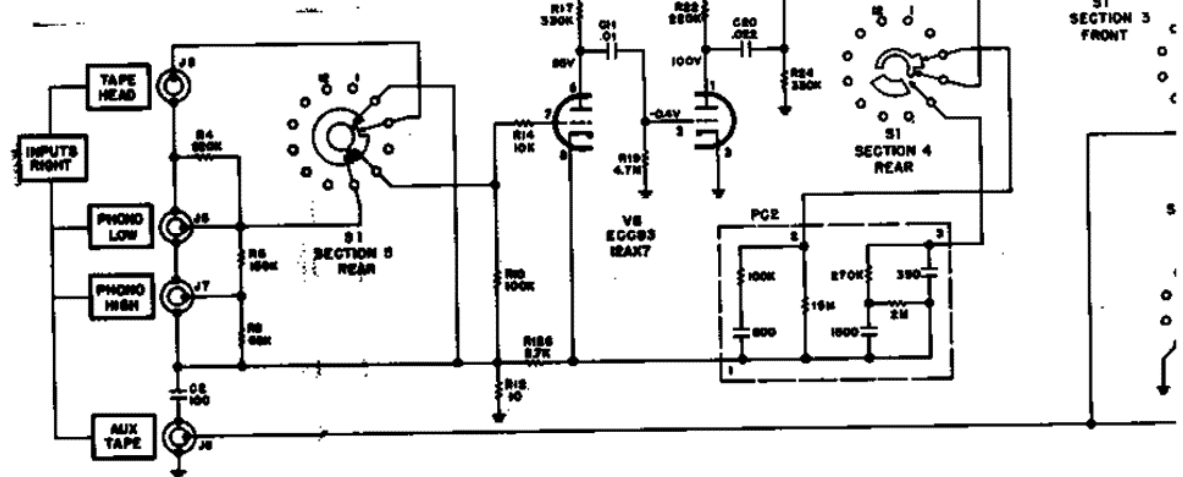
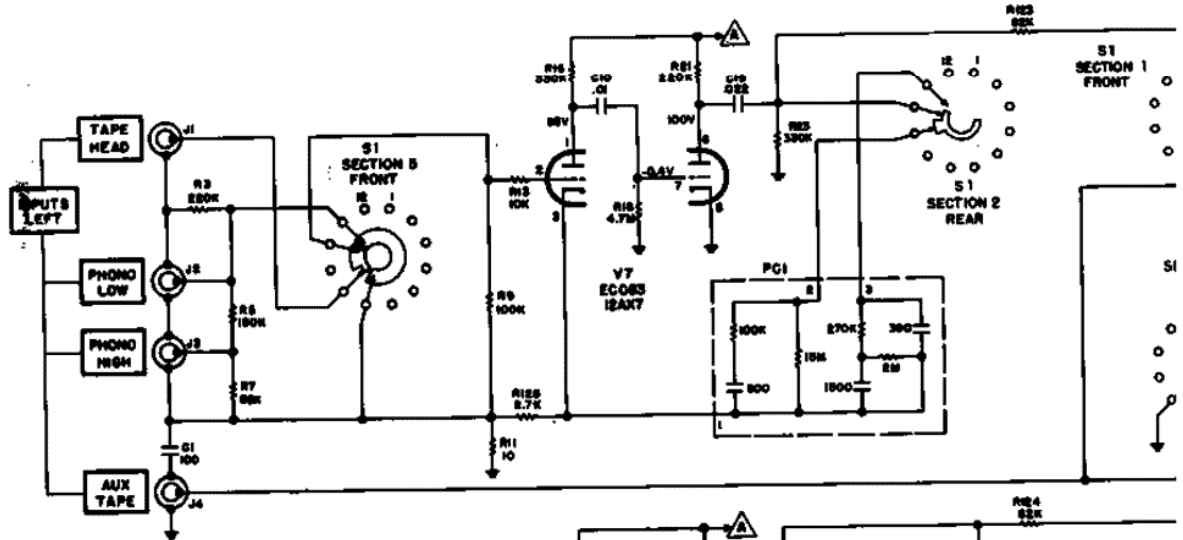
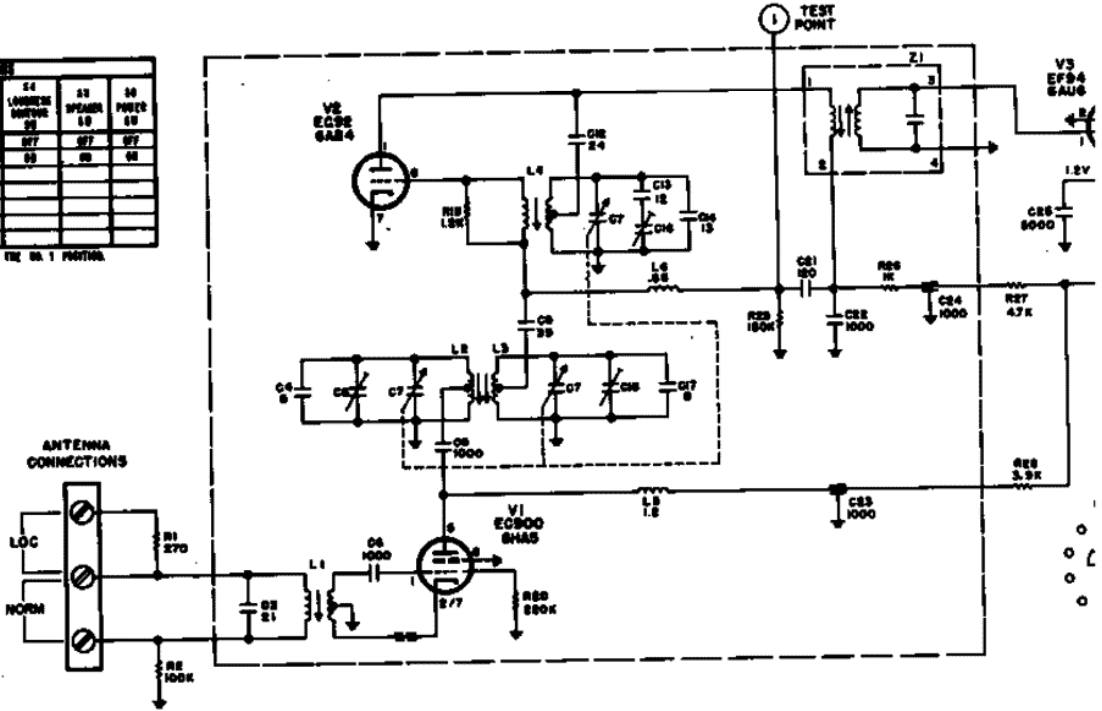

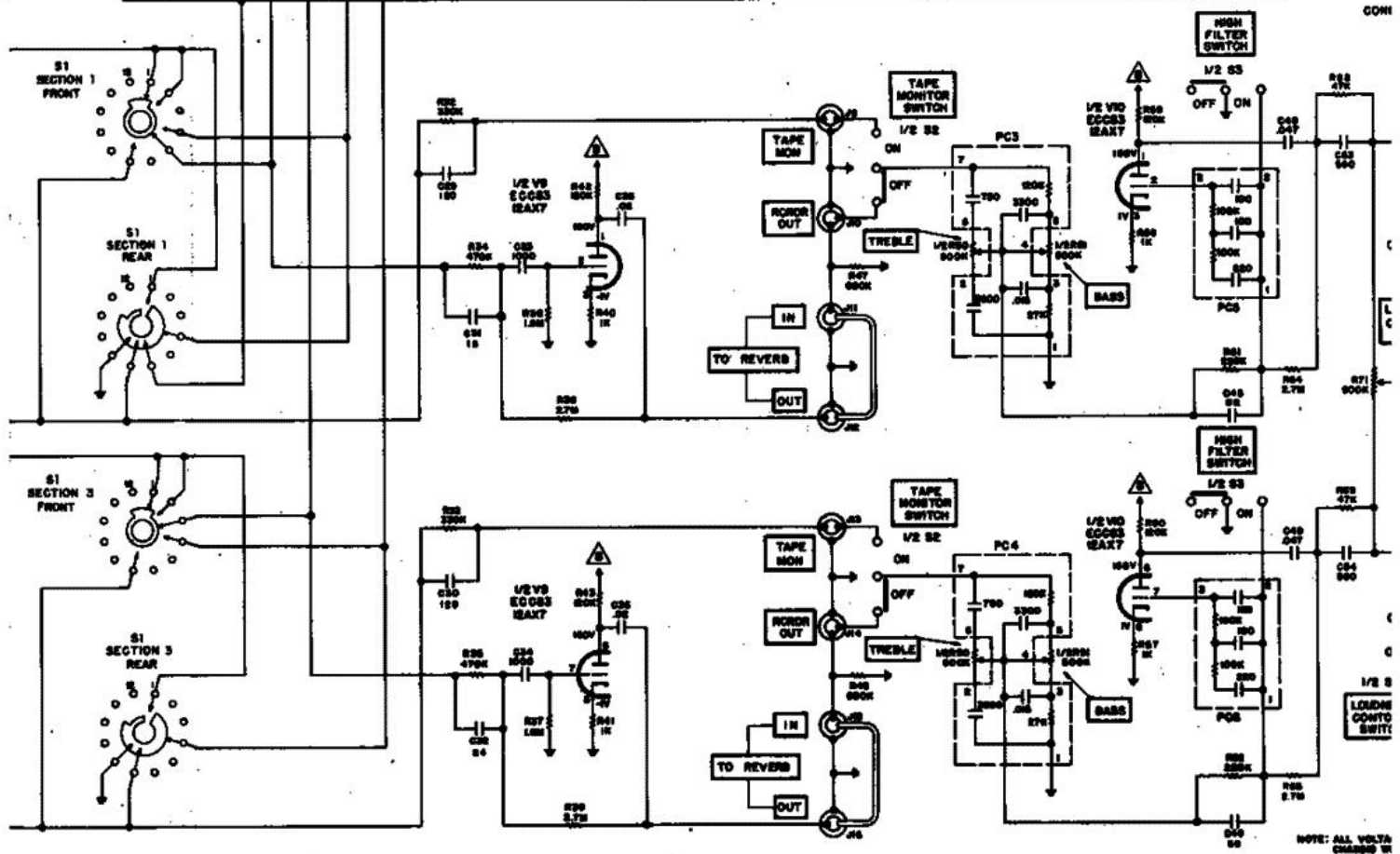
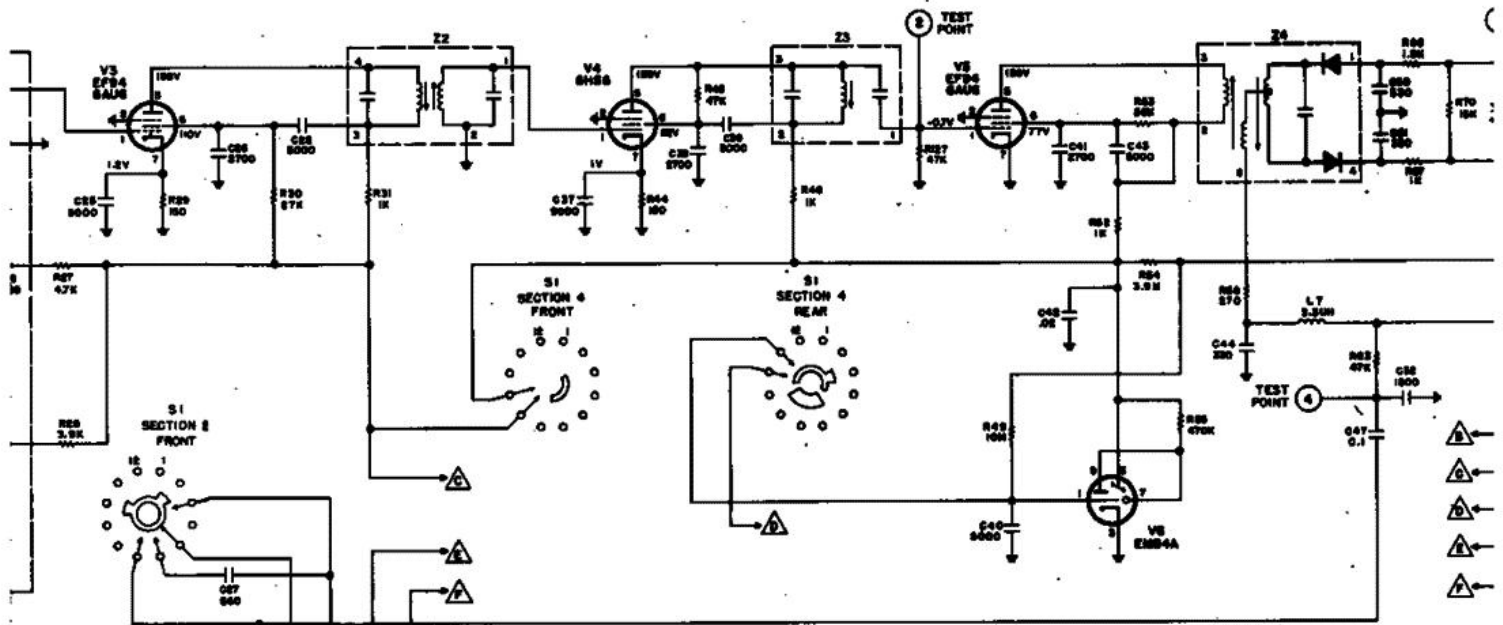

NOTE: ALL VOLTS
CHANGED IN

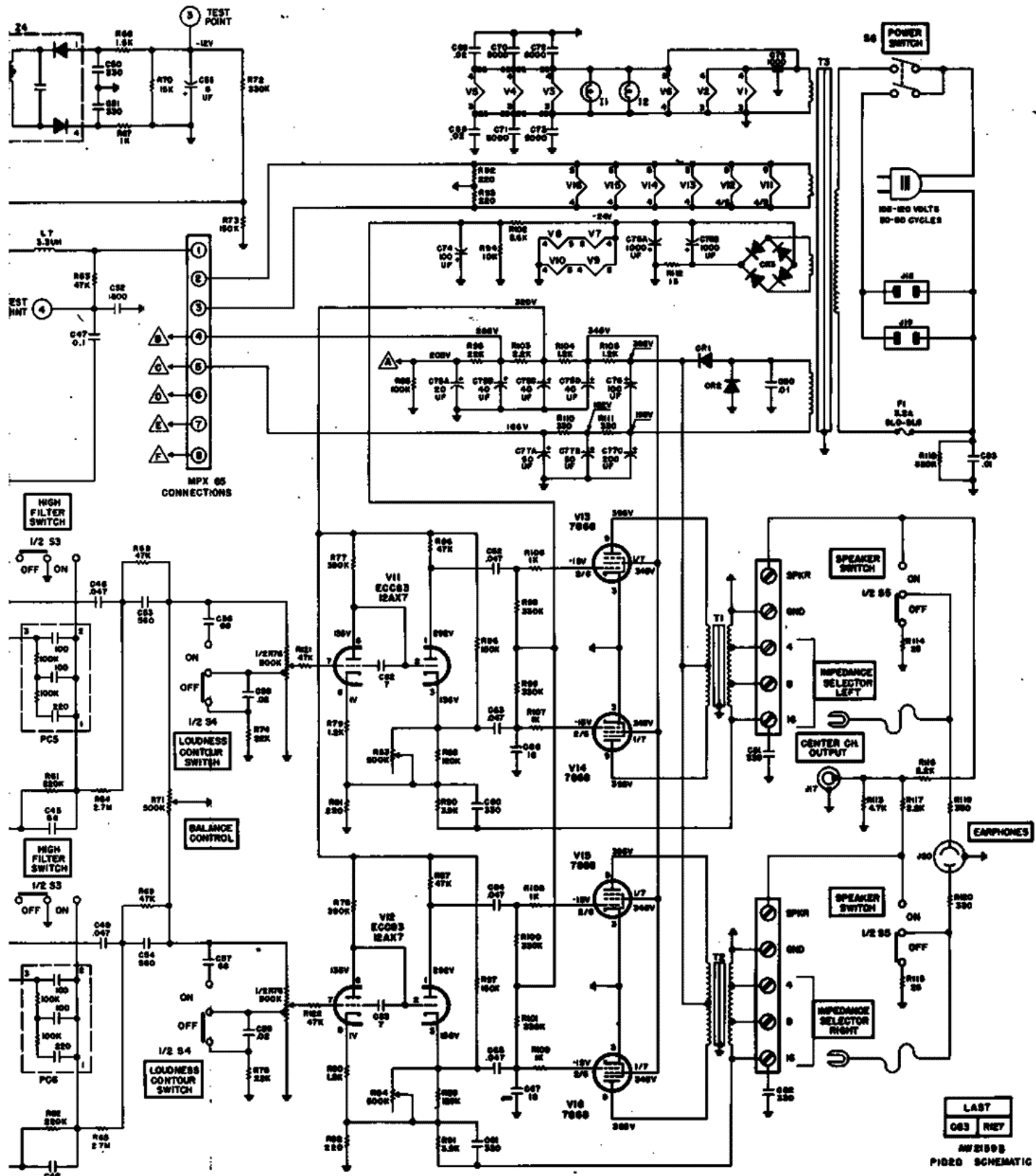

NOTE: ALL VOLTAGES ARE MEASURED AGAINST CHASSIS WITHOUT SIGNAL AT THE ANTENNA TERMINAL.

LAST
 063 R127
 AW 2159 B
 P1020 SCHEMATIC

ALIGNMENT INSTRUCTIONS • MULTIPLEX SECTION

STEPS	GENERATOR			INDICATOR	ALIGNMENT		
	CONNECTION	AUDIO FREQUENCY	RF MODULATION	TYPE & CONNECTION	ADJUST	INDICATION	NOTES
1	Audio oscillator connected to lug 1	80 KC—1 volt	None	AC VTVM to junction of C210 and R228	L100 (Use hex alignment tool)	Minimum voltage	
2	Multiplex generator audio output to lug 1 (See Note 1)	19 KC (± 5 cps) pilot tone, 100 mv	None	DC VTVM to T.S.P. 101	Z100 top and bottom (Use hex alignment tool)	Maximum voltage	1
3	Same as Step 2	19 KC pilot tone, 50 mv	None	Scope horiz. input to 19 KC output of gen.; vert. input to junction of C216 and R209. External sweep	Z101 (Use K-tron alignment tool)	Stable 2:1 Lissajous pattern. Disregard phase of pattern	1
4	Same as Step 2	19 KC	None	Same as Step 3	Vary generator 19 KC output from 50 to 200 mv	Lissajous pattern should remain stationary over the entire 150 mv range	1, 2
5	Same as Step 2	1000 cps on left (A) channel only, 1 volt rms (2.8 P-P)	None	AC VTVM and scope vert. input to channel A output lug. Internal sweep. DC VTVM to T.S.P. 101	Z100 top (Use hex tool)	Maximum indication on AC VTVM. Clean 1000 cps waveform on scope	1, 3
6	Same as Step 2	1000 cps on right (B) channel only, 1 volt rms (2.8 P-P)	None	Same as Step 5	MPX separation R215	Minimum reading on AC VTVM should be at least 33 db below reading obtained in Step 5	1
7	Same as Step 2	Same as Step 6	None	Move scope input and AC VTVM to channel B output lug	—	Note and record voltage reading on AC VTVM	1
8	Same as Step 2	1000 cps on left (A) channel only, 1 volt rms (2.8 P-P)	None	Same as Step 7	—	AC VTVM reading should be at least 33 db below reading observed in Step 7	1
9	Same as Step 2	8000 cps on right (B) channel only, 1 volt rms (2.8 P-P)	None	Same as Step 7	—	AC VTVM reading should be the same as observed in Step 7	1
10	Same as Step 2	8000 cps on left (A) channel only, 1 volt rms (2.8 P-P)	None	Same as Step 7	—	AC VTVM reading should be at least 18 db below reading observed in Step 9	1
11	Repeat Steps 9 and 10 with scope and AC VTVM connected to channel A output lug, but start with 8000 cps applied to left channel for first reading, then switch to right channel for second reading.						
12	Multiplex generator RF output to 300-ohm antenna terminals	1000 cps on left (A) channel only	100% (75 KC Dev.) No pre-emphasis	Move scope input and AC VTVM to channel A output lug	—	Note and record voltage reading on AC VTVM	4
13	Same as Step 12	1000 cps on right (B) channel only	Same as Step 12	Same as Step 12	R215	Minimum reading on AC VTVM should be at least 33 db below reading observed in Step 12	4
14	Same as Step 12	8000 cps on left (A) channel only	Same as Step 12	Same as Step 12	—	AC VTVM reading should be 10 db below reading observed in Step 12	4
15	Same as Step 12	8000 cps on right (B) channel only	Same as Step 12	Same as Step 12	—	AC VTVM reading should be 28 db below reading observed in Step 12	4

NOTE: The above procedure is based on the use of the FISHER Model 300 Multiplex Generator.

1 — In steps 2 through 11, the audio output of the Multiplex Generator should be connected to lug 1 of the multiplex sub-chassis through a 12,000 ohm, 1/2-watt, carbon resistor, and a 180 uuf capacitor should be connected between lug 1 and ground. The wiring from the MPX TEST jack on the main chassis to lug 1 must be disconnected during Steps 2 through 11.

2 — The vertical amplitude of the Lissajous pattern will increase slightly

as the generator output is increased. This is a normal occurrence.

3 — If DC VTVM reading falls below -9 volts when maximum reading is obtained on the AC VTVM, readjust bottom of Z100, then repeat Step 5. Repeat this procedure until maximum AC VTVM reading is obtained with DC VTVM reading greater than -9 volts.

4 — Tune the FISHER to the RF output frequency of the Multiplex Generator.

DESCRIPTION LIST • MULTIPLEX SECTION

100V	C50073-2	R201	Composition, 4.7K, 1/2 W	RC20BF472J	R222, 223	Dep. Carbon, 27K	R120C273J
	C50197-25	R202	Composition, 15K, 1/2 W	RC20BF153J	R224, 225	Dep. Carbon, 22K	R12DC223J
	C50332-6	R203	Composition, 10M, 10%, 1/2 W	RC20BF106K	R226, 227,		
	C50089-2	R204	Dep. Carbon, 1M	R12DC105J	228, 229,		
	C50089-5	R205	Dep. Carbon, 220K, 1/2 W	R33DC224J	230, 231	Dep. Carbon, 1M	R12DC105J
	C50183-5	R206	Dep. Carbon, 1.8M	R12DC185J			
	C50089-5	R207	Dep. Carbon, 1M	R12DC105J			
	C50197-52	R208	Dep. Carbon, 22K	R12DC223J			
	C50072-3	R209, 210,					
	C50072-5	211, 212	Dep. Carbon, 33K	R12DC333J			
		R213, 214	Dep. Carbon, 100K	R12DC104J			
RS		R215	Potentiometer, 50K, MPX Separation	R50150-4			
unless otherwise noted.		R216	Composition, 22M, 10%, 1/2 W	RC20BF226K			
	Part No.	R217, 218	Dep. Carbon, 18K, 1/2 W	R33DC183J			
		R219, 220	Dep. Carbon, 15K, 1/2 W	R33DC153J			
W	RC20BF226K	R221	Composition, 22M, 10%, 1/2 W	RC20BF226K			

MISCELLANEOUS

Symbol	Description	Part No.
CR100,	Diodes, Type 1112	V-1112
CR102, 103	Bridge	V50160-13
L100	Coil, low pass	L50210-30
L101	Coil, 5.25MH	L50334-1
L102, 103	Coil, 20MH	L50334-2
Z100	Transformer, 19Kc	ZZ50210-34
Z101	Coil, 38Kc	ZZ50210-33

WAVEFORM DIAGRAM • MULTIPLEX SECTION

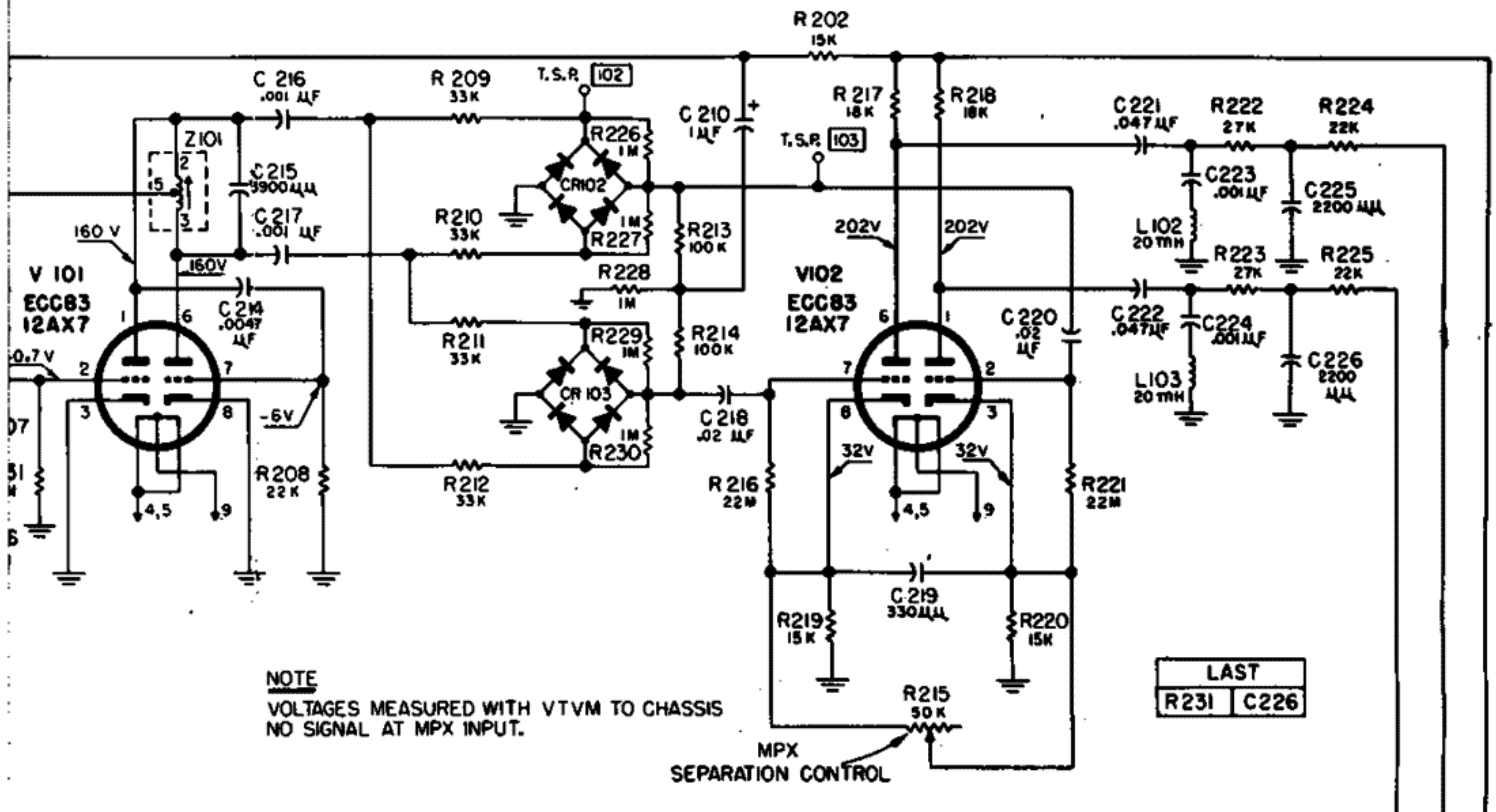

PARTS DESCRIPTION LIST

CAPACITORS

10% tolerance for all fixed capacitors, unless otherwise noted or marked GMV (guaranteed minimum value). All capacitors not marked uf are pF (uuf).

Symbol	Description	Part No.
C200	Ceramic, .01uf, +80 - 20%, 500V	C50089-7
C201	Ceramic, 680, 1000V	C50072-2
C203	Ceramic, 220, 1000V	C50183-3
C204	Polystyrene, 470, 5%, 500V	C50394-1
C205	Ceramic, 82, 1000V	C50070-1
C206	Ceramic, 1000, GMV, 500V	C50089-2
C207	Ceramic, 5000, +80 - 20%, 500V	C50089-6
C208, 209	Mica, 4700, 5%, 500V	C50332-5
C210	Electrolytic, 1uf, 350V	C50283-3
C211	Ceramic, 1000, GMV, 500V	C50089-2

C212	Ceramic, .05uf, +80 - 20%, 100V	C50073-2	R2
C214	Mylar, 4700, 400V	C50197-25	R2
C215	Mica, 3900, 5%, 500V	C50332-6	R2
C216, 217	Ceramic, 1000, GMV, 500V	C50089-2	R2
C218	Ceramic, .02uf, 20%, 500V	C50089-5	R2
C219	Ceramic, 330, 1000V	C50183-5	R2
C220	Ceramic, .02uf, 20%, 500V	C50089-5	R2
C221, 222	Mylar, .047uf, 250V	C50197-52	R2
C223, 224	Ceramic, 1000, 1000V	C50072-3	R2
C225, 226	Ceramic, 2200, 1000V	C50072-5	2

RESISTORS

In ohms, 5% tolerance, 1/8 W unless otherwise noted. K=Kilohms, M=Megohms.

Symbol	Description	Part No.
R200	Composition, 22M, 10%, 1/8 W	RC208F226K

SCHEMATIC DIAGRAM

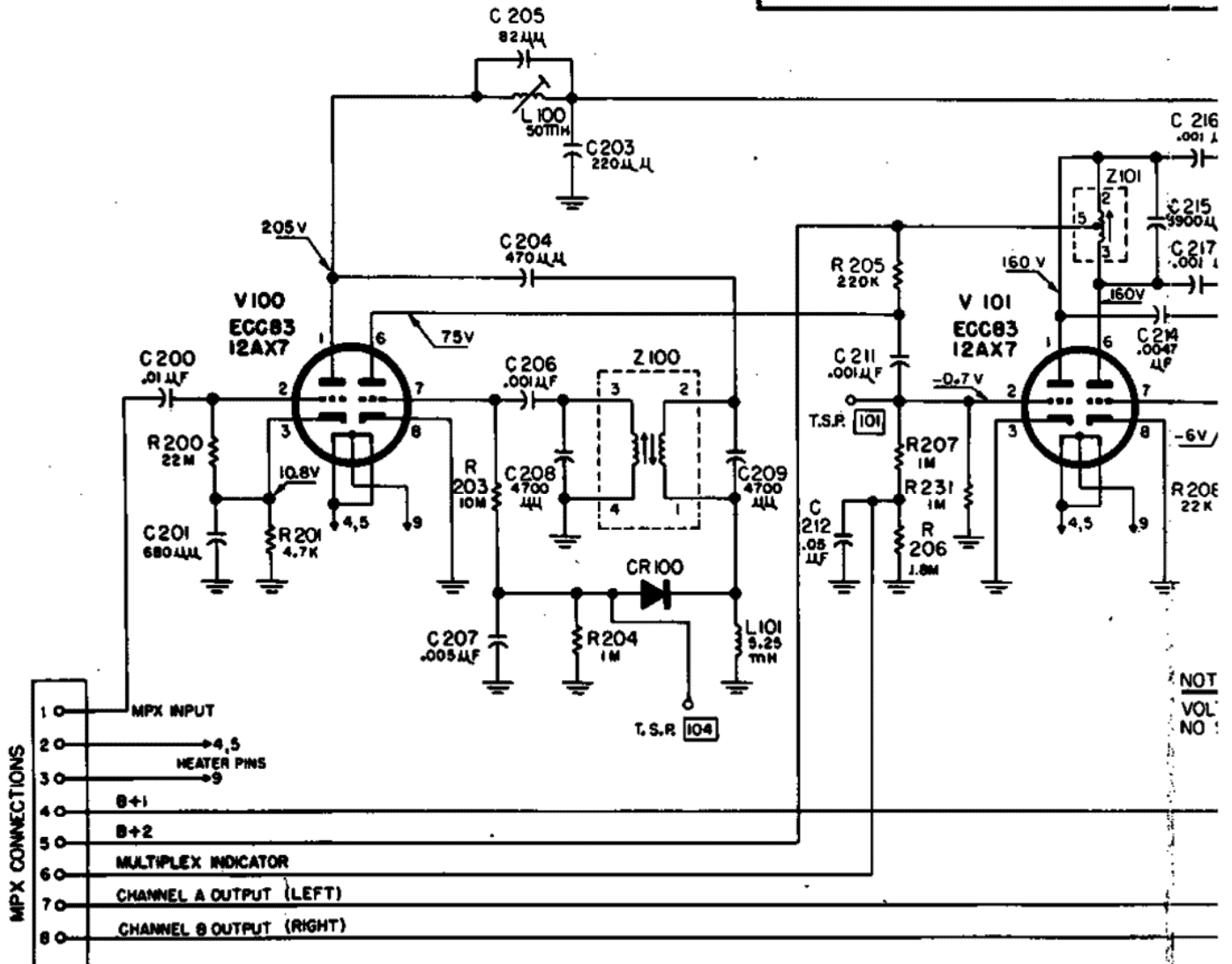

RECEIVER • SCHEMATIC

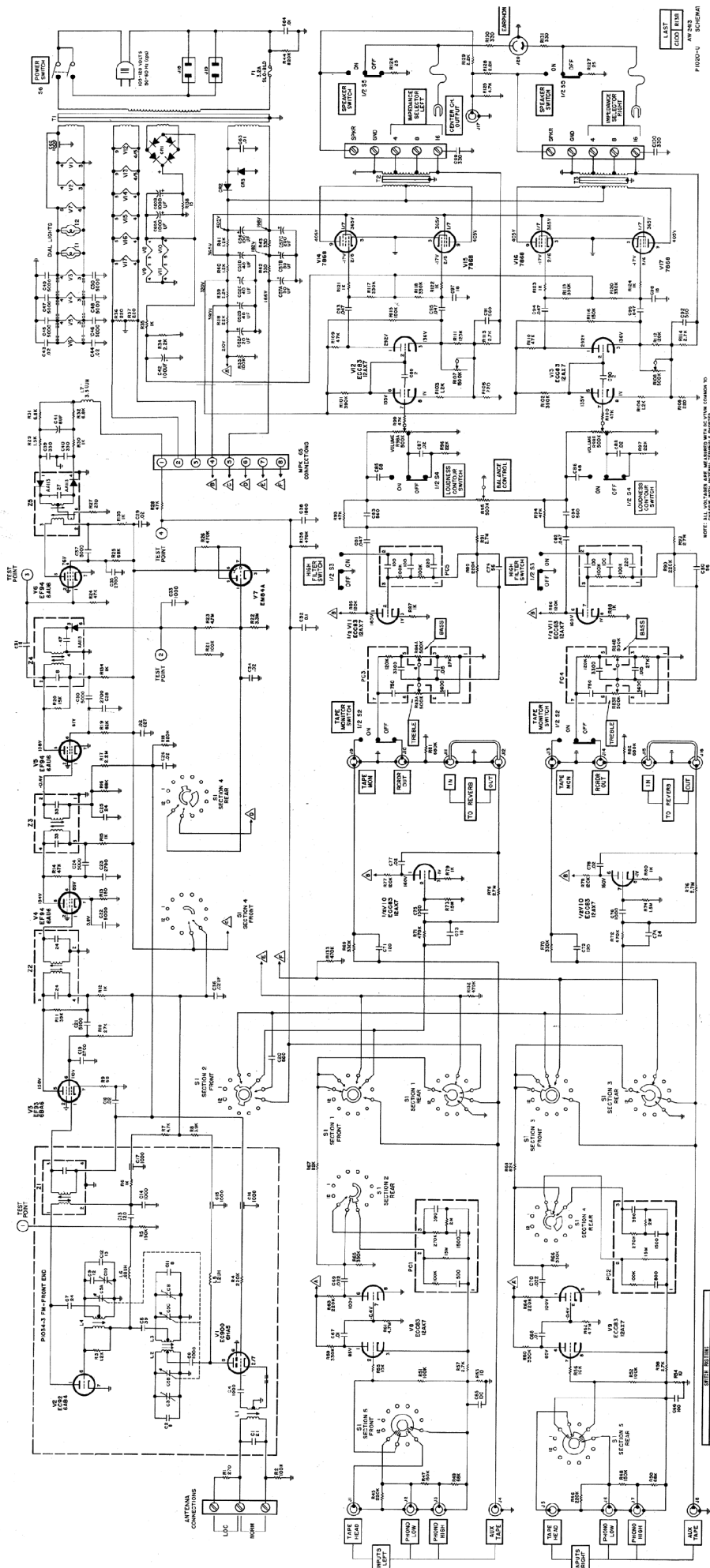

FIGURE 1
CROSS SECTION
SCHEMATIC

ITEM NO.	DESCRIPTION	QTY.
1	1/2" 10-32 X 1/2" SCREW	1
2	1/4" 10-32 X 1/2" SCREW	1
3	1/8" 10-32 X 1/2" SCREW	1
4	1/4" 10-32 X 1/2" SCREW	1
5	1/8" 10-32 X 1/2" SCREW	1
6	1/4" 10-32 X 1/2" SCREW	1
7	1/8" 10-32 X 1/2" SCREW	1
8	1/4" 10-32 X 1/2" SCREW	1
9	1/8" 10-32 X 1/2" SCREW	1
10	1/4" 10-32 X 1/2" SCREW	1
11	1/8" 10-32 X 1/2" SCREW	1
12	1/4" 10-32 X 1/2" SCREW	1
13	1/8" 10-32 X 1/2" SCREW	1
14	1/4" 10-32 X 1/2" SCREW	1
15	1/8" 10-32 X 1/2" SCREW	1
16	1/4" 10-32 X 1/2" SCREW	1
17	1/8" 10-32 X 1/2" SCREW	1
18	1/4" 10-32 X 1/2" SCREW	1
19	1/8" 10-32 X 1/2" SCREW	1
20	1/4" 10-32 X 1/2" SCREW	1
21	1/8" 10-32 X 1/2" SCREW	1
22	1/4" 10-32 X 1/2" SCREW	1
23	1/8" 10-32 X 1/2" SCREW	1
24	1/4" 10-32 X 1/2" SCREW	1
25	1/8" 10-32 X 1/2" SCREW	1
26	1/4" 10-32 X 1/2" SCREW	1
27	1/8" 10-32 X 1/2" SCREW	1
28	1/4" 10-32 X 1/2" SCREW	1
29	1/8" 10-32 X 1/2" SCREW	1
30	1/4" 10-32 X 1/2" SCREW	1
31	1/8" 10-32 X 1/2" SCREW	1
32	1/4" 10-32 X 1/2" SCREW	1
33	1/8" 10-32 X 1/2" SCREW	1
34	1/4" 10-32 X 1/2" SCREW	1
35	1/8" 10-32 X 1/2" SCREW	1
36	1/4" 10-32 X 1/2" SCREW	1
37	1/8" 10-32 X 1/2" SCREW	1
38	1/4" 10-32 X 1/2" SCREW	1
39	1/8" 10-32 X 1/2" SCREW	1
40	1/4" 10-32 X 1/2" SCREW	1
41	1/8" 10-32 X 1/2" SCREW	1
42	1/4" 10-32 X 1/2" SCREW	1
43	1/8" 10-32 X 1/2" SCREW	1
44	1/4" 10-32 X 1/2" SCREW	1
45	1/8" 10-32 X 1/2" SCREW	1
46	1/4" 10-32 X 1/2" SCREW	1
47	1/8" 10-32 X 1/2" SCREW	1
48	1/4" 10-32 X 1/2" SCREW	1
49	1/8" 10-32 X 1/2" SCREW	1
50	1/4" 10-32 X 1/2" SCREW	1

ALL DIMENSIONS ARE IN INCHES UNLESS OTHERWISE SPECIFIED.